

Section: ENGINE
CRANKCASE

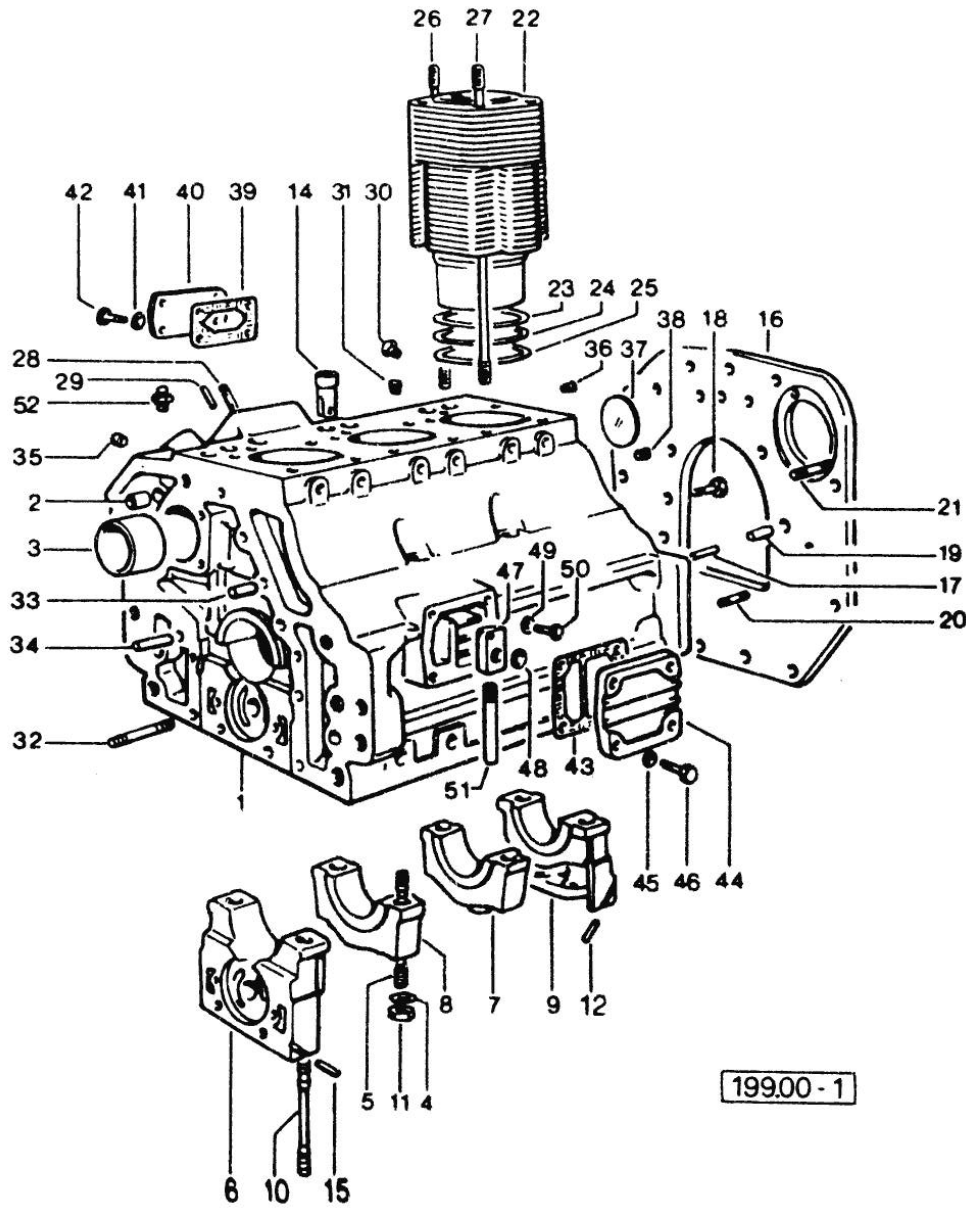
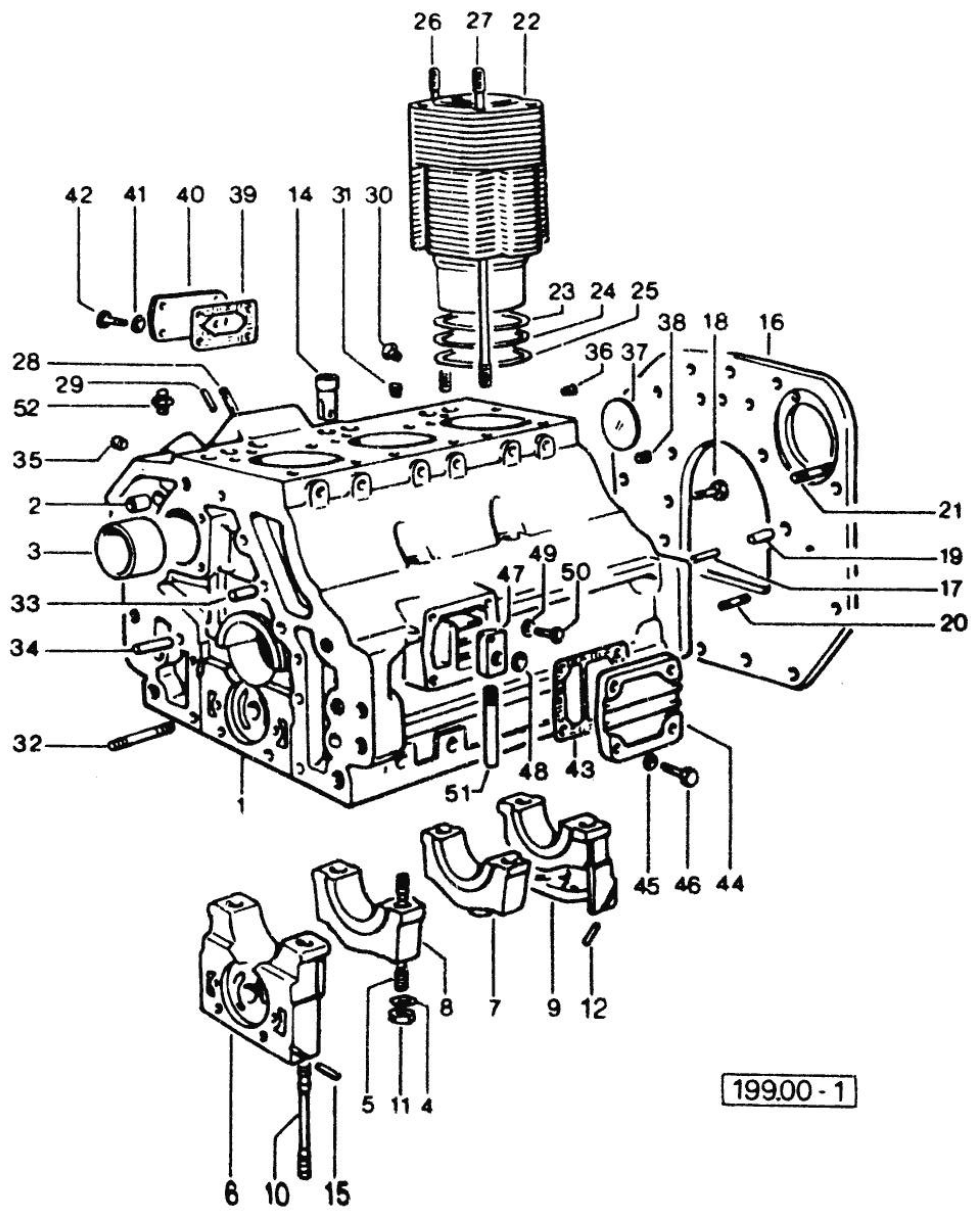

Fig.	P/n	QTY	Name
------	-----	-----	------

Notes:
 [R 653]

0	0.054.0050.6	1	gasket set
1	0.054.1110.4/30	1	crankcase
2	2.1559.111.0	2	bushing 12x14x10
3	0.037.1155.0	1	bushing
4	2.1599.144.0	8	shoulder
5	0.029.1117.0	4	stud bolt
6	0.054.1112.0	1	support
7	0.037.1114.0	1	support
8	0.029.1113.0	1	support
9	0.029.1116.0	1	support
10	0.021.1157.0	4	stud bolt
11	2.1019.026.1	8	special nut m 12 p.1.5
12	0.029.1154.0	4	gasket
14	0.044.1156.0	6	special bushing
15	0.029.1154.0	4	gasket
16	0.045.1152.0/10	1	plate
17	2.1653.708.0	2	pin 8x18
18	2.0112.511.2	11	screw m 14 p.2 x 30
19	2.1652.911.0	2	cylindrical plug 12x25
20	2.0432.153.2	2	stud bolt
21	2.0432.255.2	2	stud bolt m 12 p.1.75-1.25x25
22	0.044.1120.0/10	3	engine cylinder
23	2.1589.052.0	3	shoulder ring 115x123x0.2
24	2.1589.051.0	3	shoulder ring 116x123x0.1
25	2.1569.076.0	3	gasket 116x123x0.5
26	0.041.1123.0	3	stud bolt m 10
27	0.039.1122.0	12	stud bolt m 12 p.1.5x310
28	2.0432.003.1	4	stud bolt m 8 p.1.25 / p.1 x 20
29	2.1653.306.0	1	pin
30	0.041.1151.3/10	3	sprayer nozzle
31	2.3130.001.1	2	plug 1/8" gas
32	2.0432.025.1	2	stud bolt m 8 p 1.25-1x100
33	2.1653.711.0	1	pin
34	2.1699.114.0	1	pin 8x55
35	2.3139.001.0	3	plug m 12 p.1.75
36	2.3130.002.1	1	plug 1/4" gas
37	2.3170.022.1	1	expansion plug 60
38	2.3130.003.1	2	plug 3/8" gas
39	0.044.1151.0	1	gasket
40	0.044.1150.0	1	cover
41	2.1310.004.2	4	flat washer 8.4x17

CRANKCASE



199.00 - 1

Fig.	P/n	QTY	Name
42	2.0112.204.2	4	screw m 8 p.1.25x14
43	0.044.1153.0/10	1	gasket
44	0.044.1154.0	1	cover
45	2.1474.009.2	4	spring washer 8
46	2.0112.209.2	4	screw m 8 p 1.25 x 25
47	0.044.1155.2/20	1	cover
48	0.045.1150.0	1	oil seal
49	2.1474.009.2	1	spring washer 8
50	2.0312.206.2	1	screw m 8 p 1.25 x 20
51	0.044.1152.0	1	tube
52	0.054.1152.0	1	pipe fitting

Section: ENGINE

TIMING CASE

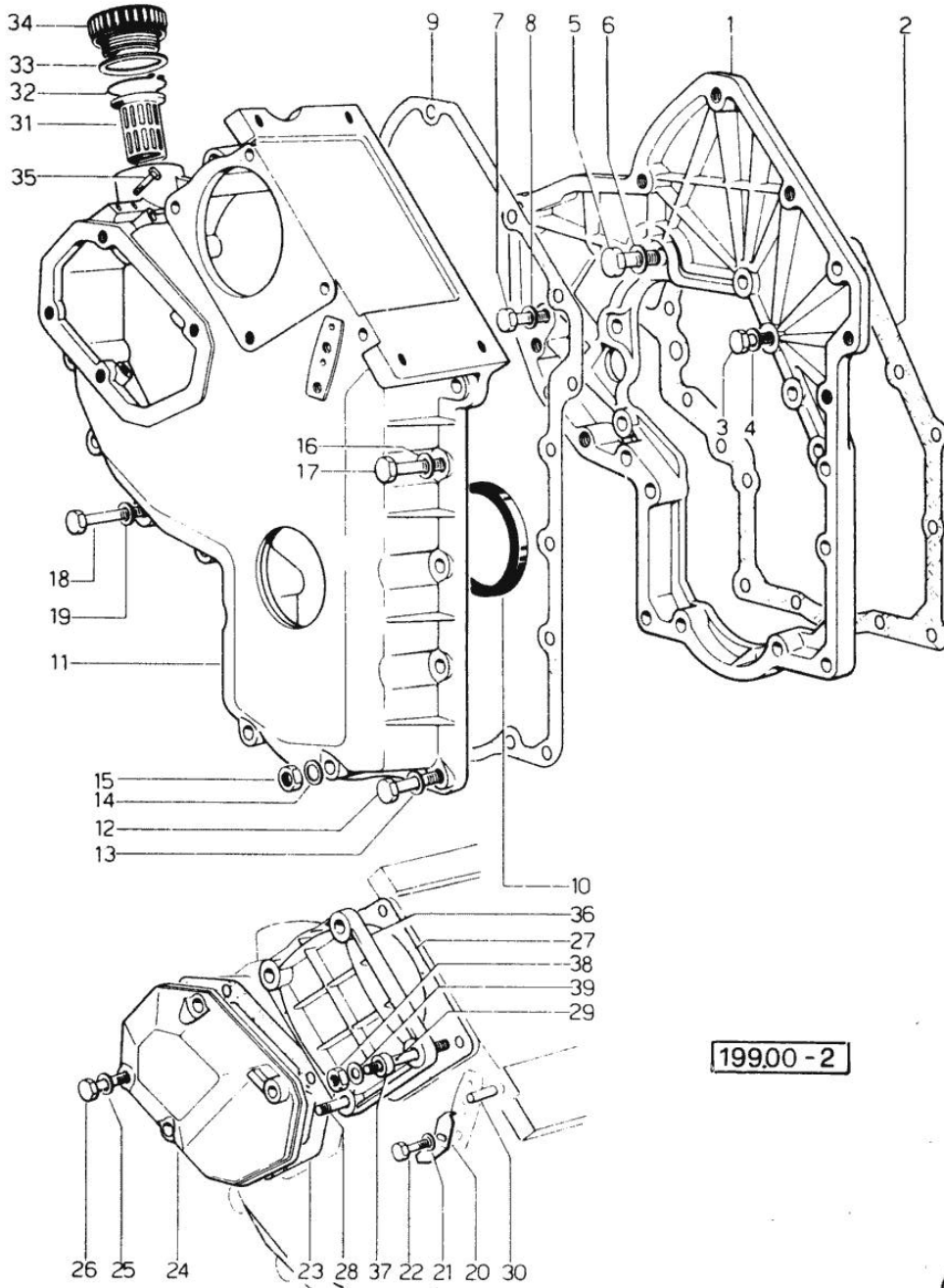

Fig.	P/n	QTY	Name
------	-----	-----	------

Notes:
[R 653]

1	0.048.1131.0	1	flange
2	0.041.1153.0	1	gasket
3	2.0112.209.2	5	screw m 8 p 1.25 x 25
4	2.1474.009.2	5	spring washer 8
5	2.0119.034.1	1	screw m 14 p.2x20
6	2.1560.010.0	1	gasket 14.2 x 20
7	2.0112.207.2	1	screw m 8 p 1.25 x 20
8	2.1474.009.2	1	spring washer 8
9	0.041.1152.0	1	gasket
10	2.1519.010.0	1	special oil seal 58x80x10
11	0.048.1132.0/10	1	guard
12	2.0112.217.2	5	screw m 8 p.1.25 x 45
13	2.1474.009.2	5	spring washer 8
14	2.1560.003.0	2	copper gasket 8.2 x 12
15	2.1011.405.2	2	nut m 8 p.1
16	2.1474.009.2	2	spring washer 8
17	2.0112.211.2	2	screw m 8 p.1.25 x 30
18	2.0112.222.2	4	screw m 8 p.1.25x65
19	2.1474.009.2	4	spring washer 8
20	0.041.1158.0	1	index
21	2.1310.004.2	1	flat washer 8.4x17
22	2.0112.204.2	1	screw m 8 p.1.25x14
23	0.048.1152.0	1	gasket
24	0.048.1150.0/20	1	cover
25	2.1560.005.0	4	copper gasket 10.2 x 14
26	2.0112.315.2	3	screw m 10 p.1.5 x 40
27	0.041.1154.0	1	gasket
28	2.0432.015.2	1	stud bolt m 8 p.1.25-1x50
29	2.0432.028.1	3	stud bolt m 8 p.1.25-1x130
30	2.1653.717.0	1	pin 8 x 40
31	0.041.1159.0/10	1	filter
32	2.1411.012.1	1	circlip 30
33	2.1569.072.0	1	gasket 32 x 39.5 x 2
34	0.041.1135.0	1	plug
35	2.0119.081.2	2	screw
36	0.037.1151.0	1	cover
36	0.037.1151.0/10	1	cover 2401 <- >- 2402
37	2.1579.191.0	4	spacer 8.5 x 18 x 20
38	2.1011.505.2	4	nut m 8 p.1

TIMING CASE

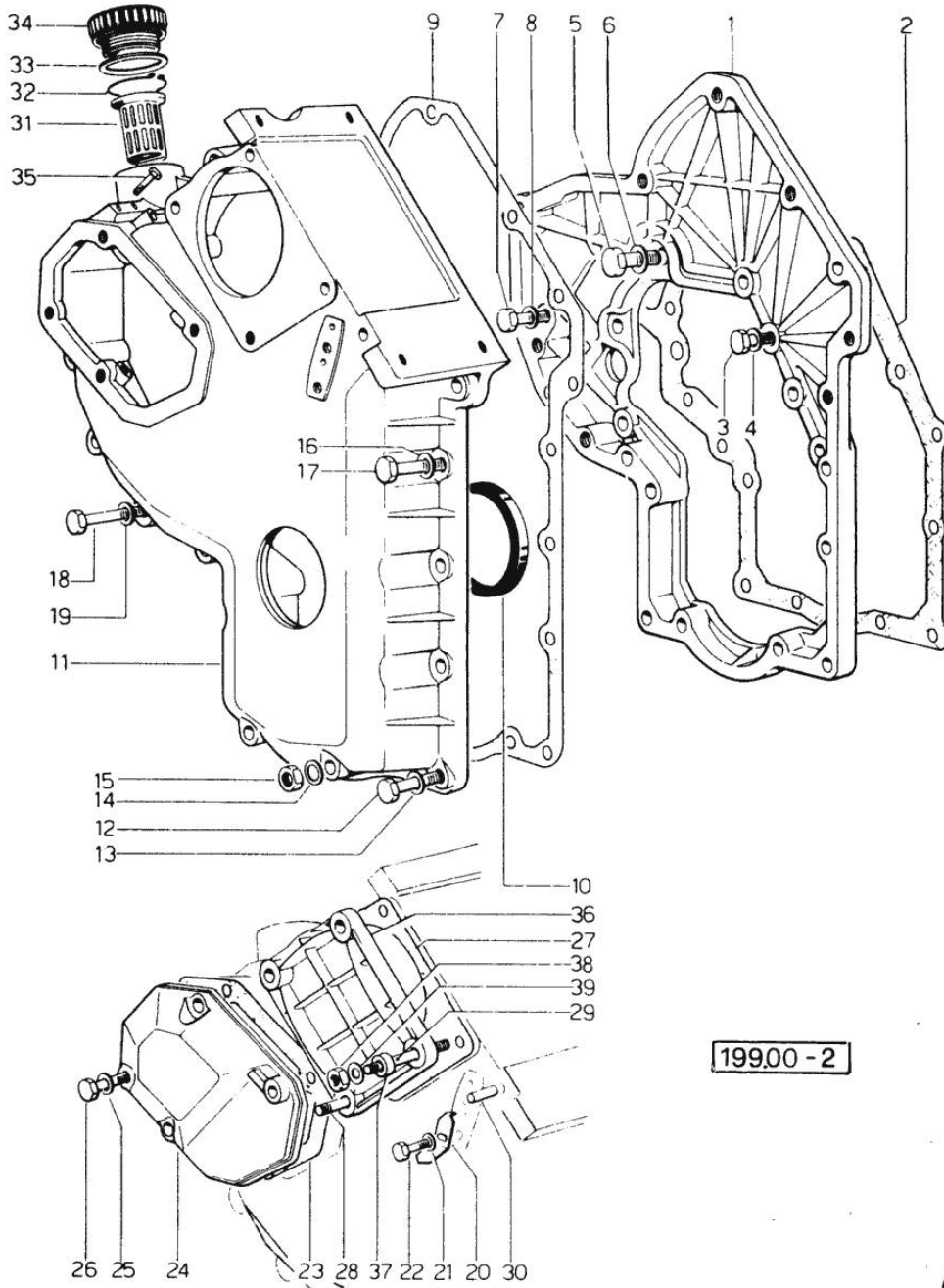

Fig.	P/n	QTY	Name
39	2.1310.004.2	4	flat washer 8.4x17

Section: ENGINE

CRANKSHAFT

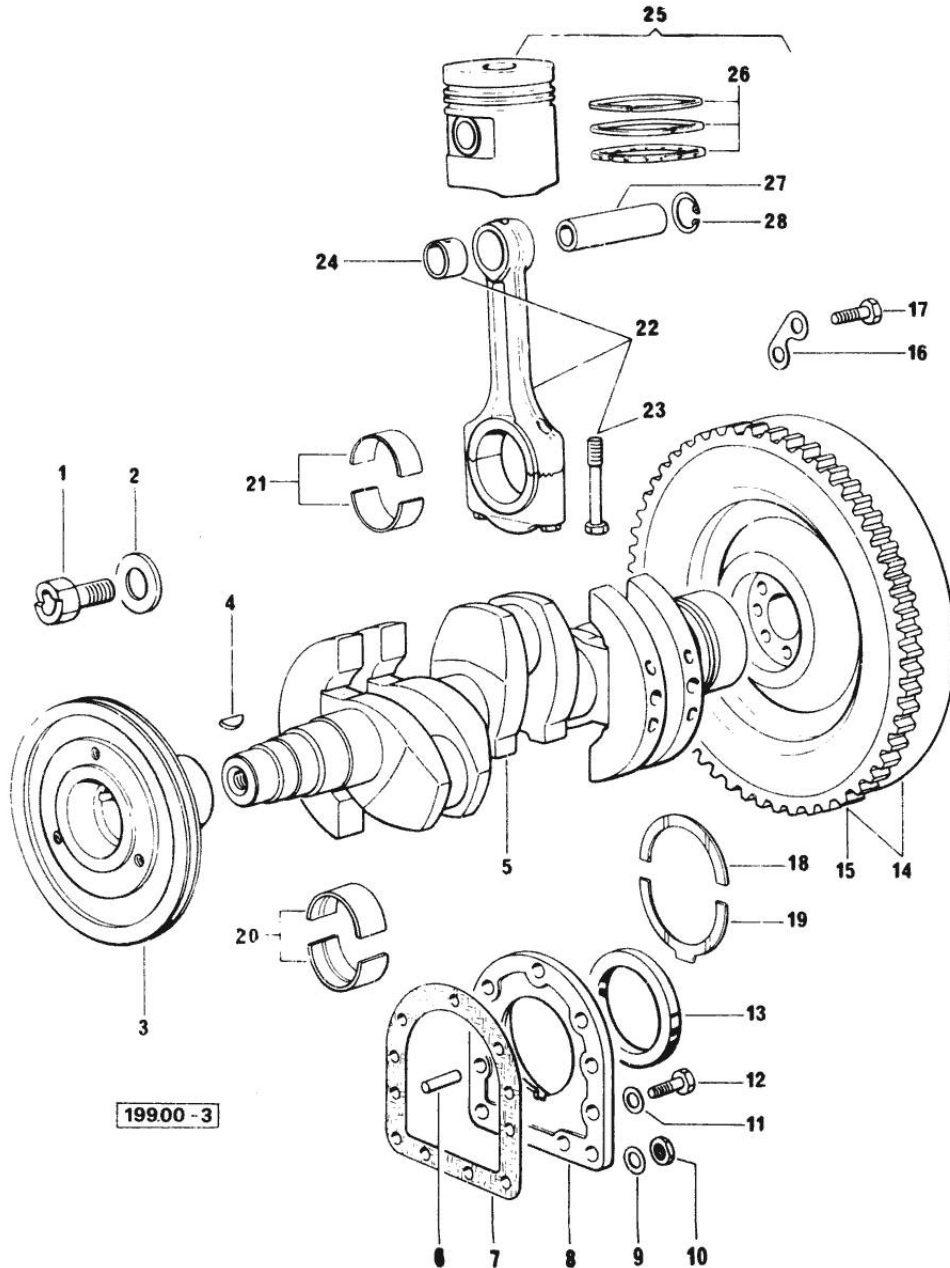

Fig.	P/n	QTY	Name
Notes:			
[R 653]			
1	2.0129.032.2	1	screw m 24 p.2x45
2	0.001.6020.0	1	shoulder
3	0.054.1250.0	1	pulley 2401 <-
3	0.062.1250.0	3	pulley -> 2402
4	2.1799.002.0	1	stick 10x13 2401 <-
4	2.1799.026.0	1	key 10x10 -> 2402
5	0.054.1210.4	1	crankshaft
6	2.1652.915.0	2	cylindrical plug 12x35
7	0.029.1250.0	1	gasket
8	0.029.1240.0	1	flange 2401 <-
8	0.045.1240.0	1	flange -> 2402
9	2.1560.006.0	2	gasket 10.2 x 16
10	2.1011.421.2	2	nut m 10 p.1.25
11	2.1474.010.2	7	washer 10
12	2.0112.309.2	7	screw m 10 p.1.5 x 25
13	2.1529.045.0	1	oil seal
14	0.045.1251.3	1	flywheel
15	0.036.1242.0	1	crown wheel Z = 126, mm 15
16	2.1379.006.0	3	lock-tab 15x15x36,5
17	2.0122.515.2	6	screw m 14 p.1.5x40
18	0.001.4544.0	2	shoulder ring + mm 0.05
18	0.001.4545.0	2	shoulder ring + mm 0.10
18	0.001.4546.0	2	shoulder ring + mm 0.15
18	0.042.1218.0	2	shoulder ring STANDARD
19	0.001.4547.0	2	shoulder ring + mm 0.05
19	0.001.4548.0	2	shoulder ring + mm 0.10
19	0.001.4549.0	2	shoulder ring + mm 0.15
19	0.042.1219.0	2	shoulder ring STANDARD
20	0.029.0066.0	8	main half bushing - mm 1.00
20	0.029.1215.0/10	8	main half bushing 2401 <-
20	0.029.1215.7	8	main half bushing - mm 0.25 -> 2402
20	0.029.1215.8	8	main half bushing - mm 0.50
20	0.029.1215.9	8	main half bushing - mm 0.75

CRANKSHAFT

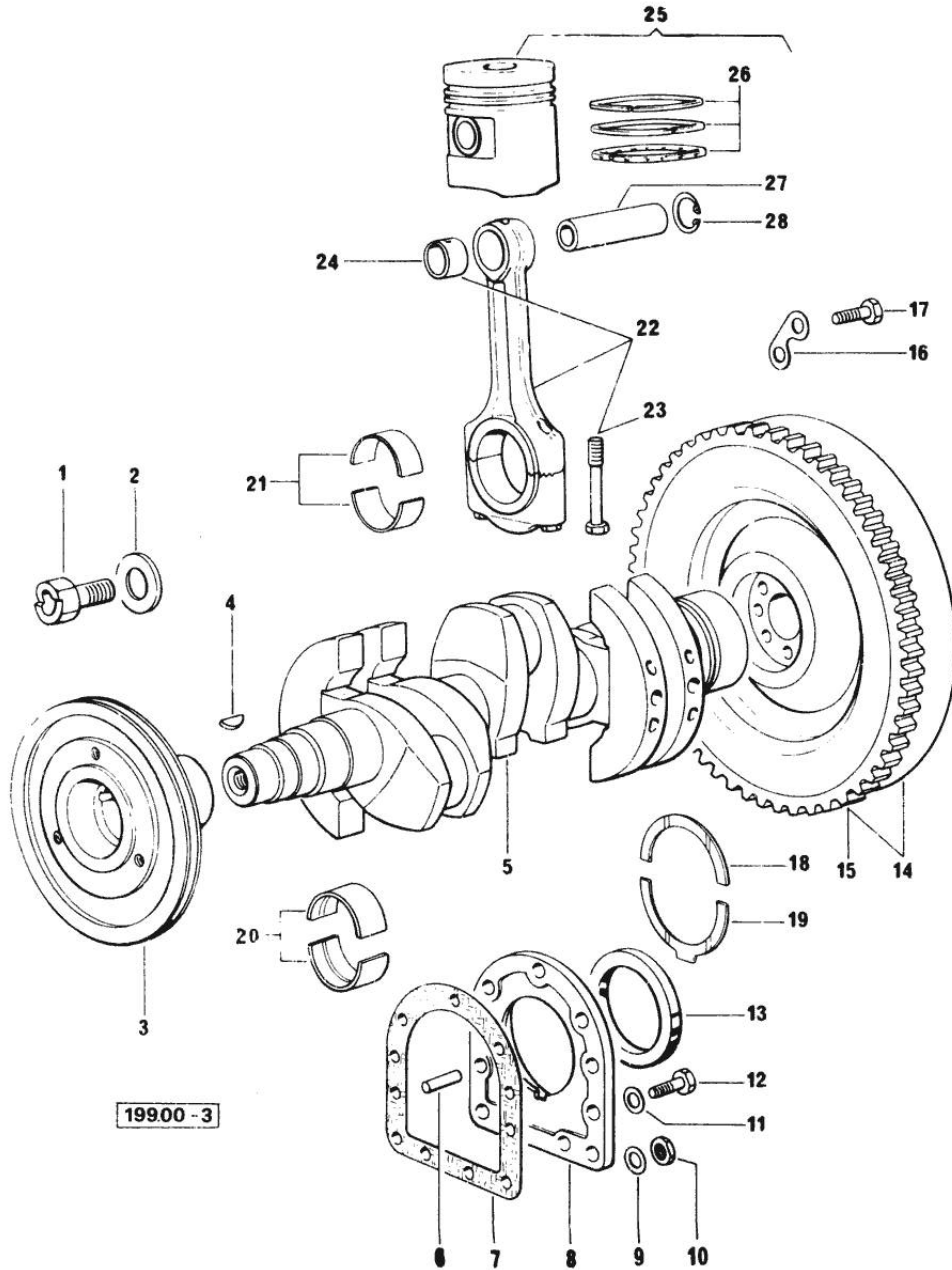
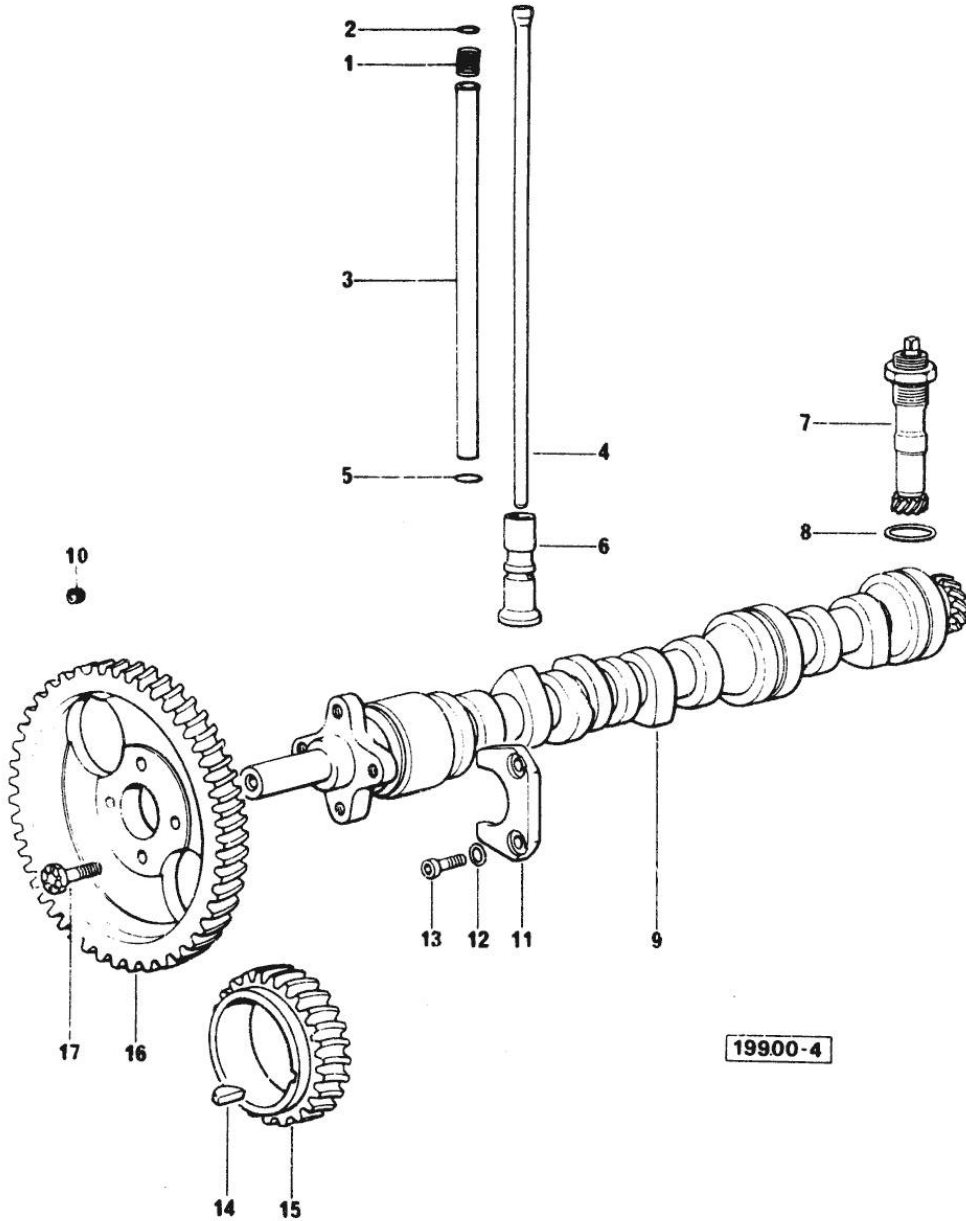

Fig.	P/n	QTY	Name
21	0.039.0068.0	6	con.rod half bushing - mm 1.016
21	0.039.1225.0	6	con.rod half bushing
21	0.039.1225.7	6	con.rod half bushing -mm 0.254
21	0.039.1225.8	6	con.rod half bushing -mm 0.508
21	0.039.1225.9	6	con.rod half bushing -mm 0.762
22	0.052.1220.3	3	engine connecting rod
23	0.039.1250.0	6	screw m 14 p.1.5x63
24	0.002.4168.0	3	bearing
25	0.046.0060.6	3	complete piston
25	0.046.0061.6	3	complete piston + mm 0.5
25	0.046.0062.6	3	complete piston + mm 1.0
26	0.054.0052.6	3	piston ring set
26	0.054.0053.6	3	piston ring set + mm 0.5
26	0.054.0054.6	3	piston ring set + mm 1.0
27	0.002.4167.0	3	piston pin -> 2402
27	0.038.1236.0	3	piston pin 2401 <-
28	2.1411.014.1	6	circlip 35

Section: ENGINE

CAMSHAFT



19900-4

Fig.	P/n	QTY	Name
------	-----	-----	------

Notes:
[R 653]

1	2.4019.162.1/20	6	spring 17.2x46x1.8
2	2.1539.022.0	6	special oil seal 12.37x2.62
3	0.041.1332.0	6	sleeve
4	0.041.1331.3	6	rod
5	2.1539.020.0	6	special oil seal 13.95x2.62
6	0.044.1330.0/10	6	tappets
7	0.041.1355.3	1	transmission
8	2.1560.013.0	1	gasket 18.2x22
9	0.054.1310.0	1	camshaft
10	2.3130.001.1	1	plug 1/8" gas
11	0.027.1314.0	1	flange
12	2.1470.004.2	2	lock washer 8
13	2.0112.207.2	2	screw m 8 p 1.25 x 20
14	2.1720.010.0	1	key 5x9
15	0.040.1320.0	1	gear z = 33
16	0.041.1321.0	1	gear z = 66
			2401 <-
16	0.062.1321.0	1	gear z=66
			-> 2402
17	2.0139.005.1	4	screw m 10 p.1 x 25

Buy Now



Our support email:

ebooklibonline@outlook.com