

Section: ENGINE
CRANKCASE

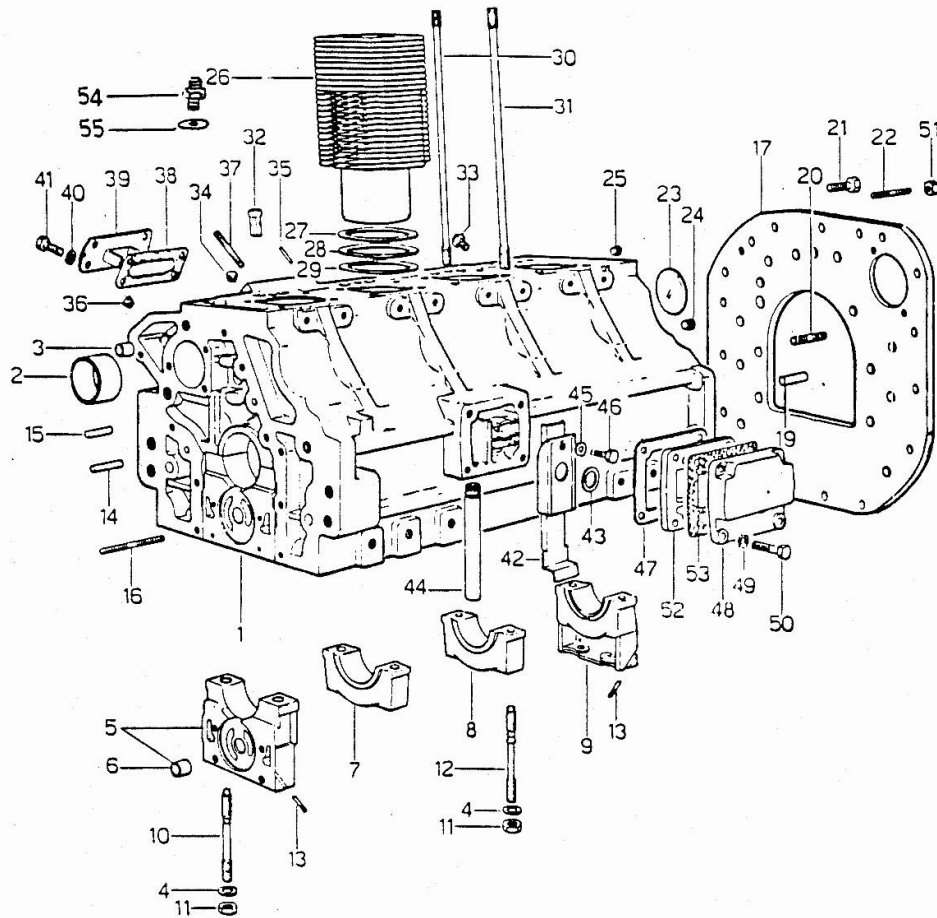

Fig.	P/n	QTY	Name
------	-----	-----	------

Notes:

- FOR TYPES WITHOUT H-M-L (POWERSHIFT) [R 714 V]

0	0.063.0050.6		gasket set - FOR ENGINE MOUNTING
1	0.044.1110.6/10	1	crankcase - UP TO ENGINE NO. 6125 /n UP TO ENGINE NO. 4433 ORDER ALSO NO.1 FLANGE 0.045.1240.0 NO.1 SCREW 2.0112.309.2 NO.1 WASHER 2.1474.010.2
1	0.045.1110.4/20	1	crankcase - FROM ENGINE NO.6126
2	0.037.1155.0	1	bushing
3	2.1559.111.0/10	2	special bushing 11.5x14.1x10
4	2.1599.144.7	10	shoulder ring 12.5x23x4
5	0.036.1112.3	1	support
6	2.1559.090.0/10	1	bushing 14.24x19.06x27
7	0.037.1114.0	1	support
8	0.029.1113.0	2	support
9	0.029.1116.0	1	support
10	0.021.1157.0	4	stud bolt
11	2.1019.026.7	10	special nut m 12 p.1.5
12	0.029.1117.0	6	stud bolt
13	0.029.1154.0	4	gasket
14	2.1699.114.0	1	pin 8x55
15	2.1653.711.0	1	pin
16	2.0432.025.1	2	stud bolt m 8 p 1.25-1x100
17	0.054.1130.0/10	1	flange
19	2.1652.911.0	2	cylindrical plug 12x25
20	2.0432.153.1	2	stud bolt m 10 p.1.5 / p.1.25 x 20
21	2.0112.511.1	11	screw m 14 p.2 x 30
22	2.0432.257.1	3	stud bolt m 12 p.1.75 - 1.25 x 30
23	2.3170.022.1	1	expansion plug 60
24	2.3130.003.1	2	plug 3/8" gas
25	2.3130.002.1	1	plug 1/4" gas
26	0.063.1120.0	4	engine cylinder
27	2.1589.052.0	8	shoulder ring 115x123x0.2
28	2.1589.051.0	4	shoulder ring 116x123x0.1
29	2.1569.076.0	4	gasket 116x123x0.5
30	0.041.1123.0/10	4	stud bolt
31	0.039.1122.0	16	stud bolt m 12 p.1.5x310
32	0.044.1156.0	8	special bushing
33	0.071.1151.3	4	valve
34	2.3130.001.1	3	plug 1/8" gas
35	2.1652.507.0	2	pin 6x16

Section: ENGINE
CRANKCASE

Fig.	P/n	QTY	Name
36	2.3139.001.1	5	plug
37	2.0432.003.1	4	stud bolt m 8 p.1.25 / p.1 x 20
38	0.044.1151.0	1	gasket
39	0.044.1164.2/10	1	small cover
40	2.1310.004.2	4	flat washer 8.4x17
41	2.0112.204.2	4	screw m 8 p.1.25x14
42	0.044.1162.2	1	small guard
			- UP TO ENGINE NO. 6125
42	0.071.1155.2	1	small guard
			- FROM ENGINE NO.6126
43	0.071.1156.0	1	special oil seal
44	0.044.1152.0/10	1	tube
45	2.1474.009.1	1	spring washer 8
46	2.0312.206.2	1	screw m 8 p 1.25 x 20
47	0.044.1153.0/10	1	gasket
48	0.071.1154.0	1	small cover
			- UP TO ENGINE NO. 6125 ORDER ALSO NO. 1
			COVER 071.1153.0 NO. 1 GASKET 044.1153.0/10
49	2.1310.004.2	1	flat washer 8.4x17
			- UP TO ENGINE NO. 6125
49	2.1474.009.1	4	spring washer 8
50	2.0112.204.2	1	screw m 8 p.1.25x14
			- UP TO ENGINE NO. 6125
50	2.0112.211.2	4	screw m 8 p.1.25 x 30
51	2.1011.207.2	2	nut m 12 p.1.5
52	0.071.1153.0	1	small cover
			- UP TO ENGINE NO. 6125 ORDER ALSO NO. 1
			COVER 071.1154.0 NO. 1 GASKET 044.1153.0/10
53	0.044.1153.0/10	1	gasket
			- FROM ENGINE NO.6126
53	0.044.1161.0	1	gasket
			- UP TO ENGINE NO. 6125
54	0.054.1150.0	1	pipe fitting
55	2.1560.006.0	1	gasket 10.2 x 16

Section: ENGINE

TIMING CASE

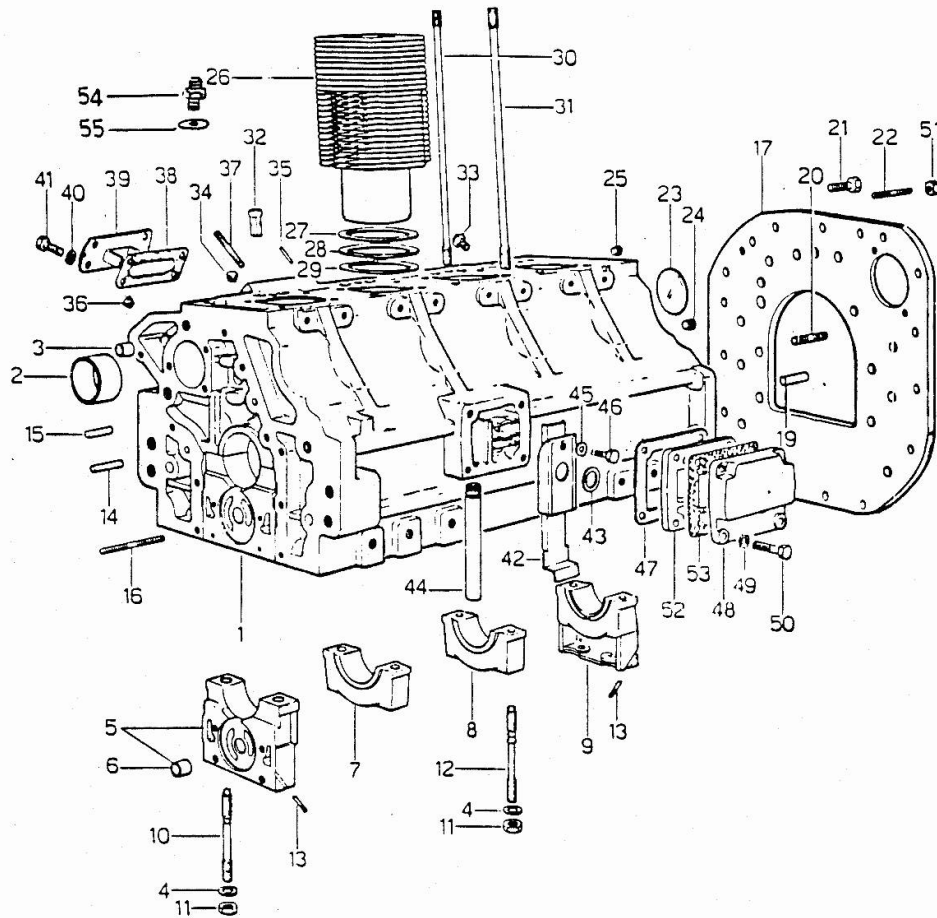
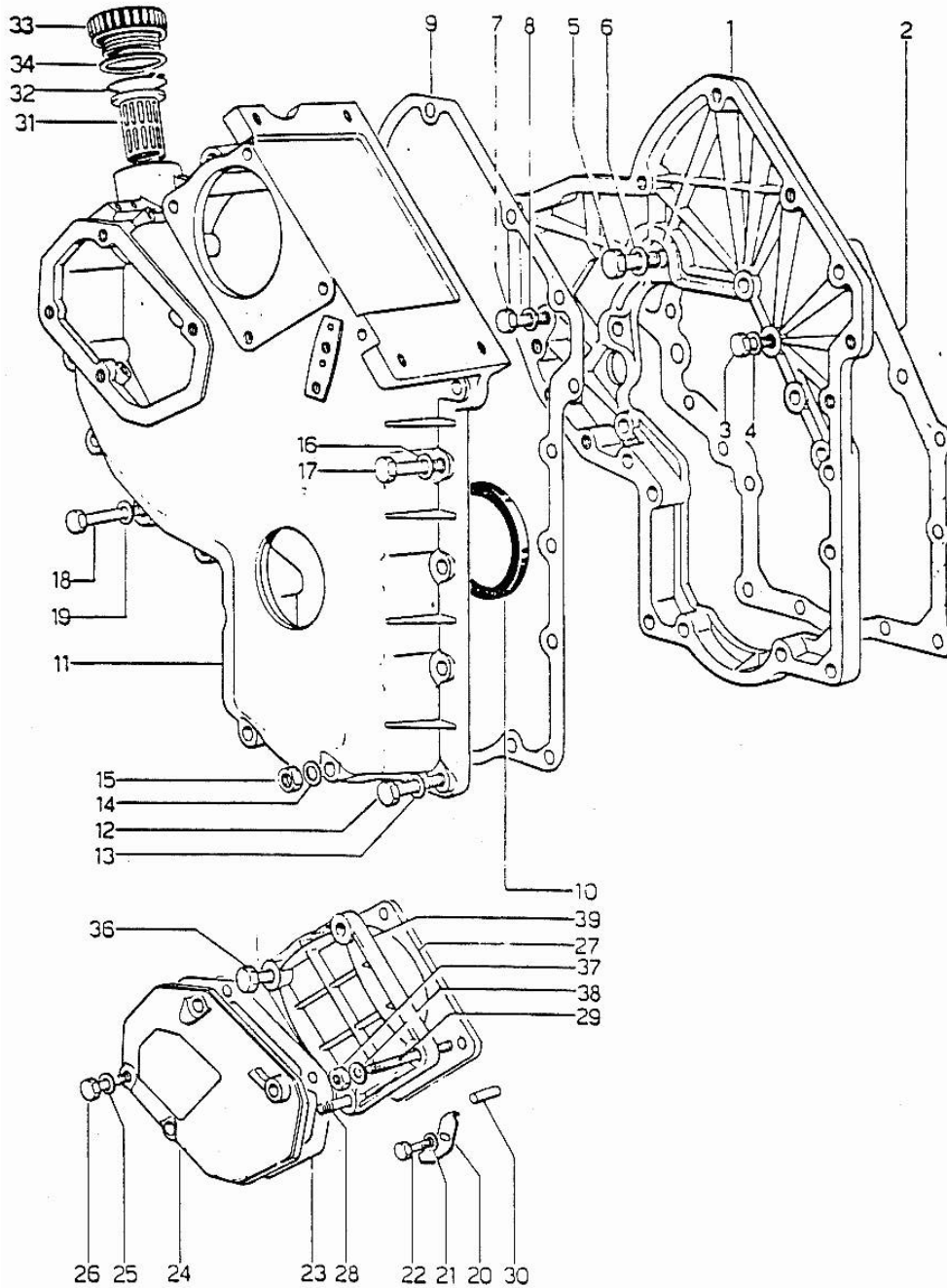

Fig.	P/n	QTY	Name
------	-----	-----	------

Notes:

[R 714 V]

1	0.048.1131.0	1	flange
2	0.041.1153.0	1	gasket
3	2.0112.209.2	2	screw m 8 p 1.25 x 25
3	2.0112.211.2	3	screw m 8 p.1.25 x 30
4	2.1474.009.1	5	spring washer 8
5	2.0119.034.1	1	screw m 14 p.2x20
6	2.1560.010.0	1	gasket 14.2 x 20
7	2.0122.207.2	1	screw m 8 p.1x20
8	2.1474.009.1	1	spring washer 8
9	0.041.1152.0	1	gasket
10	2.1519.010.0	1	special oil seal 58x80x10
11	0.048.1132.0/40	1	guard
12	2.0112.217.2	5	screw m 8 p.1.25 x 45
13	2.1474.009.1	5	spring washer 8
14	2.1560.003.0	2	copper gasket 8.2 x 12
15	2.1011.405.2	1	nut m 8 p.1
16	2.1474.009.1	2	spring washer 8
17	2.0112.211.2	2	screw m 8 p.1.25 x 30
18	2.0112.222.2	4	screw m 8 p.1.25x65
19	2.1474.009.1	4	spring washer 8
20	0.041.1158.0	1	index
21	2.1310.004.2	1	flat washer 8.4x17
22	2.0112.204.2	1	screw m 8 p.1.25x14
23	0.048.1151.0/10	1	gasket
24	0.048.1150.0/20	1	cover
25	2.1560.006.0	4	gasket 10.2 x 16
26	2.0112.315.2	4	screw m 10 p.1.5 x 40
27	0.041.1154.0	1	gasket
28	2.0432.015.1	1	stud bolt m 8 p 1.25 - m 8 p. 1x50
29	2.0432.028.1	2	stud bolt m 8 p.1.25-1x130
30	2.1653.717.0	1	pin 8 x 40
31	0.041.1159.0/10	1	filter
32	2.1411.012.1	1	circlip 30
33	0.041.1135.4	1	plug 1" gas
34	2.1569.072.0	1	gasket 32 x 39.5 x 2
36	2.0112.235.2	1	screw m 8 p.1.25 x 130
37	2.1011.505.2	3	nut m 8 p.1
38	2.1310.004.2	4	flat washer 8.4x17
39	0.037.1151.0/10	1	cover

Section: ENGINE
CRANKSHAFT

Fig.	P/n	QTY	Name
------	-----	-----	------

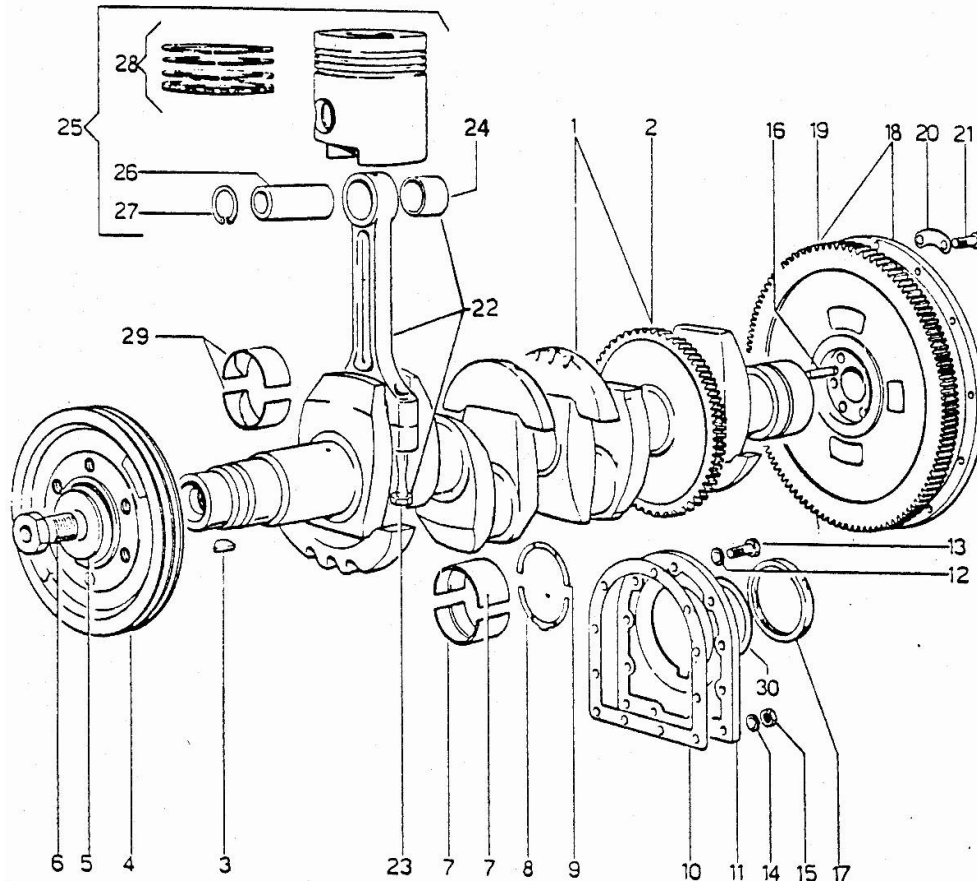
Notes:
[R 714 V]

1	0.044.1267.4/30	1	crankshaft - UP TO ENGINE NO. 5544 ORDER ALSO: NO. 1 WRENCH 2.1799.026.0
1	2.1630.611.0	1	roll pin 6 x 24
2	0.044.1265.0/20	1	gear
3	2.1799.002.0	1	stick 10x13 - UP TO ENGINE NO. 5544
3	2.1799.026.0	1	key 10x10 - FROM ENGINE NO. 5545
4	0.062.1250.0	1	pulley
5	0.001.6020.0	1	shoulder
6	2.0129.032.2	1	screw m 24 p.2x45
7	0.073.1215.0	10	main half bushing STANDARD
7	0.073.1215.7		main half bushing - mm 0.25
7	0.073.1215.8		main half bushing - mm 0.50
7	0.073.1215.9		main half bushing - mm 0.75
8	0.001.4547.0		shoulder ring + mm 0.05
8	0.001.4548.0		shoulder ring + mm 0.10
8	0.001.4549.0		shoulder ring + mm 0.15
8	0.042.1219.0	2	shoulder ring STANDARD
9	0.001.4544.0		shoulder ring + mm 0.05
9	0.001.4545.0		shoulder ring + mm 0.10
9	0.001.4546.0		shoulder ring + mm 0.15
9	0.042.1218.0	2	shoulder ring STANDARD
10	0.029.1250.0/10	1	gasket
11	0.045.1240.0	1	flange
12	2.1474.010.1	9	spring washer 10
13	2.0112.309.2	9	screw m 10 p.1.5 x 25
14	2.1560.006.0	2	gasket 10.2 x 16
15	2.1011.421.2	2	nut m 10 p.1.25
16	2.1652.915.0	2	cylindrical plug 12x35
17	2.1519.009.0/10	1	special oil seal
18	0.054.1241.3/20	1	flywheel
19	0.036.1242.0	1	crown wheel Z = 126, mm 15
20	2.1379.006.0	3	lock-tab 15x15x36,5
21	2.0122.515.7	6	screw
22	0.052.1220.3/10	4	engine connecting rod
23	0.039.1250.0	8	screw m 14 p.1.5x63
24	0.002.4168.0	4	bearing
25	0.072.0060.6	4	complete piston STANDARD
25	0.072.0061.6		complete piston + mm 0.50

Section: ENGINE
CRANKSHAFT

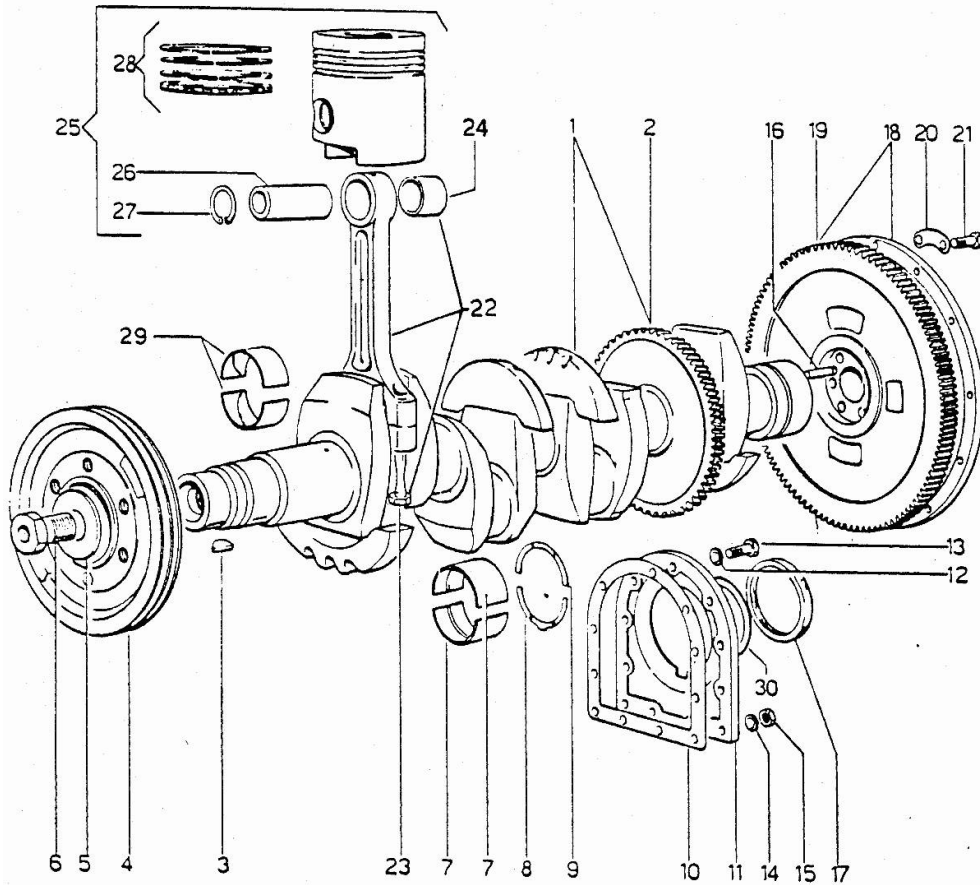

Fig.	P/n	QTY	Name
25	0.072.0062.6		complete piston + mm 1.0
26	0.002.4167.0	4	piston pin
27	2.1411.014.1	8	circlip 35
28	0.072.0052.6	4	piston ring set STANDARD
28	0.072.0053.6		piston ring set + mm 0.50
28	0.072.0054.6		piston ring set + mm 1.0
29	0.062.1225.0	8	con.rod half bushing STANDARD
29	0.062.1225.7		con.rod half bushing - mm 0.25
29	0.062.1225.8		con.rod half bushing - mm 0.50
29	0.062.1225.9		con.rod half bushing - mm 0.75
30	2.1599.404.0	1	shoulder ring

CRANKSHAFT - HARMONIC BALANCER

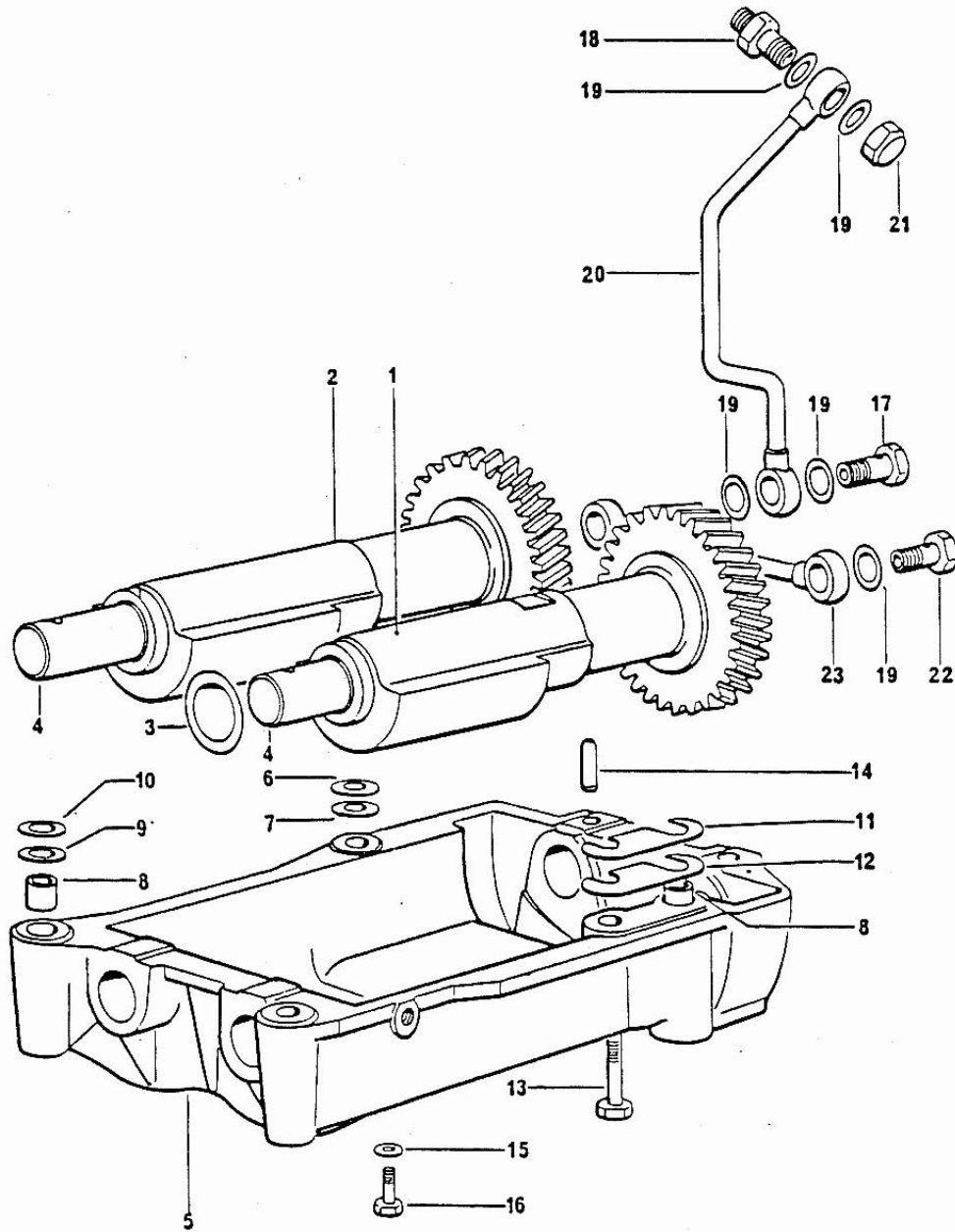

Fig.	P/n	QTY	Name
------	-----	-----	------

Notes:
[R 714 V]

1	0.044.1263.3/20	1	mass sx/lh/li
1	2.1559.115.0	2	special bushing 26x30x30
2	0.044.1261.3/10	1	mass dx/rh/re
2	2.1559.115.0	2	special bushing 26x30x30
3	2.1589.050.0/10	4	shoulder ring 26.1x38x1
4	0.044.1266.0/20	2	shaft
7	2.1579.629.0	4	spacer 12.5x26x0.1
8	2.1579.626.0	2	spacer 13.2x16x11
9	2.1579.628.0	1	spacer 16.5x26x0.1
10	2.1589.048.0	3	shoulder ring 16.5x26x0.3
11	2.1379.038.0	1	shim mm 0.1
12	2.1379.039.0	1	shim mm 0.3
13	2.0112.426.1	4	screw m 12 p.1.75x85
14	2.1631.717.0	2	roll pin 8 x 40
15	2.1474.009.1	1	spring washer 8
16	2.0112.204.2	1	screw m 8 p.1.25x14
17	2.3339.515.1	1	pipe union m 12 p.1.25
18	2.3319.041.1	1	pipe union m 12 p.1.25-p.1.75
19	2.1560.007.0	7	gasket 12.2x16
20	0.044.1562.2	1	tube
21	2.1019.048.1	1	special nut m 12 p.1.5

Section: ENGINE

CAMSHAFT

Fig.	P/n	QTY	Name
------	-----	-----	------

Notes:
[R 714 V]

1	0.044.1310.0/40	1	camshaft
2	2.3130.001.1	1	plug 1/8" gas
3	0.027.1314.0	1	flange
4	2.1470.004.2	2	lock washer 8
5	2.0112.207.2	2	screw m 8 p 1.25 x 20
6	0.062.1321.0	1	gear z=66
7	2.0139.005.1	4	screw m 10 p.1 x 25
8	0.040.1320.0	1	gear z = 33
9	2.1720.010.0	1	key 5x9
10	0.040.1323.0/10	1	gear Z = 38
11	0.052.1330.0/20	8	tappets
12	0.041.1331.3	8	rod
13	0.041.1332.0	8	sleeve
14	2.1539.020.0	8	special oil seal 13.95x2.62
15	2.1539.022.0	8	special oil seal 12.37x2.62
16	2.4019.162.1/20	8	spring 17.2x46x1.8
17	0.041.1355.3	1	transmission
18	2.1560.013.0	1	gasket 18.2x22

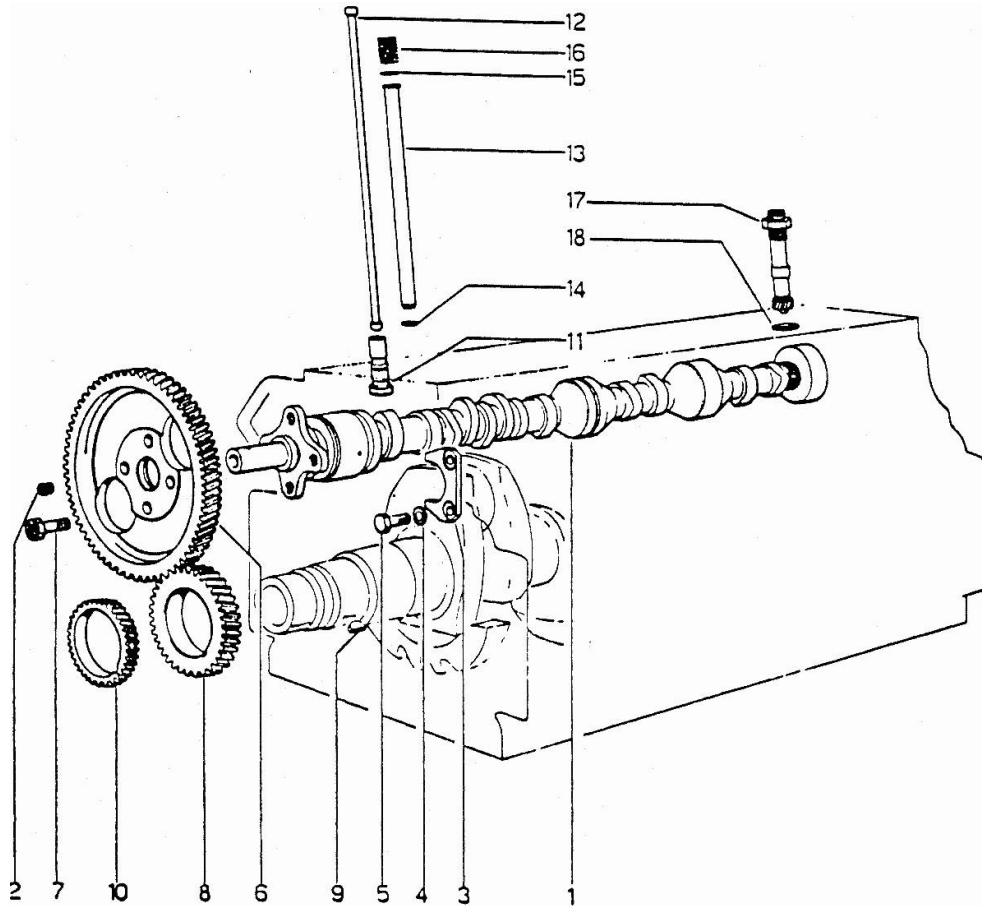

Buy Now



Our support email:

ebooklibonline@outlook.com