

CRANKCASE

| Fig. | P/n | QTY | Name |
|------|-----|-----|------|
|------|-----|-----|------|

Notes:

[R2.86 2WD] [R2.86 4WD]

| | | | |
|------------|-----------------|----|------------------------------|
| 3 | 2.3199.312.2/20 | 1 | plug m 35x1.5x9.5 |
| 5 | 2.0439.273.7 | 8 | stud bolt m 8 |
| 6 | 2.1559.188.2 | 4 | bush 11.4 x 14 x16 |
| 7 | 2.1539.259.0 | 8 | special oil seal 107.62x2.62 |
| 8 | 2.1560.010.0 | 1 | gasket 14.2 x 20 |
| 9 | 2.3199.292.0 | 1 | plug 1/4" gas |
| 11 | 0.066.1152.0/10 | 4 | gasket |
| 13 | 2.1549.154.2 | 4 | bush 4.8x5.8x16 |
| 14 | 0.015.2988.4/10 | 1 | crankcase |
| 14.1 | 2.3130.001.1 | 10 | plug 1/8" gas |
| 14.2 | 2.3130.002.1 | 2 | plug 1/4" gas |
| 14.3 | 2.3130.003.1 | 6 | plug 3/8" gas |
| 14.4.1.1.1 | 0.065.1112.7/10 | 1 | support |
| 14.4.1.2 | 2.1699.165.0 | 1 | bush 12.3x15x16 |
| 14.4.2 | 0.065.1114.0/10 | 3 | support |
| 14.4.3 | 0.065.1116.3 | 1 | support |
| 14.4.3.2 | 2.1699.165.0 | 1 | bush 12.3x15x16 |
| 14.4.5 | 0.065.1117.0 | 10 | screw m 12 x 100 |
| 14.5 | 2.3179.012.0 | 1 | plug 60 |
| 14.6 | 0.065.1140.0 | 4 | special bushing 59X55X20 |
| 14.7 | 0.065.1141.0 | 1 | special bushing 59X55X30 |
| 14.8 | 0.014.1340.0/10 | 1 | pin mm 85 |
| 25 | 0.013.4946.0/10 | 1 | sprayer nozzle |
| 26 | 2.3120.101.0 | 1 | plug m 18 p.1.5 |
| 28 | 2.1560.014.0 | 1 | washer 18.2 x 24 |

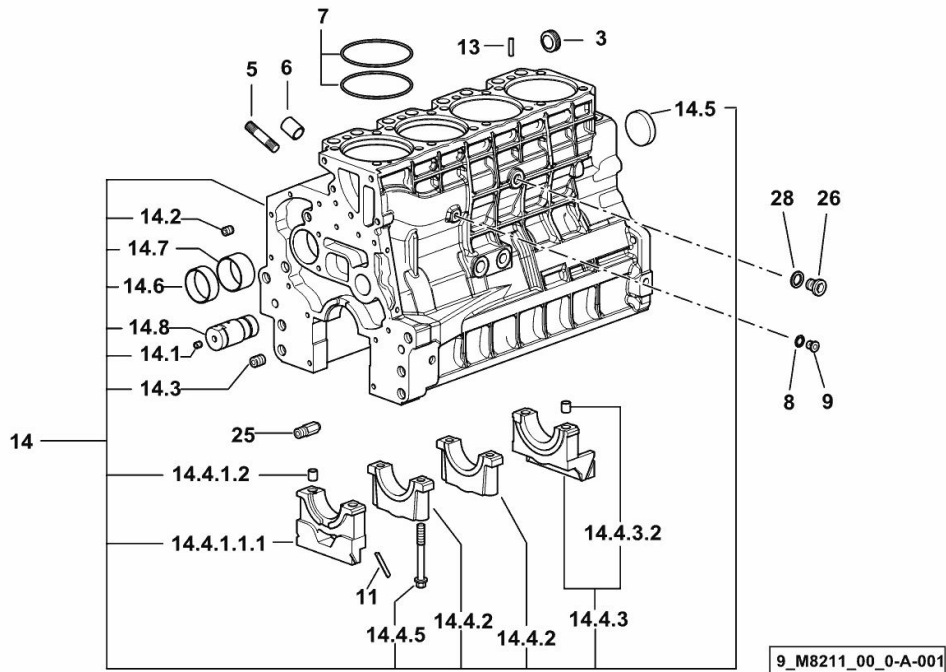

MONOBLOC ENGINE-GEARBOX CONNECTING FLANGE

| Fig. | P/n | QTY | Name |
|------|-----|-----|------|
|------|-----|-----|------|

Notes:

[R2.86 2WD] [R2.86 4WD]

| | | | |
|---|-----------------|---|-----------------------------------|
| 1 | 0.007.7752.0/30 | 1 | flange |
| 2 | 2.0112.511.2 | 8 | screw m 14 p.2 x 30 |
| 3 | 2.1651.912.0 | 2 | cylindrical plug 12x28 |
| 4 | 2.1651.917.0 | 1 | cylindrical plug 12x40 |
| 5 | 2.0432.257.7 | 1 | stud bolt m 12 p.1.75 - 1.25 x 30 |
| 6 | 2.0439.250.7 | 1 | stud bolt m 12 / m 10 x 30 |
| 7 | 0.011.9294.0/10 | 1 | bush |

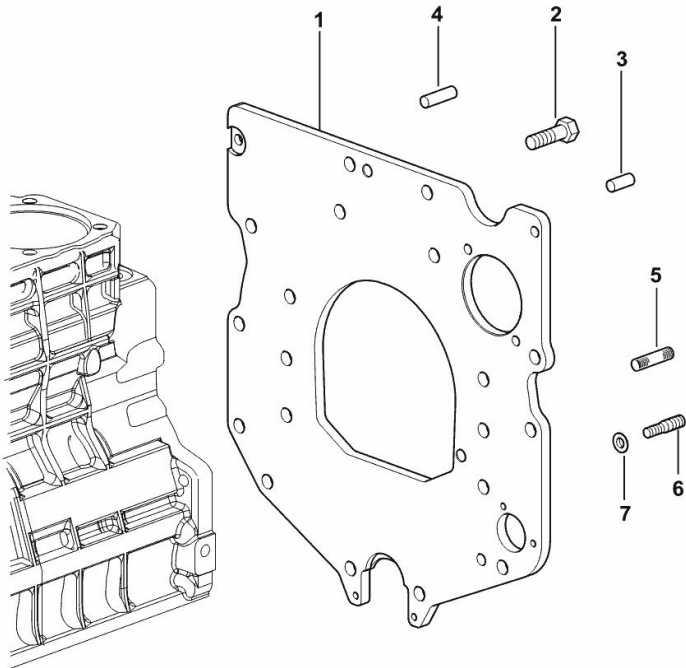

9_37311_01_0-A-001

ENGINE OIL AND TURBO PRESSURE SWITCH UNION

| Fig. | P/n | QTY | Name |
|------|-----|-----|------|
|------|-----|-----|------|

Notes:

[R2.86 2WD] [R2.86 4WD]

| | | | |
|----|-----------------|---|---------------------|
| 10 | 2.3339.787.0/10 | 1 | pipe fitting 7/16" |
| 11 | 2.3110.403.1 | 1 | plug m 14 p.1.5x12 |
| 12 | 2.1560.010.0 | 2 | gasket 14.2 x 20 |
| 13 | 2.1019.129.2/10 | 1 | nut m 18 p.1.5x12 |
| 14 | 2.1533.038.0 | 1 | oil seal 15.45x2.62 |

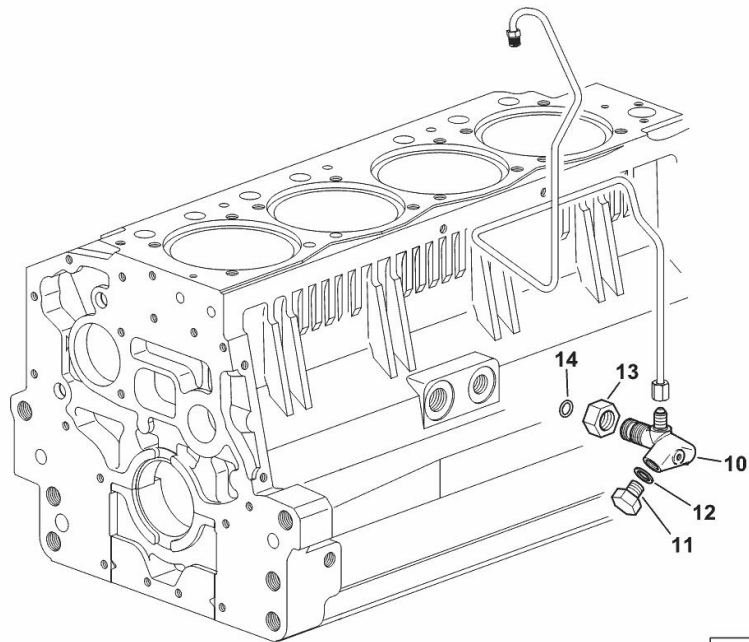

9_36615_01_0-B-001

PLUG

| Fig. | P/n | QTY | Name |
|------|-----|-----|------|
|------|-----|-----|------|

Notes:

[R2.86 2WD] [R2.86 4WD]

| | | | |
|---|--------------|---|---------------|
| 1 | 2.3130.003.1 | 1 | plug 3/8" gas |
|---|--------------|---|---------------|

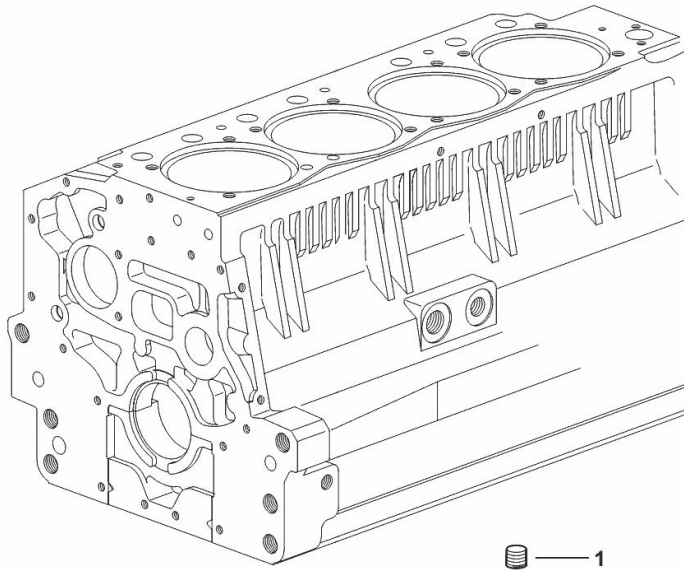

1

9_34311_06_0-A-001

CRANKSHAFT PULLEY

| Fig. | P/n | QTY | Name |
|------|-----|-----|------|
|------|-----|-----|------|

Notes:

[R2.86 2WD] [R2.86 4WD]

| | | | |
|---|-----------------|---|---------------------|
| 3 | 0.007.1457.0/30 | 1 | pulley |
| 5 | 0.085.1248.0/20 | 1 | hub |
| 6 | 2.0399.144.7/10 | 1 | screw m 20 p.1.5x51 |
| 8 | 2.1720.006.0 | 1 | key 4x6.5 |

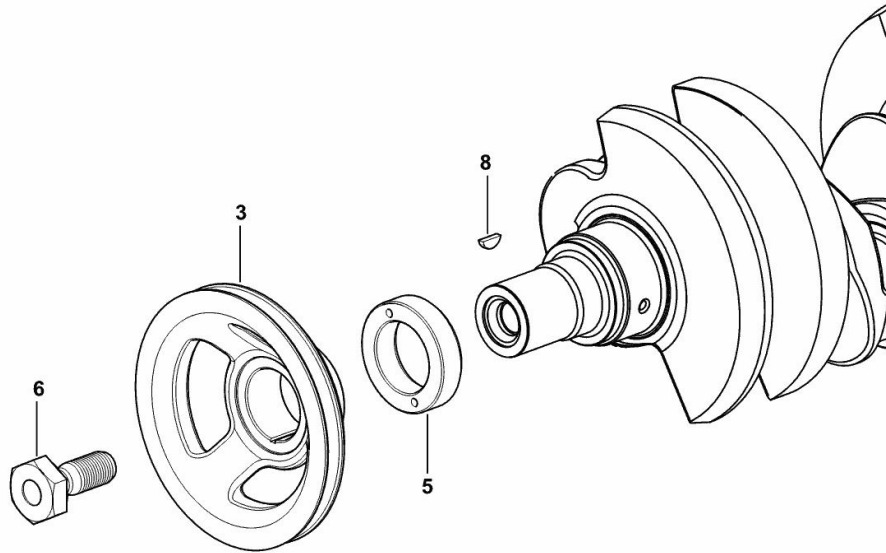

9_33312_02_0-A-001

CRANKSHAFT PULLEY

| Fig. | P/n | QTY | Name |
|------|-----|-----|------|
|------|-----|-----|------|

Notes:

- FOR TRACTORS WITH AIR CONDITIONING [R2.86 2WD] - FOR TRACTORS WITH AIR CONDITIONING [R2.86 4WD]

| | | | |
|---|-----------------|---|---------------------|
| 3 | 0.007.1458.0/40 | 1 | pulley |
| 5 | 0.085.1248.0/20 | 1 | hub |
| 6 | 2.0399.144.7/10 | 1 | screw m 20 p.1.5x51 |
| 8 | 2.1720.006.0 | 1 | key 4x6.5 |

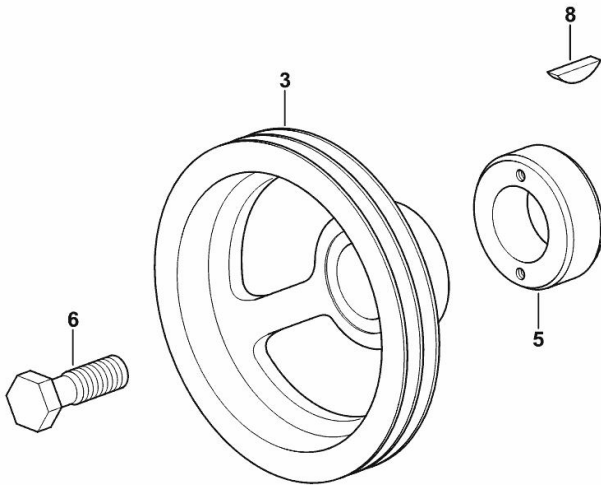

9_37512_06_0-A-001

PULSE WHEEL

| Fig. | P/n | QTY | Name |
|------|-----|-----|------|
|------|-----|-----|------|

Notes:

- FOR MODELS WITHOUT FRONT P.T.O. [R2.86 2WD] - FOR MODELS WITHOUT FRONT P.T.O. [R2.86 4WD]

| | | | |
|---|--------------|---|-------------|
| 1 | 0.011.3531.0 | 1 | gear Z = 48 |
|---|--------------|---|-------------|

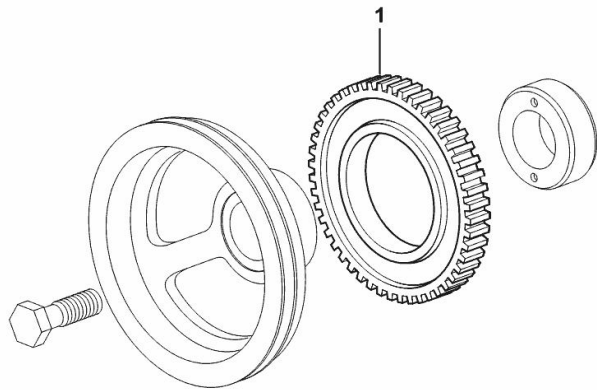

9_36812_05_0-A-001

Buy Now



Our support email:

ebooklibonline@outlook.com