

**ENGINE**

Fig.	P/n	QTY	Name
------	-----	-----	------

Notes:  
[R5.150 -> 10001]

1	6.N6303.00.0	1	engine ON ORDERING PLEASE ENGINE NO. REQUIRED
---	--------------	---	---

9\_MOT00\_00\_M-A-001

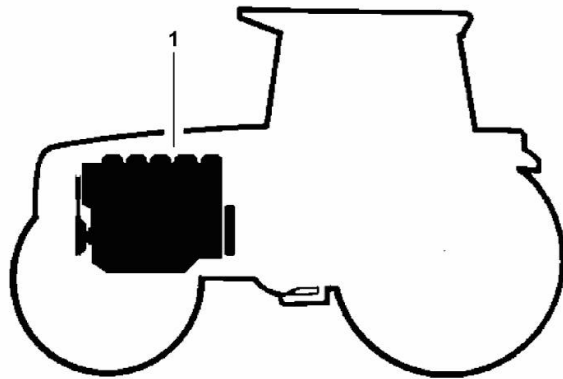

Section: B0 - ENGINE

**CRANKCASE**

Fig.	P/n	QTY	Name
------	-----	-----	------

Notes:  
[R5.150 -> 10001]

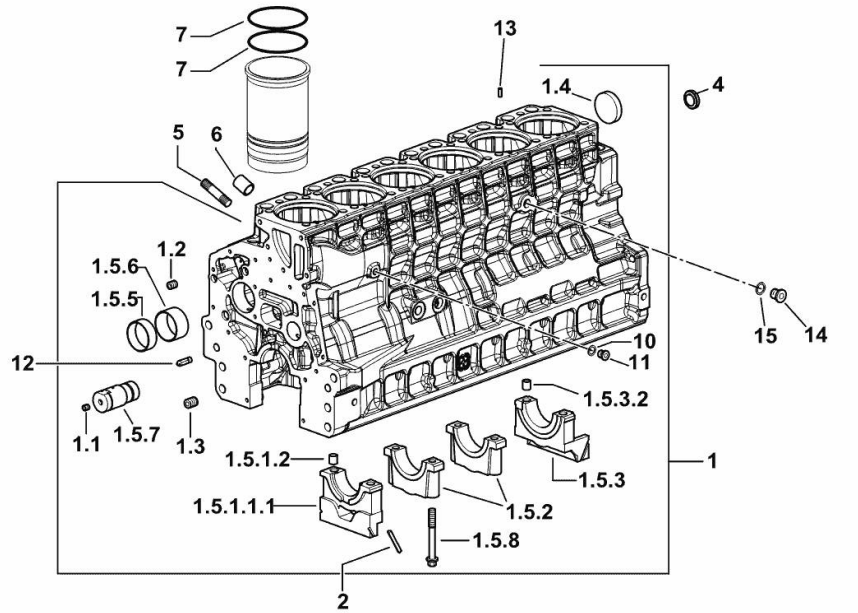

9\_N6311\_00\_0-A-001

1	0.015.3558.4/10	1	crankcase
1.1	2.3130.001.1	20	plug 1/8" gas
1.2	2.3130.002.1	4	plug 1/4" gas
1.3	2.3130.003.1	6	plug 3/8" gas
1.4	2.3179.012.0	1	plug 60
1.5.1.1.1	0.065.1112.7/10	1	support
1.5.1.2	2.1699.165.0	1	bush 12.3x15x16
1.5.2	0.065.1114.0/10	5	support
1.5.3	0.007.0848.3/20	1	support
1.5.3.2	2.1699.165.0	1	bush 12.3x15x16
1.5.5	0.065.1140.0	6	special bushing 59X55X20
1.5.6	0.065.1141.0	1	special bushing 59X55X30
1.5.7	0.014.1340.0/10	1	pin mm 85
1.5.8	0.065.1117.0	14	screw m 12 x 100
2	0.066.1152.0/10	4	gasket
4	2.3199.312.2/20	1	plug m 35x1.5x9.5
5	2.0439.279.7	12	stud bolt m 8 p.1 x 25
6	2.1559.188.2	6	bush 11.4 x 14 x16
7	2.1539.259.0	12	special oil seal 107.62x2.62
10	2.1560.010.0	1	gasket 14.2 x 20
11	2.3199.292.0	1	plug 1/4" gas
12	0.013.4946.0/10	1	sprayer nozzle
13	2.1549.154.2	6	bush 4.8x5.8x16
14	2.3120.101.0	1	plug m 18 p.1.5
15	2.1560.014.0	1	washer 18.2 x 24

**MONOBLOC ENGINE-GEARBOX CONNECTING FLANGE**

Fig.	P/n	QTY	Name
------	-----	-----	------

**Notes:**

[R5.150 -&gt; 10001]

1	2.3131.003.2	1	plug m 16 p.1.5
6	2.0439.250.7	1	stud bolt m 12 / m 10 x 30
7	0.011.9294.0/10	1	bush
8	0.007.0809.0/20	1	flange
9	2.0112.513.2	11	screw m 14 p.2 x 35
13	2.1651.911.0	2	cylindrical plug
15	2.0432.257.7	1	stud bolt m 12 p.1.75 - 1.25 x 30
16	2.0312.520.2	2	screw m 14 p.2x70

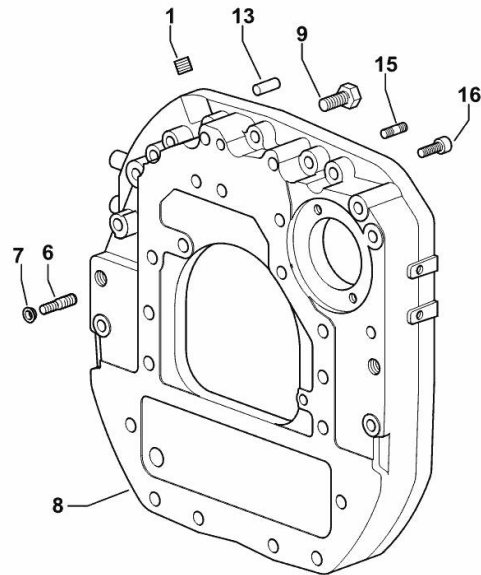

9\_N0411\_01\_0-A-001

**ENGINE OIL AND TURBO PRESSURE SWITCH UNION**

Fig.	P/n	QTY	Name
------	-----	-----	------

**Notes:**

[R5.150 -&gt; 10001]

23	2.3339.673.0/10	1	pipe fitting
26	2.3110.403.1	1	plug m 14 p.1.5x12
27	2.1560.010.0	1	gasket 14.2 x 20
28	2.1019.129.2/10	1	nut m 18 p.1.5x12
29	2.1533.038.0	1	oil seal 15.45x2.62

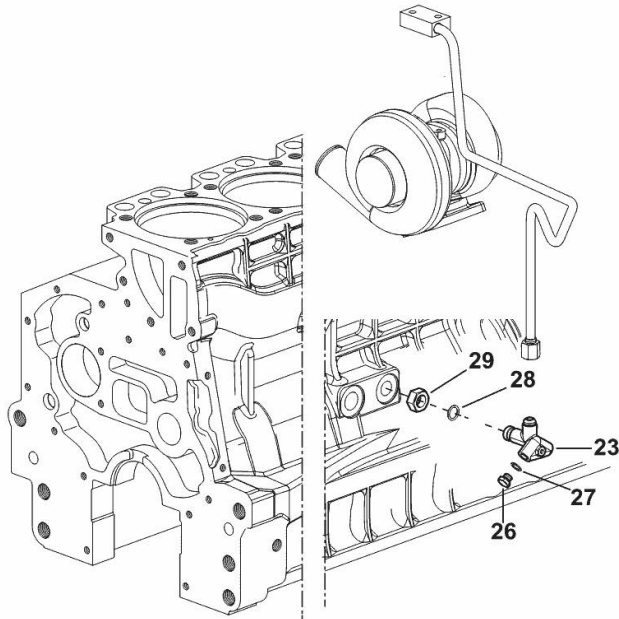

9\_N6315\_03\_0-B-001

**ENGINE LIFTING BRACKET**

Fig.	P/n	QTY	Name
------	-----	-----	------

**Notes:**

[R5.150 -&gt; 10001]

31	2.1310.004.2	2	flat washer 8.4x17
32	2.0112.207.2	2	screw m 8 p 1.25 x 20
36	0.008.9433.0	1	bracket

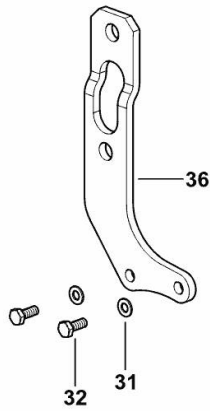

9\_N6318\_01\_0-C-001

Section: B0 - ENGINE

**ENGINE FLYWHEEL**

Fig.	P/n	QTY	Name
------	-----	-----	------

**Notes:**

[R5.150 -&gt; 10001]

1	0.078.1241.3	1	flywheel
1.2	0.065.1242.0	1	crown wheel Z = 123
2	0.288.3625.0	1	flange
3	2.0139.023.2	6	screw
4	2.1651.915.0	1	pin 12x35

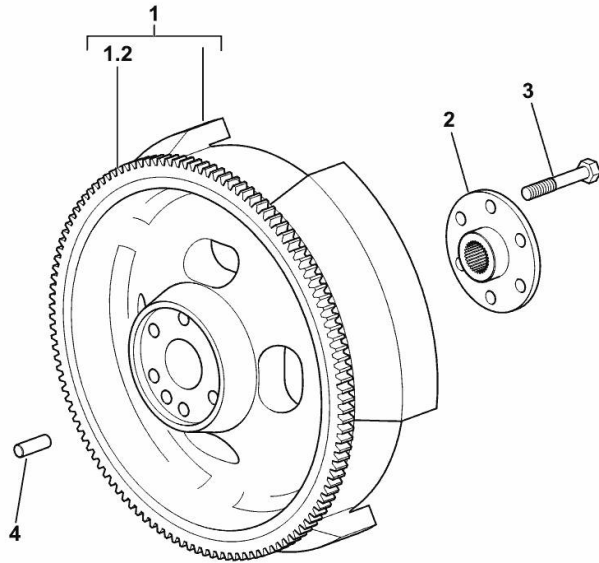

9\_N0412\_01\_0-A-001

**CRANKSHAFT**

Fig.	P/n	QTY	Name
------	-----	-----	------

Notes:  
[R5.150 -> 10001]

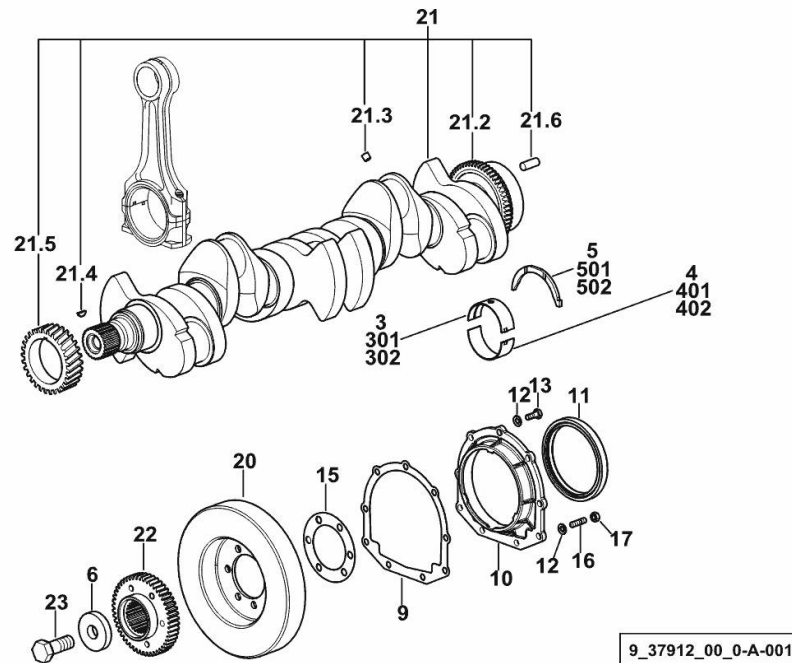

3	0.065.1215.0/10	7	main half bushing STANDARD
4	0.065.1216.0/10	7	main half bushing STANDARD
5	0.065.1218.0	4	shim STANDARD
6	2.1599.524.7	1	washer 21x60x12
9	0.065.1254.0/20	1	gasket
10	0.007.0851.0/10	1	cover
11	2.1529.073.0	1	special oil seal 110x130x13
12	2.1475.002.2	9	conical washer 8
13	2.0112.207.2	7	screw m 8 p 1.25 x 20
15	2.1589.137.0	2	shoulder ring 71x110x1
16	2.0432.003.7	2	stud bolt m 8 p.1.25 / p.1 x 20
17	2.1011.105.2	2	nut m 8 p.1.25
20	0.009.3704.3	1	antivibration pulley
21	0.010.4320.3/30	1	crankshaft
21.2	0.007.0855.0/10	1	gear
21.3	2.3130.001.1	6	plug 1/8" gas
21.4	2.1720.006.0	1	key 4x6.5
21.5	0.007.1188.0/30	1	gear Z = 29
21.6	2.1651.915.0	1	pin 12x35
22	0.011.2206.0/20	1	hub
23	2.0399.144.7/10	1	screw m 20 p.1.5x51
301	0.065.1215.7		main half bushing - mm 0.25
302	0.065.1215.8		main half bushing - mm 0.50
401	0.065.1216.7		main half bushing - mm 0.25
402	0.065.1216.8		main half bushing - mm 0.50
501	0.065.1218.7		shim + mm 0.10
502	0.065.1218.8		shim + mm 0.15

**Buy Now**



Our support email:

[ebooklibonline@outlook.com](mailto:ebooklibonline@outlook.com)