

Section: ENGINE  
**CRANKCASE**

Fig.	P/n	QTY	Name
------	-----	-----	------

Notes:  
 [RACING 190 -> 3001]

1	0.007.1102.6/20	1	crankcase
2	0.065.1112.7	1	support
3	2.1699.165.0	1	bush 12.3x15x16
4	0.065.1114.0/10	5	support
5	0.007.0848.3/10	1	support
6	2.1699.165.0	1	bush 12.3x15x16
7	0.065.1140.0	6	special bushing 59X55X20
8	0.065.1141.0	1	special bushing 59X55X30
9	0.066.1151.0	1	pin
10	2.3130.001.1	14	plug 1/8" gas
11	2.3130.002.1	2	plug 1/4" gas
12	2.3130.003.1	8	plug 3/8" gas
15	2.3179.012.0	1	plug 60
16	0.065.1117.0	14	screw m 12 x 100
17	2.1539.047.0	1	special oil seal 26.7x1.78
18	2.3199.405.2	1	plug m 28 p.1.5
19	2.0432.003.7	18	stud bolt m 8 p.1.25 / p.1 x 20
20	2.1559.188.2	6	bush 11.4 x 14 x16
21	2.1539.193.0	12	special oil seal 107.62x2.62
22	0.011.0183.0/20	6	engine cylinder
23	2.1549.154.2	6	bush 4.8x5.8x16
24	2.1560.010.0	1	gasket 14.2 x 20
25	2.3199.292.0	1	plug 1/4" gas
26	0.007.0809.0/20	1	flange
27	2.0112.513.2	11	screw m 14 p.2 x 35
28	2.0432.328.7	4	stud bolt m 14 p.2-1.5x130
30	2.0112.534.2	2	screw m 14 p.2x125
31	2.1651.911.0	2	cylindrical plug
32	2.1011.108.2	4	nut m 14 p.2
33	2.0432.255.7	2	stud bolt m 12 p.1.75-1.25x25
34	2.0312.520.1	2	screw m 14 p.2x70
35	0.066.1152.0/10	4	gasket
36	2.1560.014.0	1	washer 18.2 x 24
37	2.3120.101.0	1	plug m 18 p.1.5
38	0.337.0050.6	1	gasket set
39	2.3120.101.0	1	plug m 18 p.1.5
40	2.1560.014.0	1	washer 18.2 x 24

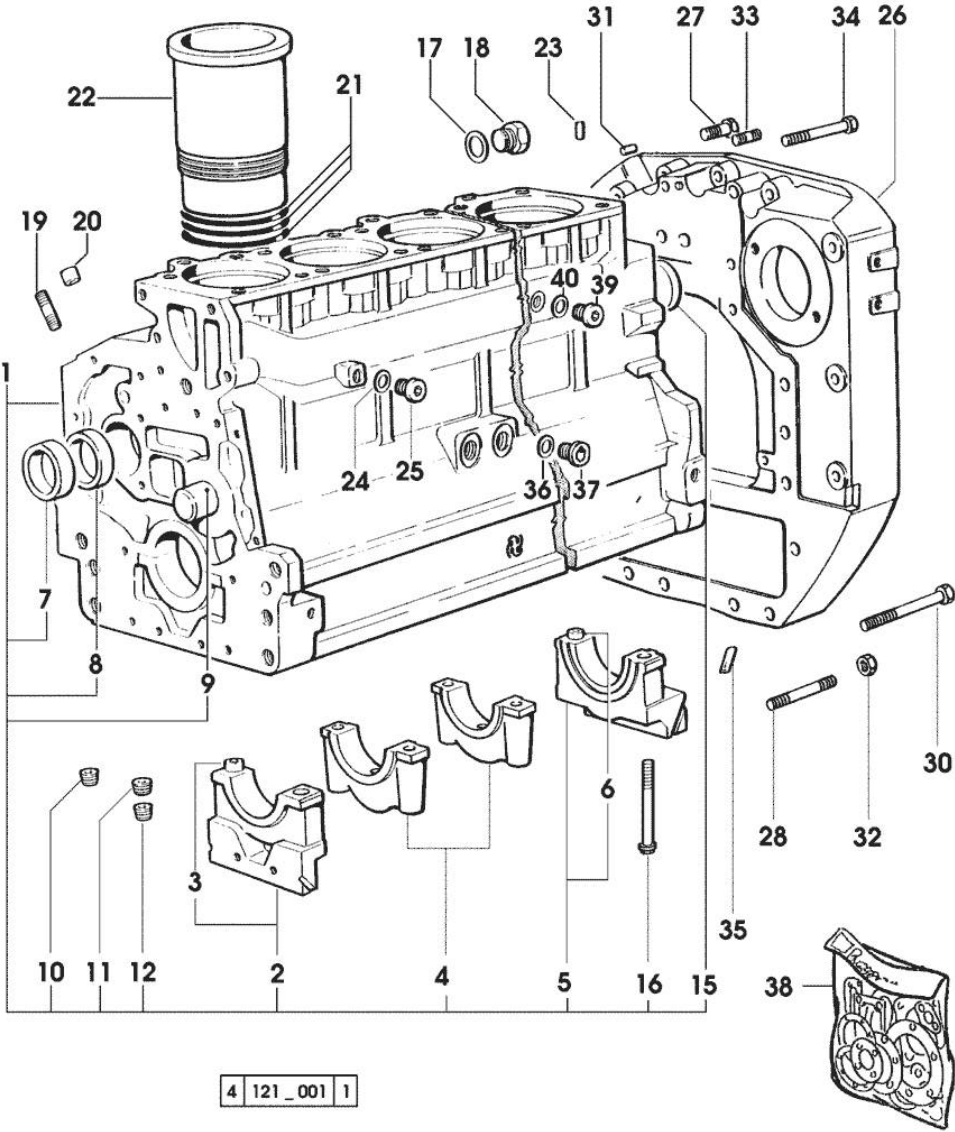

Section: ENGINE  
TIMING CASE

Fig.	P/n	QTY	Name
------	-----	-----	------

Notes:  
[RACING 190 -> 3001]

1	0.007.1262.3/50	1	guard
2	0.007.1271.0/10	1	small column m 8 p.1.25 / L = mm 60
3	0.007.1272.0/10	2	small column m 8 p.1.25 / L = mm 50
5	2.1310.004.2	3	flat washer 8.4x17
7	2.0112.205.2	3	screw m 8 p.1.25 x 16

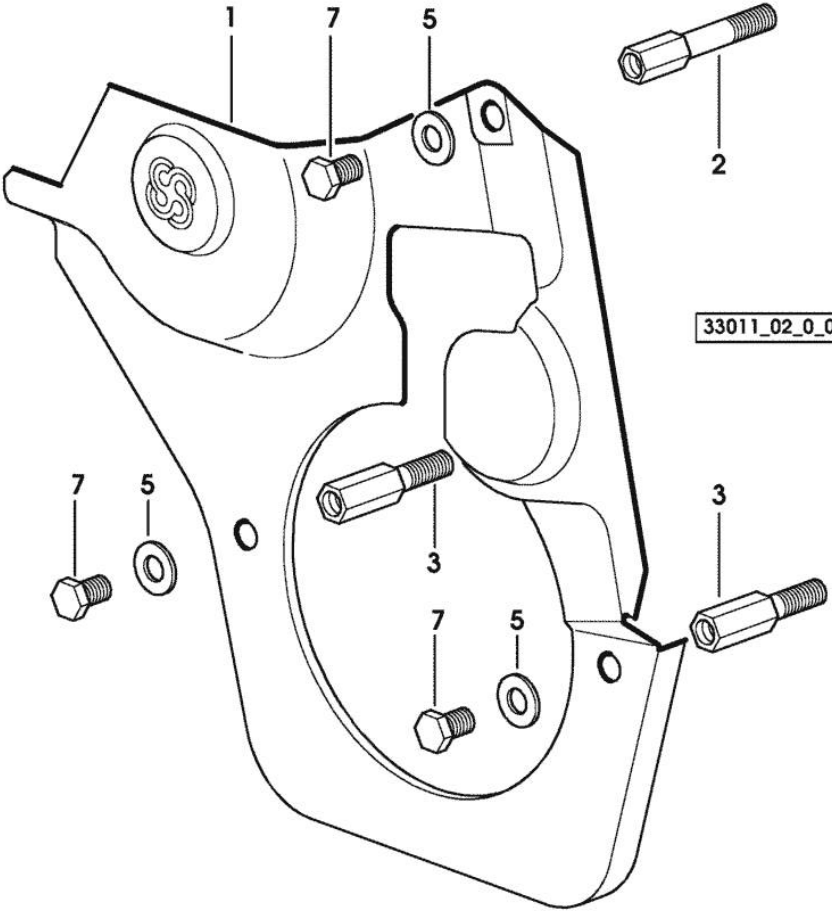

Section: ENGINE  
TIMING CASE

Fig.	P/n	QTY	Name
------	-----	-----	------

Notes:  
[RACING 190 -> 3001]

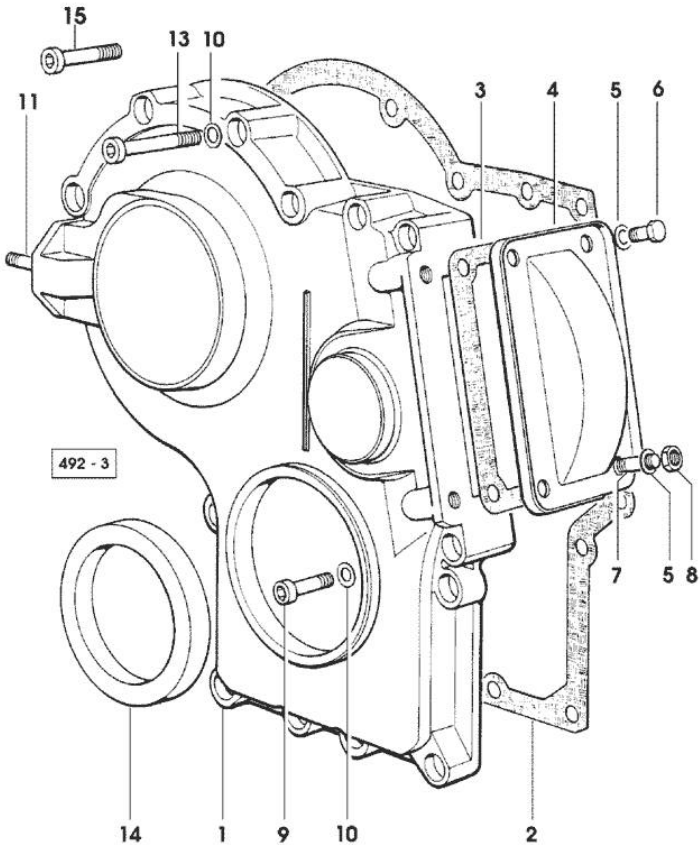

1	0.065.1132.0/60	1	guard
2	0.065.1150.0/30	1	gasket
3	0.065.1152.0	1	gasket
4	0.065.1151.0	1	cover
5	2.1470.004.2	4	lock washer 8
6	2.0112.205.2	2	screw m 8 p.1.25 x 16
7	2.0432.003.7	2	stud bolt m 8 p.1.25 / p.1 x 20
8	2.1011.405.2	2	nut m 8 p.1
9	2.0312.214.2	3	screw m 8 p.1.25 x 40
10	2.1480.014.1	15	washer 8
11	2.0432.003.7	2	stud bolt m 8 p.1.25 / p.1 x 20
13	2.0312.219.2	4	screw m 8 p.1.25x65
14	2.1529.141.0	1	special oil seal
15	2.0312.208.2	8	screw m 8 p.1.25 x 25

Section: ENGINE

**CRANKSHAFT**

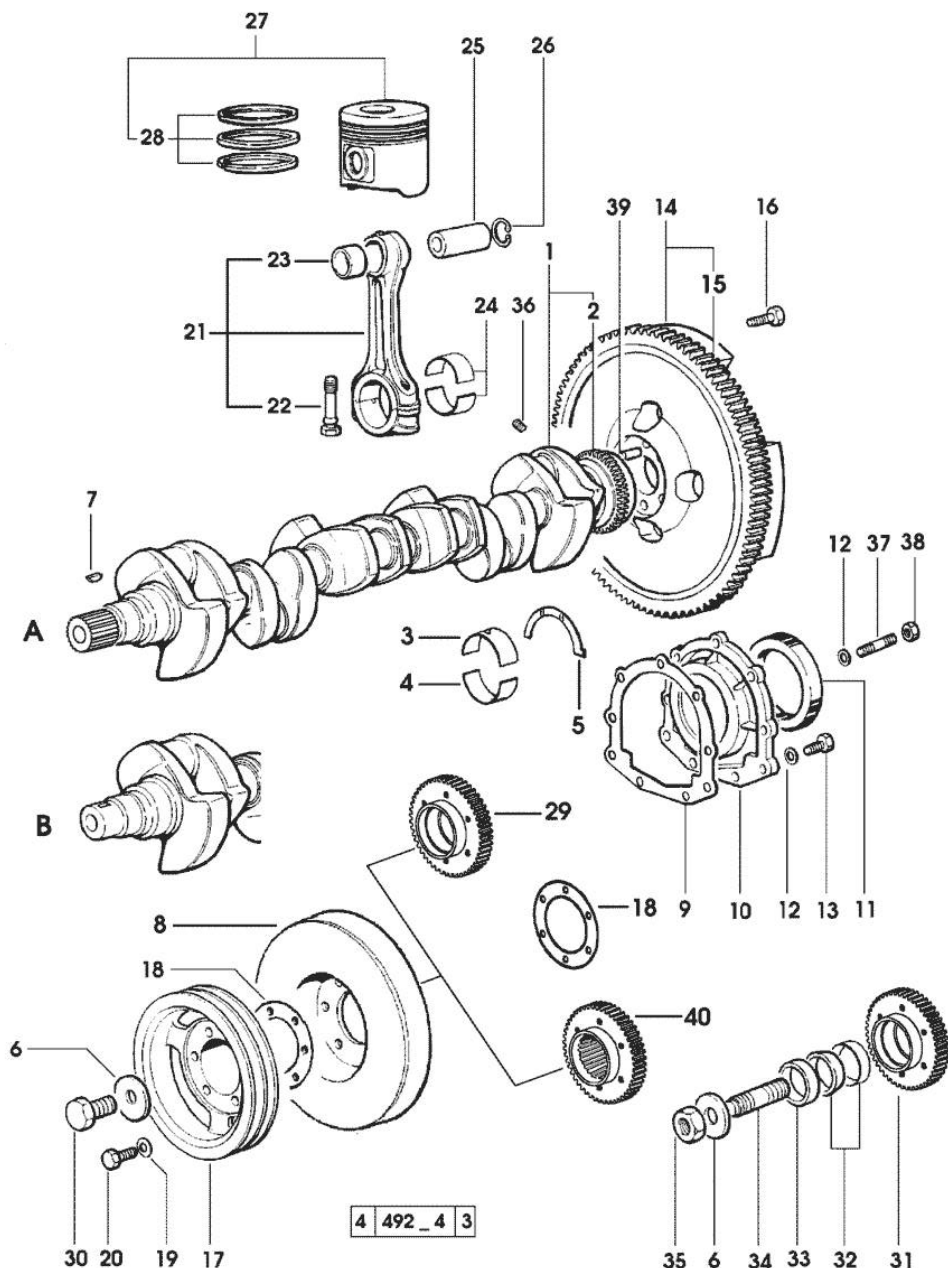

Fig.	P/n	QTY	Name
<b>Notes:</b> [RACING 190 -> 3001]			
1	0.010.4320.3/20	1	crankshaft (...) <= " B " * N.1 011.2206.0/10
2	0.007.0855.0	1	gear
3	0.065.1215.0	7	main half bushing STANDARD
3	0.065.1215.7		main half bushing - mm 0.25
3	0.065.1215.8		main half bushing - mm 0.50
4	0.065.1216.0	7	main half bushing
4	0.065.1216.7		main half bushing - mm 0.25
4	0.065.1216.8		main half bushing - mm 0.50
5	0.065.1218.0	4	shim STANDARD
5	0.065.1218.7		shim + mm 0.10
5	0.065.1218.8		shim + mm 0.15
6	2.1599.524.7	1	washer 21x60x12
7	2.1720.006.0	1	key 4x6.5
8	0.007.1010.3	1	antivibration pulley
9	0.065.1254.0/20	1	gasket
10	0.007.0851.0/10	1	cover
11	2.1529.073.0	1	special oil seal 110x130x13
12	2.1475.002.2	9	conical washer 8
13	2.0112.207.2	7	screw m 8 p 1.25 x 20
14	0.007.0655.3/20	1	flywheel
15	0.065.1242.0	1	crown wheel Z = 123
16	2.0119.174.0/10	6	screw m 12 p.1.25x45
17	0.007.0962.0/20	1	pulley
18	2.1589.137.0		shoulder ring 71x110x1
19	2.1470.006.2	6	lock washer 10
20	2.0112.322.2	6	screw m 10 p.1.5x65
21	0.007.1395.3/20	6	engine connecting rod
22	2.0399.213.0	12	screw m 12 p.1.25x61.5
23	2.1559.255.0	6	special bushing 34.60x39.130x34.65
24	0.065.1225.0	12	con.rod half bushing STANDARD - A = 28.75 -> 29.00
24	0.065.1225.7		con.rod half bushing - mm 0.25
24	0.065.1225.8		con.rod half bushing - mm 0.50
25	0.038.1236.0/10	6	piston pin Ø 18 / Ø 35 / L = mm 90
26	2.1411.014.1	12	circlip 35
27	0.340.0060.6/10	6	complete piston
27	0.383.0060.6	6	complete piston - EXPORT U.S.A.
28	0.338.0052.6/10	6	piston ring set
29	0.011.2140.0/10	1	hub

**CRANKSHAFT**

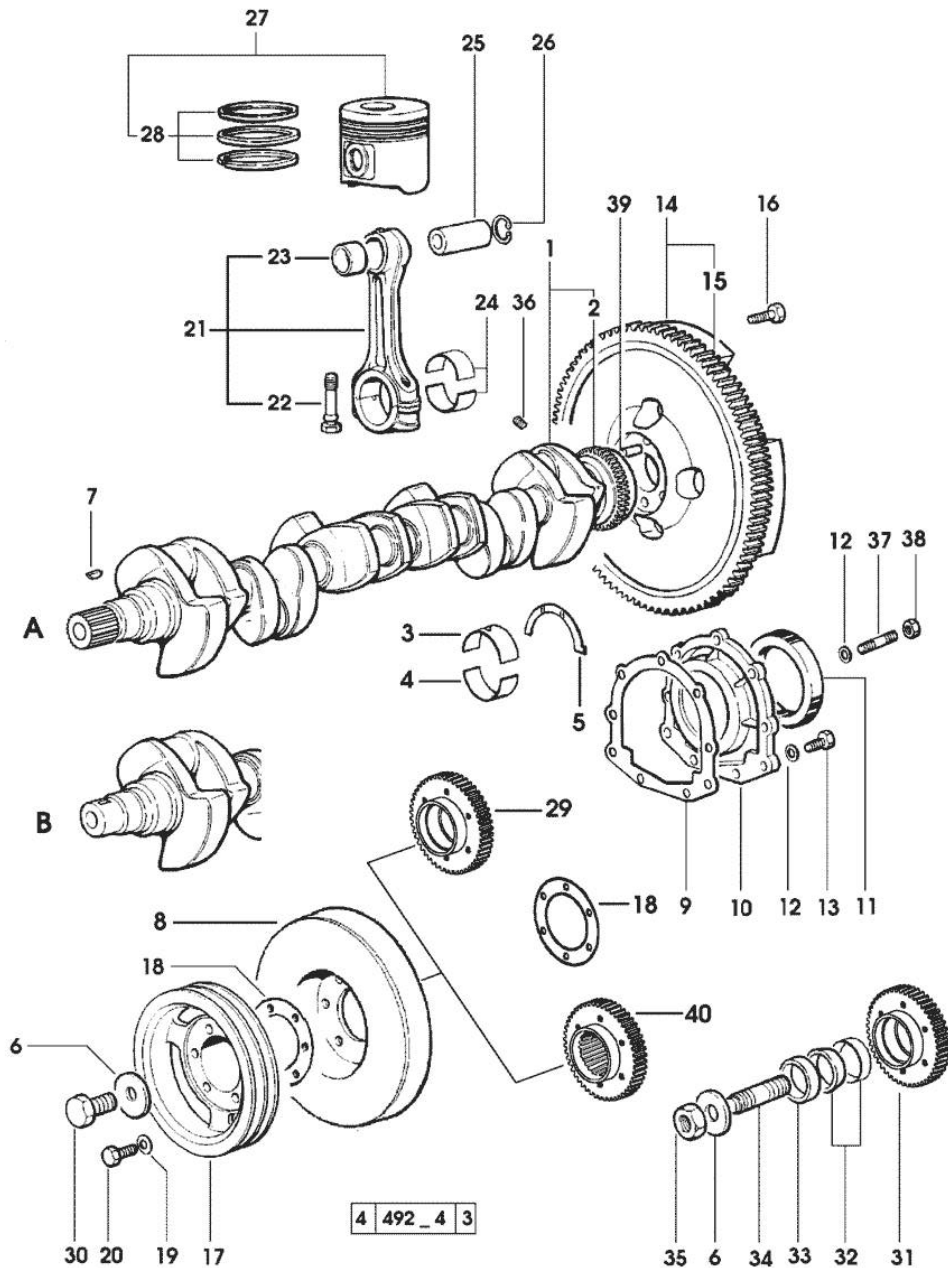

Fig.	P/n	QTY	Name
30	2.0399.144.7/10	1	- X B (...) <= screw m 20 p.1.5x51
31	0.011.2141.0/10	1	hub - FOR MODELS EQUIPPED WITH FRONT P.T.O. - X B (...) <=
32	0.035.1263.0	2	ring - X B (...) <=
33	2.1579.949.0	1	ring 50.2x56.8x8 - X B (...) <=
34	2.0439.195.7	1	stud bolt m 20 p.1.5x80 - X B (...) <=
35	2.1019.094.7	1	nut m 20 p.1.5 - X B (...) <=
36	2.3130.001.1	6	plug 1/8" gas
37	2.0432.003.7	2	stud bolt m 8 p.1.25 / p.1 x 20
38	2.1011.105.2	2	nut m 8 p.1.25
39	2.1651.915.0	1	pin 12x35
40	0.011.2206.0/10	1	hub - X A => (...)

Section: ENGINE

**CAMSHAFT**

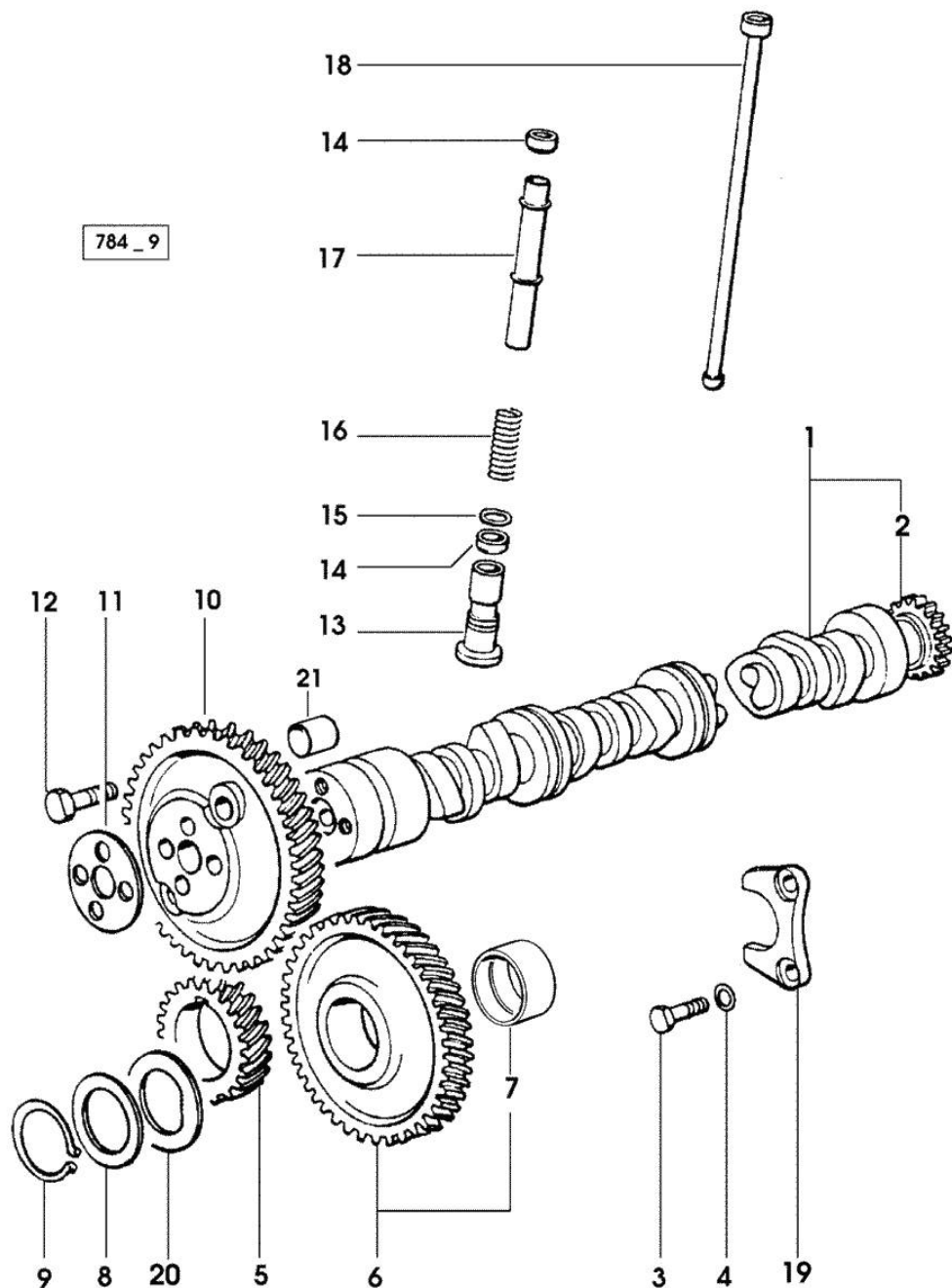

Fig.	P/n	QTY	Name
<b>Notes:</b>			
[RACING 190 -> 3001]			
1	0.010.4968.3/10	1	camshaft - EXPORT U.S.A. - X 165HP - 190HP - HI.PER.
1	0.075.1310.3/30	1	camshaft
2	0.065.1324.0/10	1	gear Z = 32
3	2.0312.205.2	2	screw
4	2.1480.014.1	2	washer 8
5	0.007.1188.0/20	1	gear Z = 29
6	0.007.1177.3/10	1	gear z = 57 - WITH RED IDENTIFICATION STAMP
6	0.007.1178.3/10	1	gear z = 57 - WITH YELLOW IDENTIFICATION STAMP
6	0.007.1179.3/10	1	gear z = 57 - WITH GREEN IDENTIFICATION STAMP
7	2.1559.185.0/10	1	bushing
8	0.065.1352.0	1	shim
9	2.1410.016.1	1	circlip 40
10	0.065.1354.0/20	1	gear z=58
11	0.065.1350.0	1	small disc
12	2.0132.207.2	4	screw m 10 p.1 x 25
13	0.065.1330.0	12	tappets
14	2.1569.114.0/10	24	gasket 14x18.5x8
15	2.1599.437.0	12	shoulder ring
16	2.4019.300.1/10	12	spring 18.5x52x2
17	0.065.1332.0	12	sleeve
18	0.065.1331.2	12	rod
19	0.065.1353.0	1	small plate
20	0.065.1351.0	2	shoulder ring
21	2.1559.398.0	1	bushing 10.5x13x12

Section: ENGINE  
**CYLINDER HEAD**

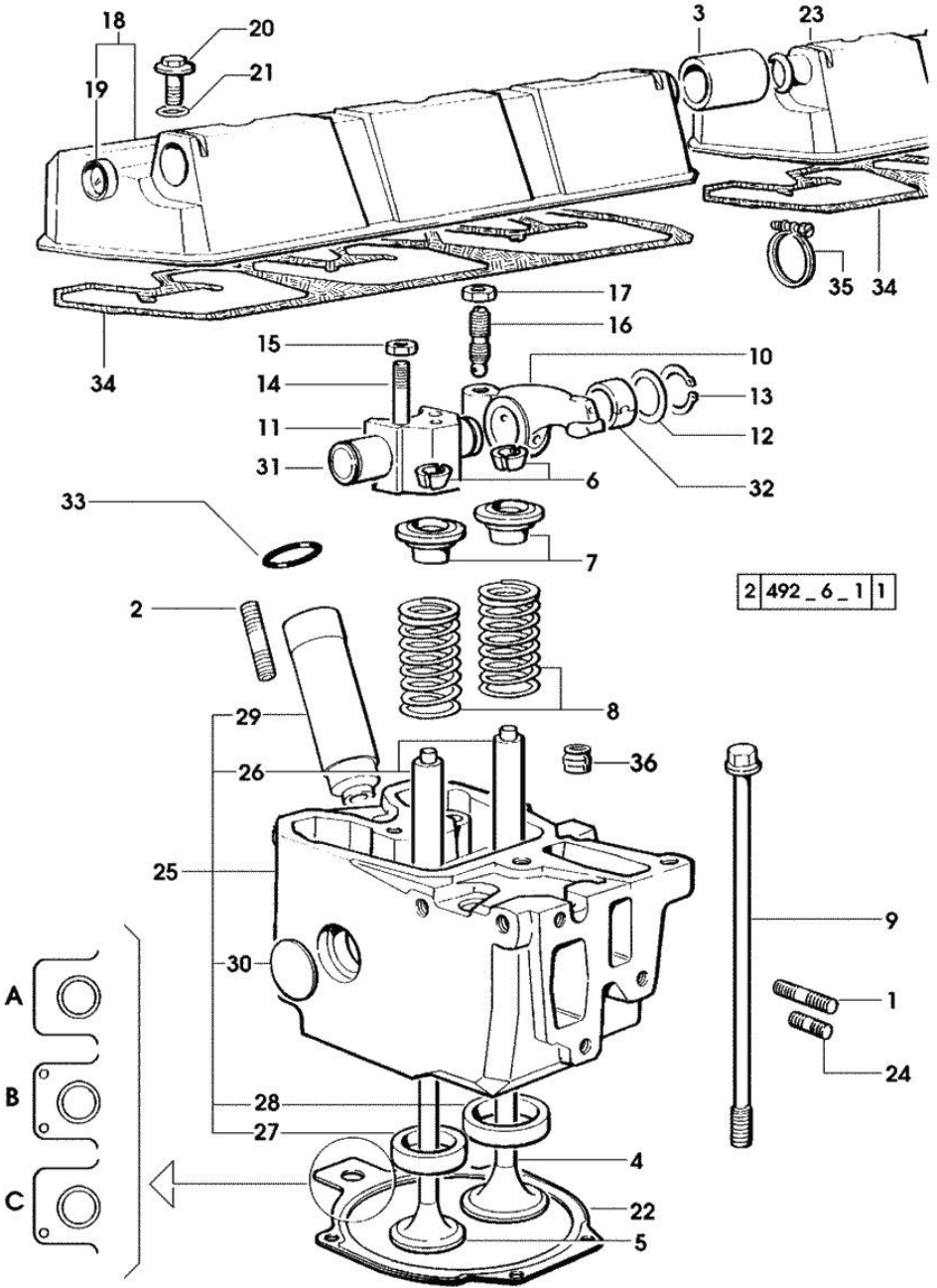

Fig.	P/n	QTY	Name
------	-----	-----	------

Notes:  
 [RACING 190 -> 3001]

1	2.0432.011.7	6	stud bolt m 8 p.1.25 / p.1 x 40
2	2.0432.161.7	6	stud bolt m 10 p.1.5 / p.1.25 x 40
3	0.075.1452.0/10	1	sleeve
4	0.007.1146.0/10	6	inlet valve mm 43.63 / Ø mm 9
5	0.007.1147.0/10	6	exhaust valve mm 39.1 / Ø mm 9
6	0.074.1423.0	24	conical valve cotter
7	0.066.1425.0	12	cup
8	2.4019.287.0	12	spring
9	0.066.1443.0/10	24	screw
10	0.066.1432.0	6	rocker arm
11	0.066.1430.0/10	6	support
12	2.1599.432.0	12	shoulder ring
13	2.1410.055.7	12	circlip 19
14	2.0432.163.7	6	stud bolt m 10 p.1.5 / p.1.25 x 45
15	2.1011.421.2	12	nut m 10 p.1.25
16	0.021.1434.0	12	screw
17	2.1011.405.2	12	nut m 8 p.1
18	0.078.1440.3	1	cover
19	2.3171.008.4	1	plug 20
20	2.0399.130.2/10	6	screw m 8x36x44
21	2.1532.035.0	6	oil seal 14x1.78
22	0.078.1451.0/40	6	head gasket -A-
22	0.078.1452.0/30	6	head gasket -B-
22	0.078.1453.0/40	6	head gasket -C-
23	0.078.1450.3	1	cover
24	2.0432.005.7	6	stud bolt m 8 p.1.5 / p.1 x 25
25	0.007.1360.3/60	6	head
26	0.007.1779.0/10	12	valve guide
27	0.066.1427.0	6	valve seat
28	0.078.1426.0	6	valve seat
29	0.010.6041.0	6	bush
30	2.3170.012.1	2	expansion plug 30
31	0.066.1431.0	1	pin
32	2.1559.021.0/40	1	bushing 15x19x22
33	2.1530.051.0	6	oil seal 20.22x3.53
34	0.009.3877.0/10	2	tappet gasket
35	2.6859.052.2	2	clamp
36	2.1519.117.0	12	special oil seal

**Buy Now**



Our support email:

[ebooklibonline@outlook.com](mailto:ebooklibonline@outlook.com)