

STRIKE 115.4 T4i -> ZKDAW10200TL10001

Section: B0 - ENGINE

Ref: B0.00.4 (1)

LIGHT ENGINE 80 kW

Fig.	P/n	QTY	Name
------	-----	-----	------

Notes:
[STRIKE 115.4 T4i 2WD -> ZKDAW10100TL10001] [STRIKE 115.4 T4i 4WD -> ZKDAW10200TL10001]

1	I6.K8101.00.0	1	engine 80 kW ON ORDERING PLEASE ENGINE NO. REQUIRED
---	---------------	---	---

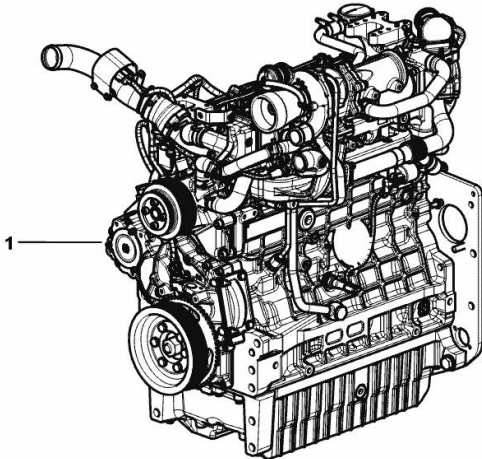

9_MOTBJ2_00_0-A-001

STRIKE 115.4 T4i -> ZKDAW10200TL10001

Section: B0 - ENGINE

Ref: B0.00.5 (1)

LIGHT ENGINE 80 kW

Fig.	P/n	QTY	Name
------	-----	-----	------

Notes:
- NOT FOR EUROPEAN MARKET [STRIKE 115.4 T4i 2WD -> ZKDAW10100TL10001] - NOT FOR EUROPEAN MARKET [STRIKE 115.4 T4i 4WD -> ZKDAW10200TL10001]

1	I6.K8105.00.0	-	engine 80 kW ON ORDERING PLEASE ENGINE NO. REQUIRED
---	---------------	---	---

9_MOT4CYL_00_0

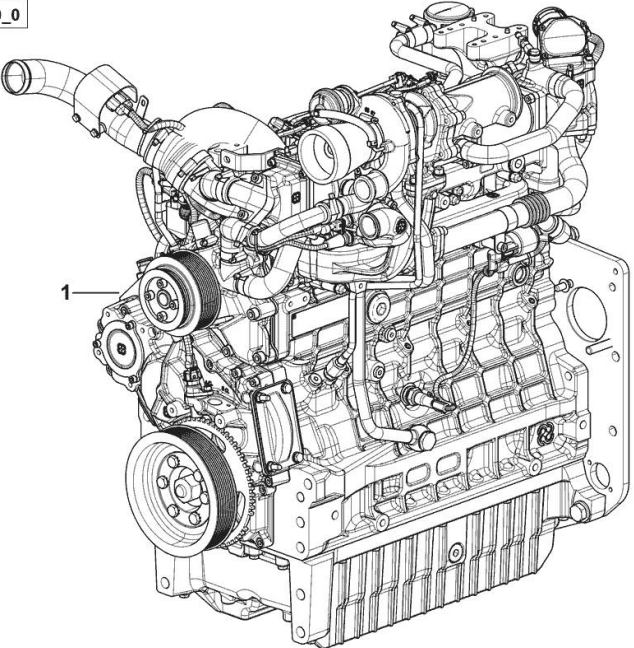

STRIKE 115.4 T4i -> ZKDAW10200TL10001

Section: B0 - ENGINE

Ref: B0.01.0 (1)

CRANKCASE

Fig.	P/n	QTY	Name
------	-----	-----	------

Notes:

[STRIKE 115.4 T4i 2WD -> ZKDAW10100TL10001] [STRIKE 115.4 T4i 4WD -> ZKDAW10200TL10001]

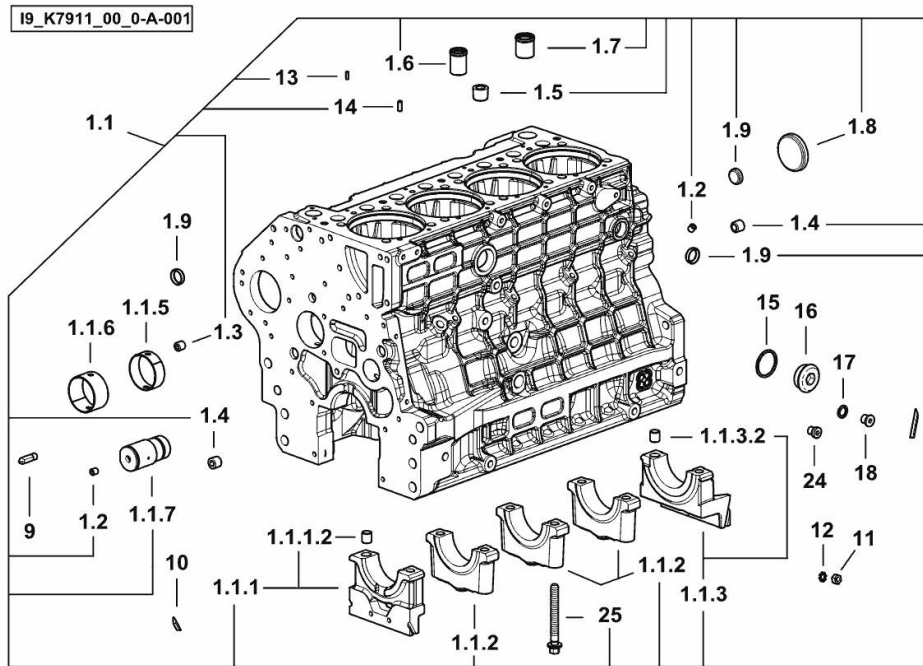

1.1	0.020.4332.3/20	1	crankcase
1.1.1	0.019.5106.3	1	support
1.1.1.2	2.1699.165.0	1	bush 12.3x15x16
1.1.2	0.019.5107.7	3	support
1.1.3	0.019.5108.3	1	support
1.1.3.2	2.1699.165.0	1	bush 12.3x15x16
1.1.5	0.065.1140.0	4	special bushing 59X55X20
1.1.6	0.065.1141.0	1	special bushing 59X55X30
1.1.7	0.019.4412.0	1	pin
1.2	2.3130.001.7	15	plug
1.3	2.3130.002.7	2	plug 1/4" gas
1.4	2.3130.003.7	4	plug 3/8" gas
1.5	2.3130.005.7	3	plug
1.6	0.019.4146.0	1	tube
1.7	0.019.6173.0	1	tube
1.8	2.3179.012.0	1	plug 60
1.9	2.3171.010.4	5	plug 25
9	0.019.4415.0/10	1	tube
10	0.066.1152.0/10	4	gasket
11	2.1011.405.2	2	nut m 8 p.1
12	2.1470.004.2	4	lock washer 8
13	2.1651.305.0	4	pin 4 x 12
14	2.1651.507.0	4	pin 6 x 16
15	2.1560.027.0	1	copper gasket 38.3x44
16	2.3139.031.2	1	plug
17	2.1560.010.0	1	gasket 14.2 x 20
18	2.3199.292.0	1	plug 1/4" gas
24	2.3139.024.2	1	plug m 12 p.1.5 (-> 10001)
25	2.0399.367.7	10	screw

STRIKE 115.4 T4i -> ZKDAW10200TL10001

Section: B0 - ENGINE

Ref: B0.01.1 (1)

CYLINDER LINER O-RING

Fig.	P/n	QTY	Name
------	-----	-----	------

Notes:
[STRIKE 115.4 T4i 2WD -> ZKDAW10100TL10001] [STRIKE 115.4 T4i 4WD -> ZKDAW10200TL10001]

16	2.1539.259.0	8	special oil seal 107.62x2.62
----	--------------	---	------------------------------

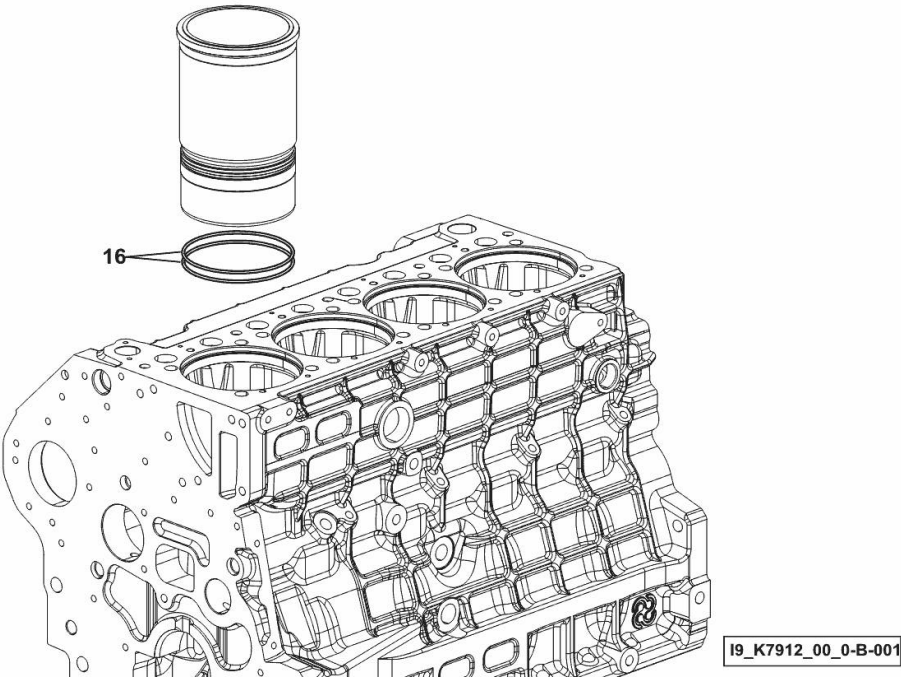

STRIKE 115.4 T4i -> ZKDAW10200TL10001

Section: B0 - ENGINE

Ref: B0.01.2 (1)

SIDE PLUG FOR CYLINDER BLOCK

Fig.	P/n	QTY	Name
------	-----	-----	------

Notes:
- FOR TYPES WITH PNEUMATIC BRAKE [STRIKE 115.4 T4i 2WD -> ZKDAW10100TL10001] - FOR TYPES WITH PNEUMATIC BRAKE [STRIKE 115.4 T4i 4WD -> ZKDAW10200TL10001]

12	2.1560.018.0	1	gasket 22.2 x 29
13	2.3120.102.0	1	plug

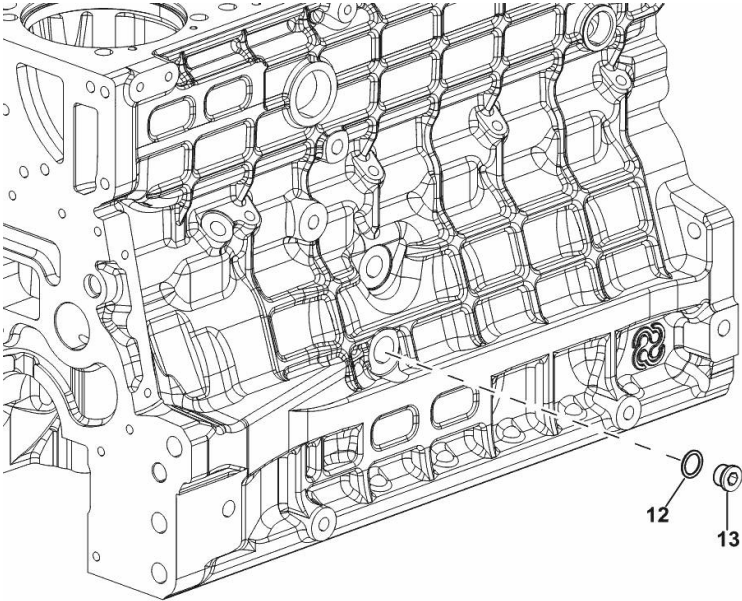

9_K8015_03_0-B-001

STRIKE 115.4 T4i -> ZKDAW10200TL10001

Section: B0 - ENGINE

Ref: B0.01.3 (1)

MONOBLOC ENGINE-GEARBOX CONNECTING FLANGE

Fig.	P/n	QTY	Name
------	-----	-----	------

Notes:

[STRIKE 115.4 T4i 2WD -> ZKDAW10100TL10001] [STRIKE 115.4 T4i 4WD -> ZKDAW10200TL10001]

1	2.1475.005.2	2	washer 14
2	2.0112.524.2	2	screw m 14 p.2 x 75
3	2.0112.624.2	2	screw m 16 p.2 x 75
4	2.1475.006.2	2	spring washer 16
6	2.0439.250.7	1	stud bolt m 12 / m 10 x 30
7	0.011.9294.0/10	1	bush
25	0.019.1488.0	1	flange
26	2.0112.511.2	8	screw m 14 p.2 x 30
27	2.1651.912.0	2	cylindrical plug 12x28
28	2.1651.917.0	1	cylindrical plug 12x40
29	2.0432.257.7	1	stud bolt m 12 p.1.75 - 1.25 x 30

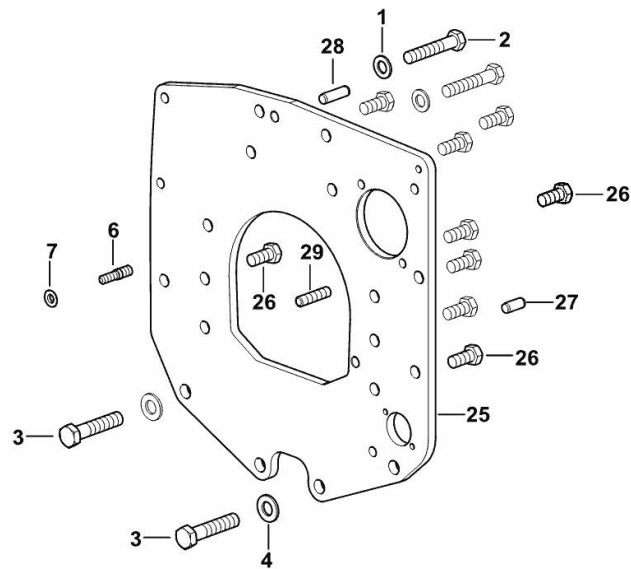

[9_K7411_01_0-A-001]

CRANKSHAFT PULLEY

Fig.	P/n	QTY	Name
------	-----	-----	------

Notes:

[STRIKE 115.4 T4i 2WD -> ZKDAW10100TL10001] [STRIKE 115.4 T4i 4WD -> ZKDAW10200TL10001]

1	0.019.9925.0	1	pulley
2	0.019.6668.0	1	flange
3	0.065.1256.0	2	ring 45x52
4	2.1579.865.0	1	spacer 45.2x51.8x10
5	2.0439.195.7	1	stud bolt m 20 p.1.5x80
6	2.1019.094.7	1	nut m 20 p.1.5
7	2.0112.320.2	6	screw m 10 p.1.5 x 55
8	2.1470.006.2	6	lock washer 10
9	2.1720.006.0	1	key 4x6.5
10	0.019.6413.0	1	gear wheel
11	2.1651.505.0	1	cylindrical plug 6x12

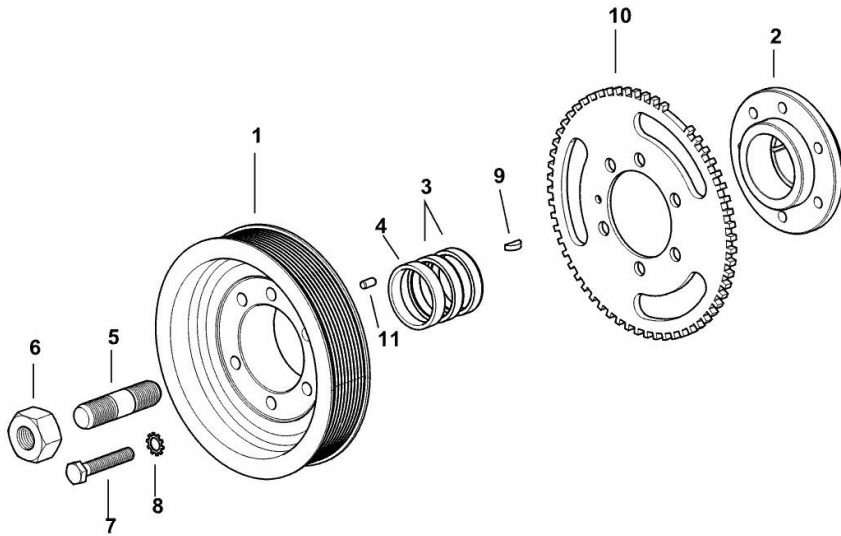

19_K7812_01_0-A-001

Buy Now



Our support email:

ebooklibonline@outlook.com