



Service Manual

MC/FC

Chassis, Mast & Options

EP16NT	ETB11-20011-up
EP18NT	ETB13-20011-up
EP20NT	ETB13-70001-up

FOREWORD

This service manual is a guide for servicing Cat® lift trucks. For your convenience the instructions are grouped by systems as a ready reference.

The long productive life of your lift trucks depend on regular and proper servicing. Servicing consistent with what you will learn by reading this service manual. Read the respective sections of this manual carefully and familiarize yourself with all of the components before attempting to start a test, repair or rebuild job.

The descriptions, illustrations and specifications contained in this manual are for trucks with serial numbers in effect at the time of printing. Cat lift trucks reserves the right to change specifications or design without notice and without incurring obligation.

Safety Related Signs

The following safety related signs are used in this service manual to emphasize important and critical instructions:



Indicates a potentially hazardous situation which, if not avoided, could result in death or serious injury.



Indicates a potentially hazardous situation which, if not avoided, may result in death or serious injury or damage to the machine.



Indicates a condition that can cause damage to, or shorten service life of, the machine.

HOW TO READ THIS MANUAL

Disassembly diagram (example)

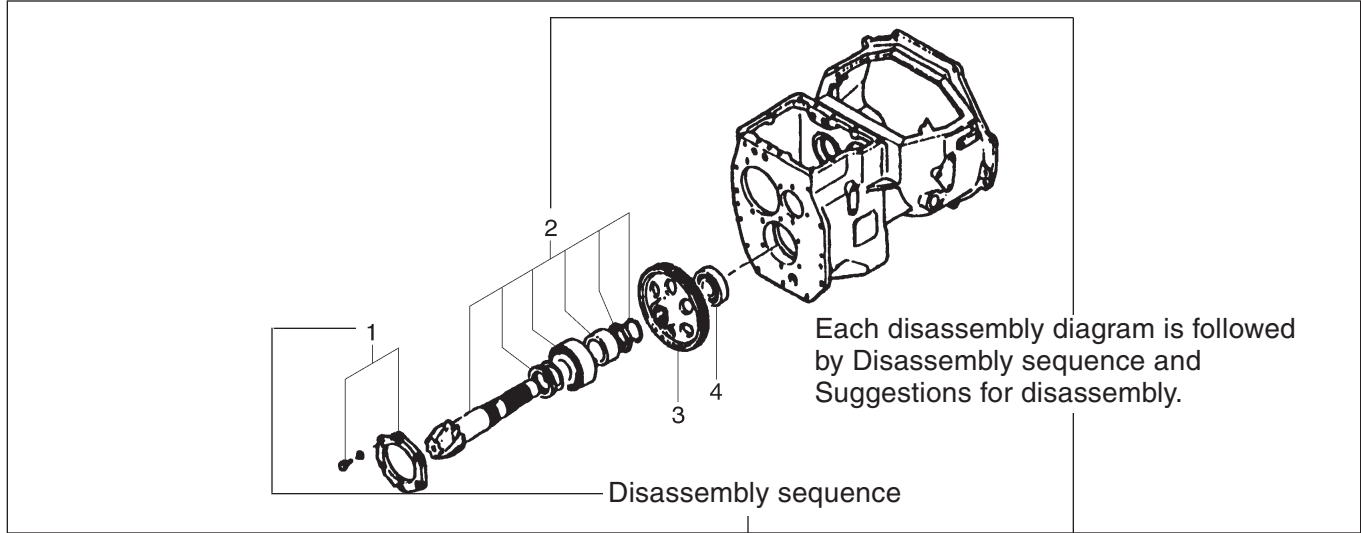

Sequence

1. Cover, Bolt, Washer (part name)
2. Output shaft (part name)

Suggestion for disassembly

(1) Output shaft removal

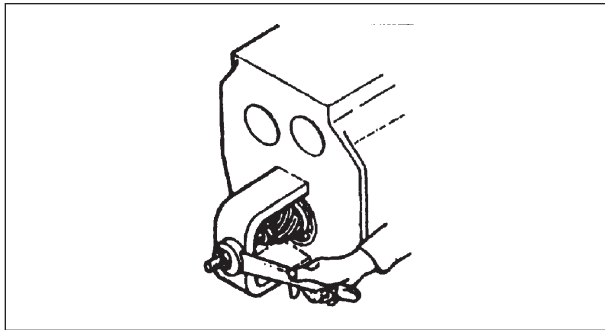

Unit: mm (in.)

Clearance between cylinder and piston	A	0.020 to 0.105 (0.00079 to 0.00413)
	B	0.15 (0.0059)

A: Standard value B: Repair or service limit

 **WARNING**

SAFETY

 **WARNING**

The proper and safe lubrication and maintenance for these lift trucks, recommended by Cat lift truck, are outlined in the OPERATION & MAINTENANCE MANUAL.

Improper performance of lubrication or maintenance procedures is dangerous and could result in injury or death. Read and understand the OPERATION & MAINTENANCE MANUAL before performing any lubrication or maintenance on these trucks.

The serviceman or mechanic may be unfamiliar with many of the systems on this truck. This makes it important to use caution when performing service work. A knowledge of the system and/or components is important before the removal or disassembly of any component.

Because of the size of some of the truck components, the serviceman or mechanic should check the weights noted in this Manual. Use proper lifting procedures when removing any components.

Following is a list of basic precautions that should always be observed.

1. Read and understand all warning plates and decals on the truck before operating, lubricating or repairing the product.
2. Always wear protective glasses and protective shoes when working around trucks. In particular, wear protective glasses when pounding on any part of the truck or its attachments with a hammer or sledge. Use welders gloves, hood/goggles, apron and other protective clothing appropriate to the welding job being performed. Do not wear loose-fitting or torn clothing. Remove all rings from fingers when working on machinery.
3. Do not work on any truck that is supported only by lift jacks or a hoist. Always use blocks or jack stands to support the truck before performing any disassembly.

 **WARNING**

Do not operate these trucks unless you have read and understand the instructions in the OPERATION & MAINTENANCE MANUAL. Improper truck operation is dangerous and could result in injury or death.

4. Lower the forks or other implements to the ground before performing any work on the truck. If this cannot be done, make sure the forks or other implements are blocked correctly to prevent them from dropping unexpectedly.
5. Use steps and grab handles (if applicable) when mounting or dismounting a truck. Clean any mud or debris from steps, walkways or work platforms before using. Always face truck when using steps, ladders and walkways. When it is not possible to use the designed access system, provide ladders, scaffolds, or work platforms to perform safe repair operations.
6. To avoid back injury, use a hoist when lifting components which weigh 23 kg (50 lb.) or more. Make sure all chains, hooks, slings, etc., are in good condition and are of the correct capacity. Be sure hooks are positioned correctly. Lifting eyes are not to be side loaded during a lifting operation.
7. To avoid burns, be alert for hot parts on trucks which have just been stopped and hot fluids in lines, tubes and compartments.
8. Be careful when removing cover plates. Gradually back off the last two bolts or nuts located at opposite ends of the cover or device and pry cover loose to relieve any spring or other pressure, before removing the last two bolts or nuts completely.
9. Be careful when removing filler caps, breathers and plugs on the truck. Hold a rag over the cap or plug to prevent being sprayed or splashed by liquids under pressure. The danger is even greater if the truck has just been stopped because fluids can be hot.

10. Always use tools that are in good condition and be sure you understand how to use them before performing any service work.
11. Reinstall all fasteners with same part number. Do not use a lesser quality fastener if replacements are necessary. Do not mix metric fasteners with standard nuts and bolts.
12. If possible, make all repairs with the truck parked on a level, hard surface. Block truck so it does not roll while working on or under truck.
13. Disconnect battery and discharge any capacitors (electric trucks) before starting to work on truck. Hang "Do not Operate" tag in the Operator's Compartment.
14. Repairs, which require welding, should be performed only with the benefit of the appropriate reference information and by personnel adequately trained and knowledgeable in welding procedures. Determine type of metal being welded and select correct welding procedure and electrodes, rods or wire to provide a weld metal strength equivalent at least to that of parent metal.
15. Do not damage wiring during removal operations. Reinstall the wiring so it is not damaged nor will it be damaged in operation by contacting sharp corners, or by rubbing against some object or hot surface. Do not connect wiring to a line containing fluid.
16. Be sure all protective devices including guards and shields are properly installed and functioning correctly before starting a repair. If a guard or shield must be removed to perform the repair work, use extra caution.
17. Always support the mast and carriage to keep carriage or attachments raised when maintenance or repair work is performed, which requires the mast in the raised position.
18. Loose or damaged fuel, lubricant and hydraulic lines, tubes and hoses can cause fires. Do not bend or strike high pressure lines or install ones which have been bent or damaged. Inspect lines, tubes and hoses carefully. Do not check for leaks with your hands. Pin hole (very small) leaks can result in a high velocity oil stream that will be invisible close to the hose. This oil can penetrate the skin and cause personal injury. Use cardboard or paper to locate pin hole leaks.
19. Tighten connections to the correct torque. Make sure that all heat shields, clamps and guards are installed correctly to avoid excessive heat, vibration or rubbing against other parts during operation. Shields that protect against oil spray onto hot exhaust components in event of a line, tube or seal failure, must be installed correctly.
20. Relieve all pressure in air, oil or water systems before any lines, fittings or related items are disconnected or removed. Always make sure all raised components are blocked correctly and be alert for possible pressure when disconnecting any device from a system that utilizes pressure.
21. Do not operate a truck if any rotating part is damaged or contacts any other part during operation. Any high speed rotating component that has been damaged or altered should be checked for balance before reusing.

GROUP INDEX

GROUP INDEX	Items	
GENERAL INFORMATION	Serial number locations, Dimensions, Technical data	1
VEHICLE ELECTRICAL COMPONENTS	Console box, Key switch, Lamp specification chart	2
POWER TRAIN	Procedure and suggestions for removal and installation	3
TRANSFER UNITS	Procedures and suggestions for disassembly and reassembly	4
REAR AXLE	Rear axle, Rear wheels	5
BRAKE SYSTEM	Caliper, Brake pedal, Master cylinder	6
STEERING SYSTEM	Steering control valve	7
HYDRAULIC SYSTEM	Tank, Pump, Control valve, Lift and tilt cylinders, Flow regulator valve, Down safety valve	8
MASTS AND FORKS	Simplex mast, Duplex mast, Triplex mast	9
SERVICE DATA	Inspection standards, Periodic replacement of parts, Lubrication standards, Main component weight, Tightening torque for standard bolts and nuts, Special tools	10
OPTIONS	Rearview mirror kit, Backup buzzer kit, Working lamp kit, Tire kit	11

GENERAL INFORMATION

Vehicle Exterior	1 – 1
Models	1 – 1
Serial Number Locations	1 – 2
Chassis and Mast Model Identification	1 – 3
Dimensions	1 – 4
Technical Data	1 – 5

Vehicle Exterior

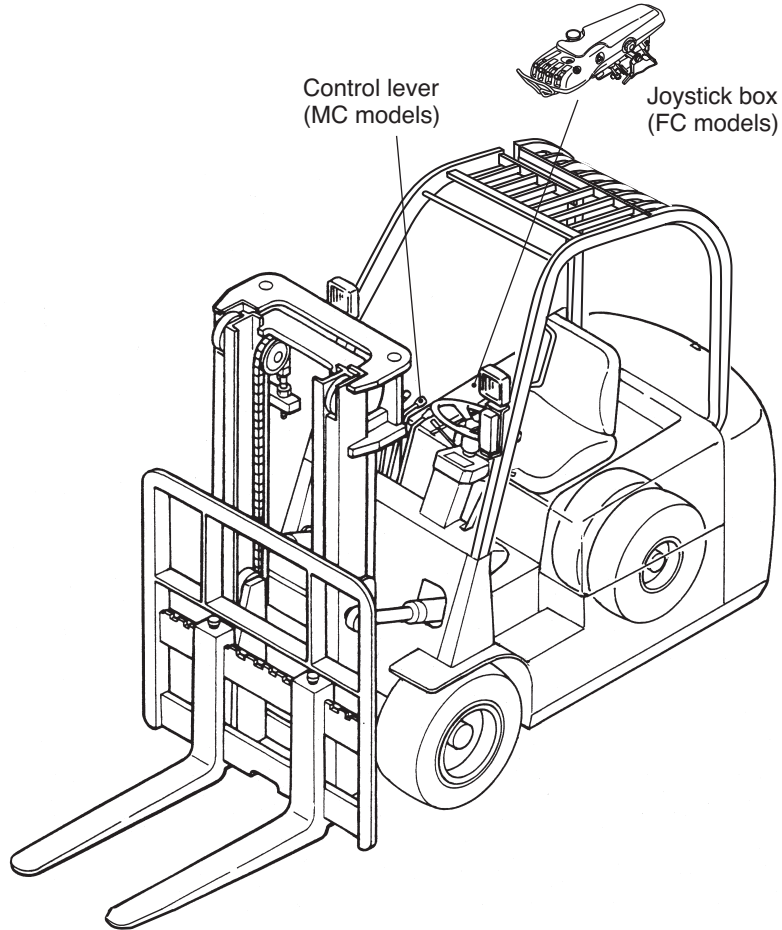

211128

Models

This manual applies to EP16NT, EP18NT and EP20NT.

Truck Model	Serial Number
EP16NT	ETB11-20011-up (48V)
EP18NT	ETB13-20011-up (48V)
EP20NT	ETB13-70001-up (48V)

Serial Number Locations

Mast number

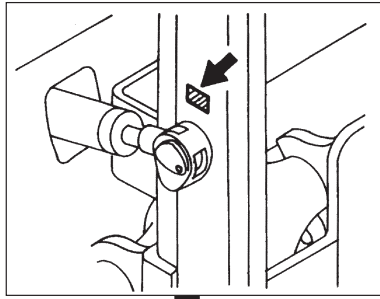

Chassis number

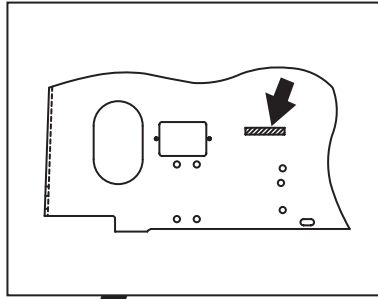

Nameplate

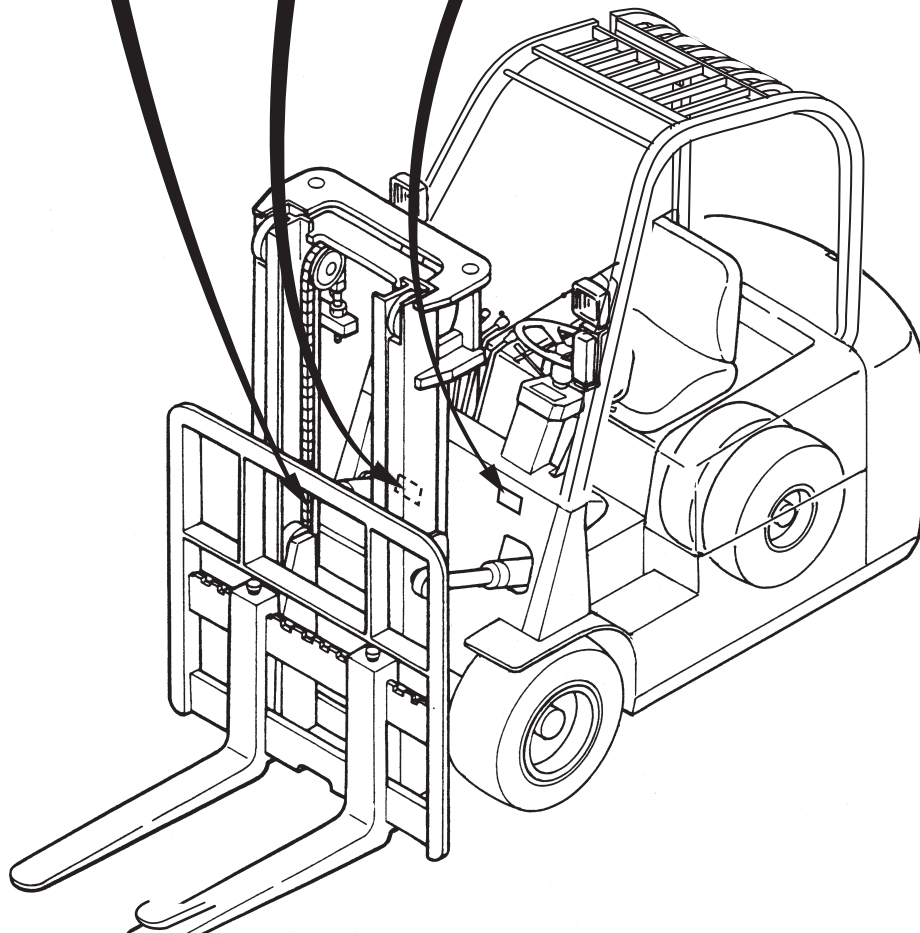
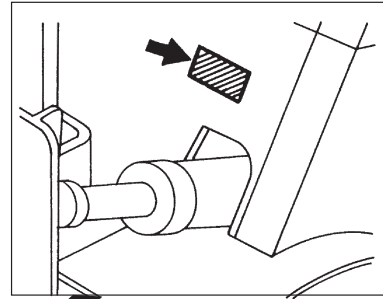

Chassis and Mast Model Identification

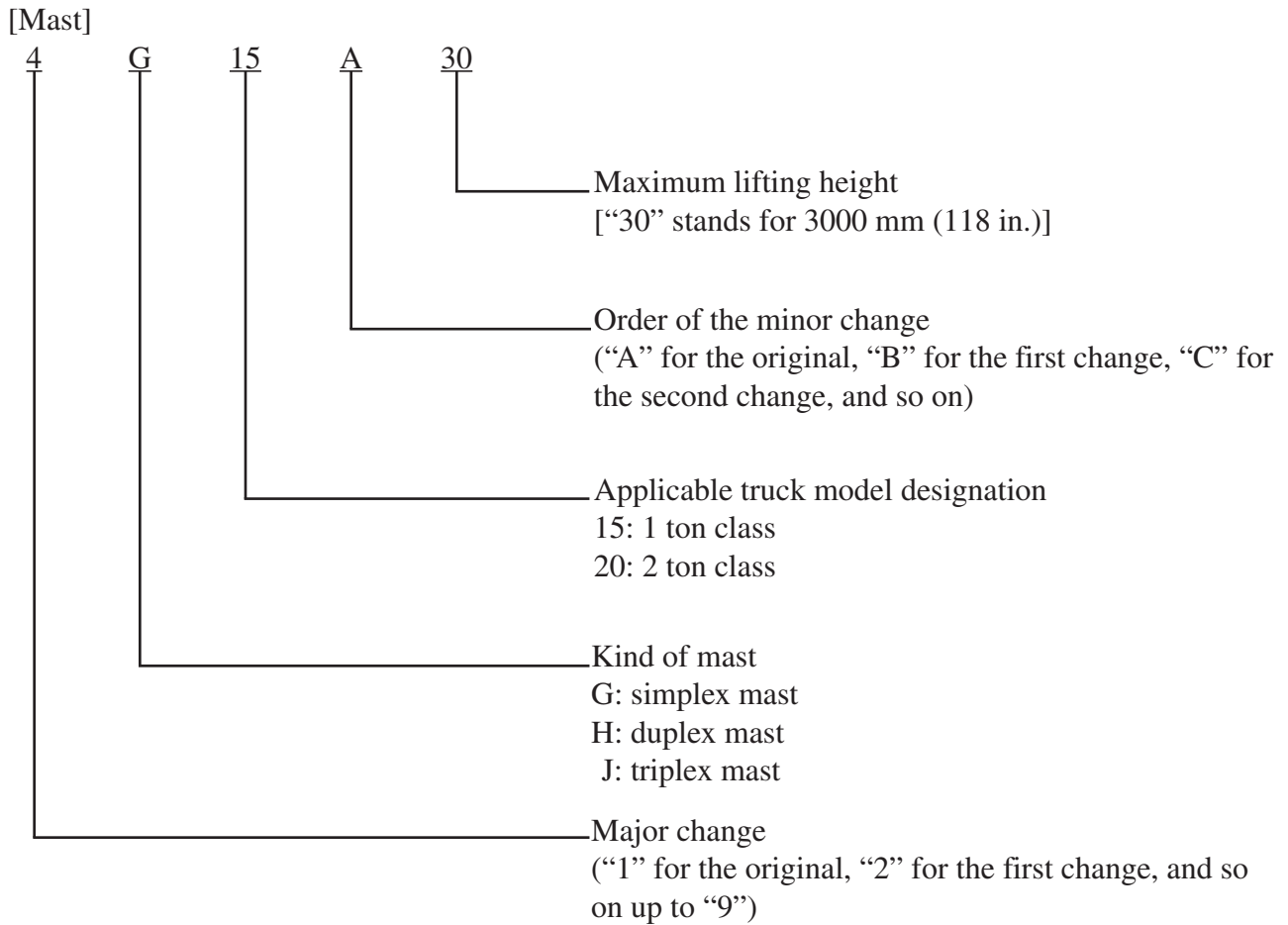
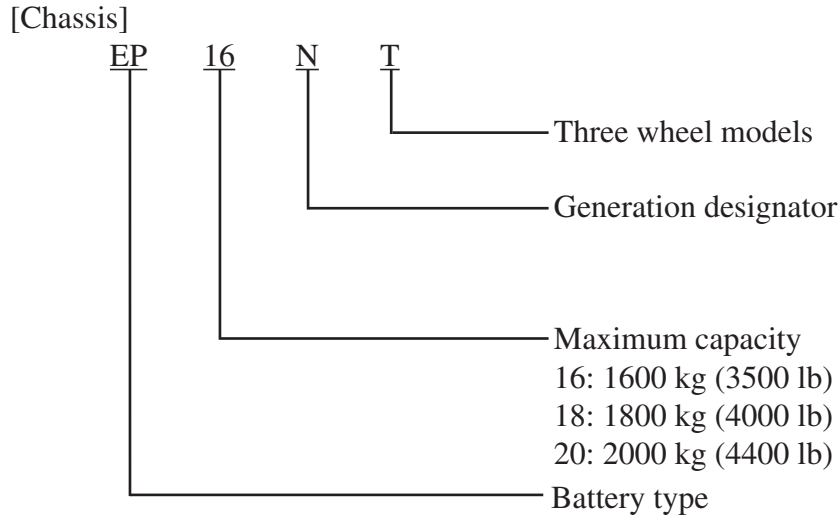

Dimensions

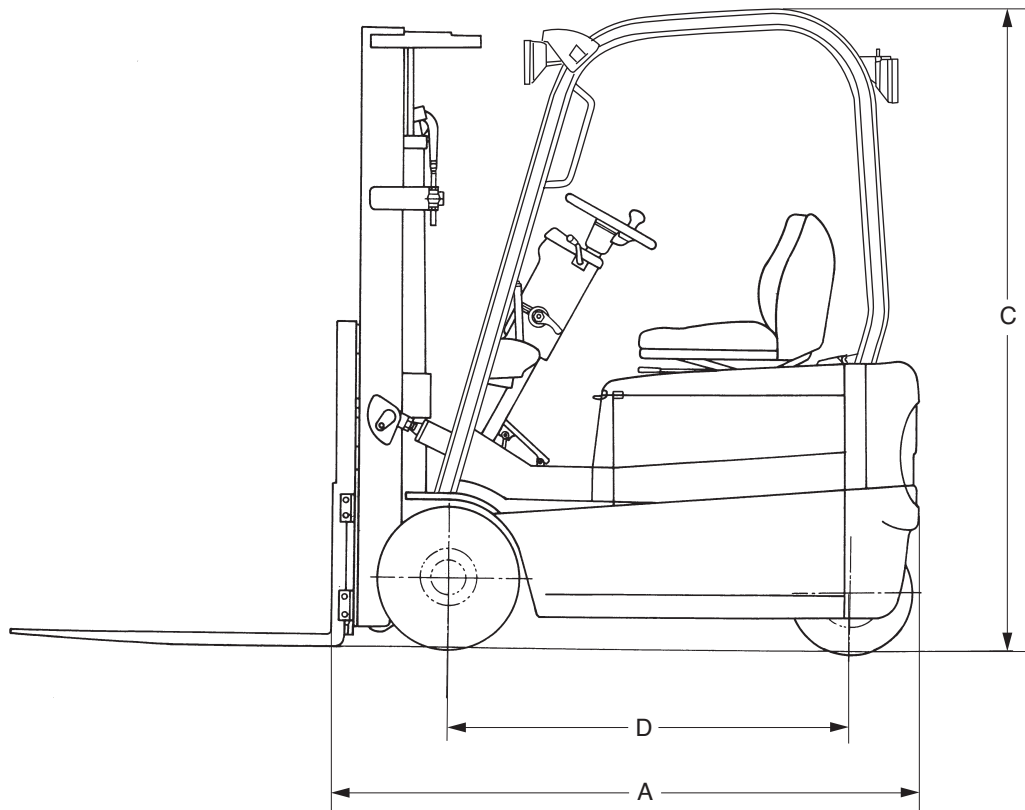
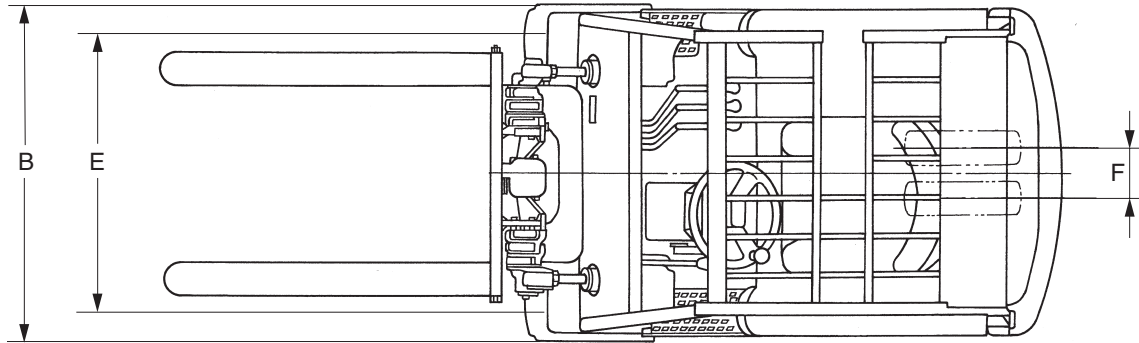

Technical Data

Truck Models			EP16NT	EP18NT	EP20NT
Class			1.6 ton	1.8 ton	2.0 ton
Load Capacity/Load Center		N (kgf)/mm [lbf/in.]	15690 (1600)/500 [3500/20]	17650 (1800)/500 [4000/20]	19610 (2000)/500 [4400/20]
Truck size	Length to Fork Face	A mm (in.)	1893 (74.5)	1996 (78.6)	2032 (80.0)
	Width	B mm (in.)	1070 (42.1)	1070 (42.1)	1130 (44.5)
	Height of Overhead Guard	C mm (in.)	2048 (80.6)	2048 (80.6)	2048 (80.6)
Wheelbase		D mm (in.)	1307 (51.5)	1410 (55.5)	1410 (55.5)
Service Weight (including battery)		kg (lb)	3090 (6812)	3290 (7253)	3520 (7760)
Tread Front/Rear		E/F mm (in.)	913/170 (35.9/6.7)	913/170 (35.9/6.7)	935/170 (36.8/6.7)
Tires Number Front/Rear			2/2	2/2	2/2
Tires Size	Front		18 × 7-8	18 × 7-8	200/50-10
	Rear		15 × 4.5-8	15 × 4.5-8	140/55-9
Turning Radius		mm (in.)	1517 (59.7)	1620 (63.8)	1645 (64.8)
Travel Speeds Unloaded/Loaded		km/h (mph)	17/17 (10.6/10.6)	17/17 (10.6/10.6)	17/17 (10.6/10.6)
Gradeability Loaded [5 min., at 1.6 km/h (1.0 mph)]		%	27	25	23
Lift Speeds Unloaded/Loaded		m (in.)/sec	0.60/0.50 (23.6/19.7)	0.60/0.44 (23.6/17.3)	0.60/0.40 (23.6/15.7)
Lowering Speed Unloaded/Loaded		m (in.)/sec	0.50/0.52 (19.7/20.5)	0.50/0.52 (19.7/20.5)	0.50/0.52 (19.7/20.5)
Battery Voltage		V	48	48	48
Battery Rated Capacity (5 hrs.) MAX		Ah	600	720	720
Battery Compartment Length × Width × Height		mm (in.)	521 × 1006 × 650 (20.5 × 39.6 × 25.6)	624 × 1006 × 650 (24.6 × 39.6 × 25.6)	624 × 1006 × 650 (24.6 × 39.6 × 25.6)
Tilt Angle (forwards-backwards)			6°-7°	6°-7°	6°-7°
Traction Motor, 60 min short duty		kW	2 × 6.3	2 × 6.3	2 × 6.3
Hydraulic Motor		kW	14	14	14
Traction Motor Control Method			MOSFET	MOSFET	MOSFET
Hydraulic Motor Control Method			MOSFET	MOSFET	MOSFET

VEHICLE ELECTRICAL COMPONENTS

Console Box	2 – 1
Functions of Central Vehicle Monitor System	2 – 1
Electrical Components in Console Box	2 – 5
Disassembly and Reassembly	2 – 6
Direction Lever	2 – 7
Accelerator Control	2 – 8
Key Switch	2 – 9
Lighting Switch	2 – 9
Fuses	2 – 10
Lamp Specification Chart	2 – 10
Troubleshooting of Lighting and Horn Systems	2 – 11
Joystick Box	2 – 12

Console Box

- 1 Central vehicle monitoring system (CVMS)
- 2 Mode selector button
- 3 Steering tilt lever
- 4 Key switch
- 5 Lighting switch
- 6 Mode check button

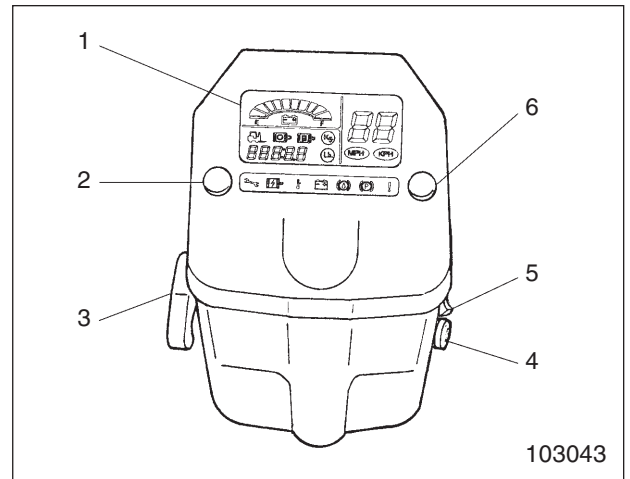

NOTE

For setting the clock and selection of KPH or MPH, refer to “Selection of KPH or MPH” and “Setting the clock”.

Functions of Central Vehicle Monitor System (CVMS)

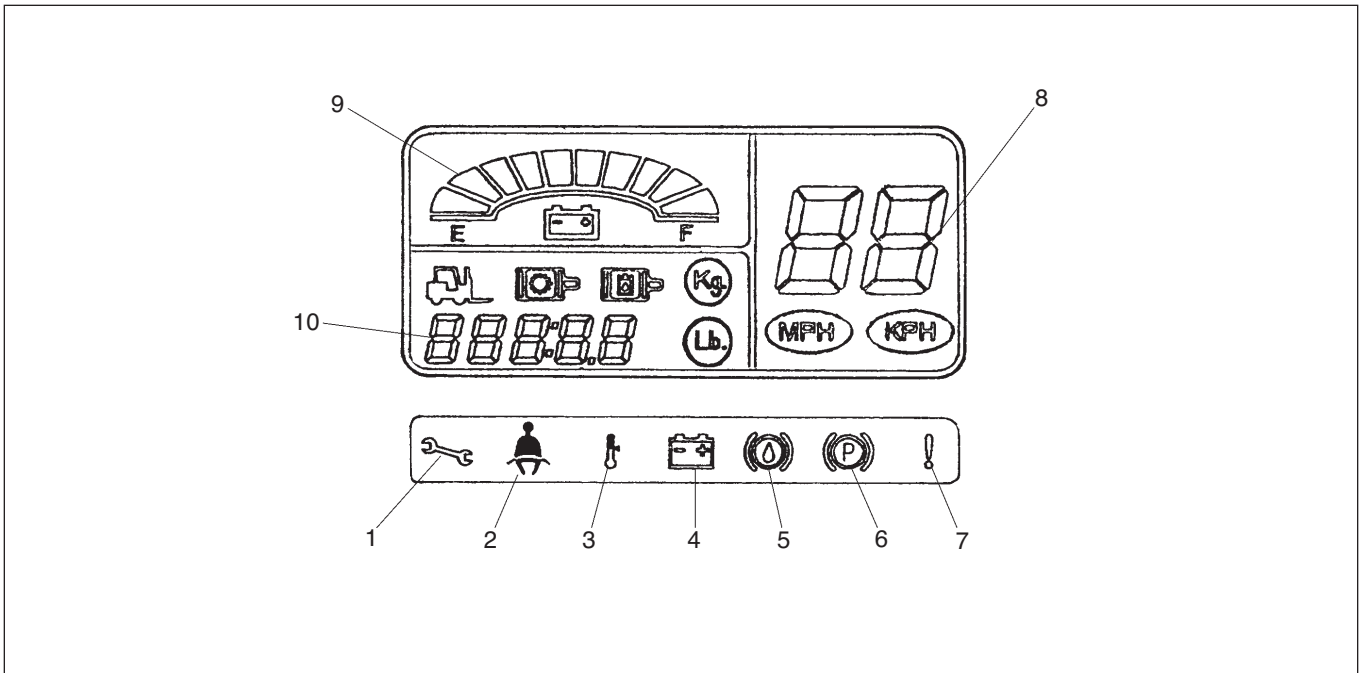

Operations

211131

No.	Monitor name	When OFF	When ON or flashing	Remarks
1	Service indicator	Starts flashing 20 hours before set time. Remains ON when set time is reached.		
2	Seat belt warning light	Seat belt is fastened.	Seat belt is not fastened when operator sits on seat (seat switch is turned on).	

VEHICLE ELECTRICAL COMPONENTS

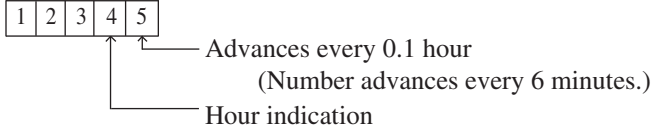
No.	Monitor name	When OFF	When ON or flashing	Remarks
3	Controller/motor overheat indicator	Controller, drive motors and pump motor in normal temperature	Overheating	Overheating causes a significant output loss. When component temperature returns to normal levels, output power returns.
4	Remaining battery charge warning light	Normal battery condition	Flashing indicates battery needs to be recharged soon. ON indicates battery needs to be recharged and lifting function inoperable.	
5	Brake fluid level indicator	Normal fluid level	Low fluid level	
6	Parking brake warning light	Parking brake disengaged	Parking brake disengaged	
7	Malfunction lamp	Normal	Vehicle malfunction	
8	Speedometer	KPH, MPH		
	Error indicator			
9	Battery discharge indicator	When no bars show, vehicle is drivable but lifting function is inoperable.		Indicates remaining battery power.
10	Hour meter	 <p> 1 2 3 4 5 </p> <p> ——— Advances every 0.1 hour (Number advances every 6 minutes.) </p> <p> ——— Hour indication </p>		

Thank you so much for reading.
Please click the “Buy Now!”
button below to download the
complete manual.



After you pay.

You can download the most
perfect and complete manual in
the world immediately.

Our support email:

ebooklibonline@outlook.com