

Service Manual

LOADALL

PUBLISHED BY THE
TECHNICAL PUBLICATIONS DEPARTMENT
OF JCB SERVICE; ©

WATERLOO PARK, UTTOXETER,
ST14 5PA, ENGLAND
Tel. 01889 - 590312
PRINTED IN ENGLAND

Publication No. 9803/3610U-4

General Information	1
Care & Safety	2
Routine Maintenance	3
Attachments	A
Body & Framework	B
Electrics	C
Controls	D
Hydraulics	E
Transmission	F
Brakes	G
Steering	H
Engine	K

Introduction

This publication is designed for the benefit of JCB Distributor Service Engineers who are receiving, or have received, training by JCB Technical Training Department.

These personnel should have a sound knowledge of workshop practice, safety procedures, and general techniques associated with the maintenance and repair of hydraulic earthmoving equipment.

Renewal of oil seals, gaskets, etc., and any component showing obvious signs of wear or damage is expected as a matter of course. It is expected that components will be cleaned and lubricated where appropriate, and that any opened hose or pipe connections will be blanked to prevent excessive loss of hydraulic fluid and ingress of dirt. Finally, please remember above all else **SAFETY MUST COME FIRST!**

The manual is compiled in sections, the first three are numbered and contain information as follows:

- 1** = **General Information** - includes torque settings and service tools.
- 2** = **Care & Safety** - includes warnings and cautions pertinent to aspects of workshop procedures etc.
- 3** = **Routine Maintenance** - includes service schedules and recommended lubricants for all the machine.

The remaining sections are alphabetically coded and deal with Dismantling, Overhaul etc. of specific components, for example:

- A** = **Attachments**
- B** = **Body & Framework** ...etc.

The page numbering in each alphabetically coded section is not continuous. This allows for the insertion of new items in later issues of the manual.

Section contents, technical data, circuit descriptions, operation descriptions etc are inserted at the beginning of each alphabetically coded section.

READ the section contents to locate machine types, machine type identification **IS NOT** listed on individual pages.

All sections are listed on the front cover; tabbed divider cards align directly with individual sections on the front cover for rapid reference.

Where a torque setting is given as a single figure it may be varied by plus or minus 3%. Torque figures indicated are for dry threads, hence for lubricated threads may be reduced by one third.

'Left Hand' and 'Right Hand' are as viewed from the rear of the machine facing forwards.

This Service Manual covers the following machines:

- 504B - from Machine Serial Number 277001
- *526 - from Machine Serial Number 279289

Contents	Page No.
Identification	1 - 1
Torque Settings	2 - 1
Service Tools	
- Numerical List	3 - 1
* - Section B	3 - 3
- Section C	4 - 1
- Section E	5 - 1
- Section F	6 - 1
- Section H	7 - 1
- Section K	7 - 1
Sealing and Retaining Compounds	8 - 1

Identification Plate

Your machine has an identification plate **V** mounted as shown. The serial numbers of the machine and its major units are stamped on the plate.

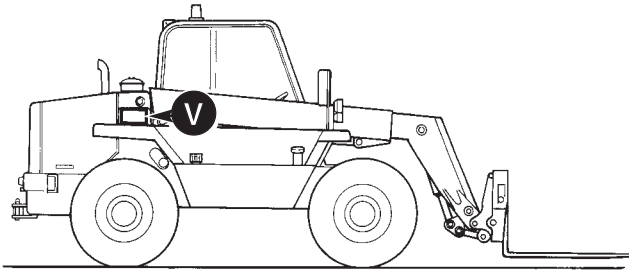

S195340

Unit Identification

The engine serial number is stamped on a label **W** which is fastened to the right side of the cylinder block, near the fuel filter.

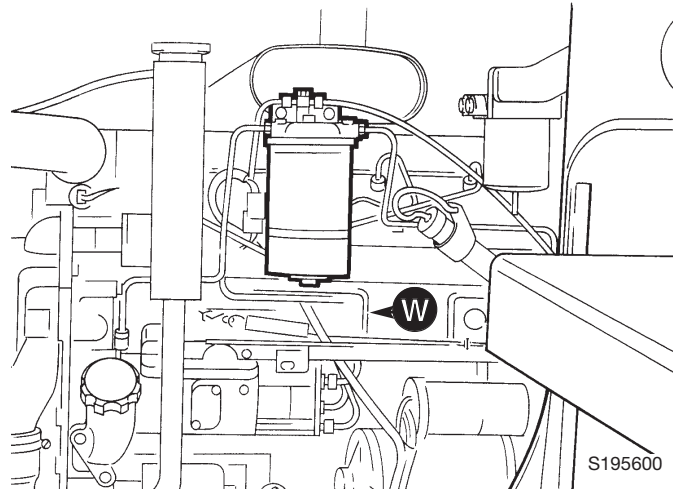

S195600

Explanation of Vehicle Identification Number (VIN)

SLP504BRE0277001

A B C D E

A	World Manufacturer Identification	SLP = JCB
* B	Machine Model	504B
C	Year of Manufacture	S
	P = 1993	V = 1997
	R = 1994	W = 1998
	S = 1995	X = 1999
	T = 1996	Y = 2000
D	Manufacturing Location	E = England
E	Machine Serial Number	0277001

Machine Model Explanation

504B
F G

- F** 500 Series machine range
G 4,000 lbs lift capacity

The serial number of each major unit is also stamped on the unit itself. If a major unit is replaced by a new one, the serial number on the identification plate will be wrong. Either stamp the new number of the unit on the identification plate, or simply stamp out the old number. This will prevent the wrong unit number being quoted when replacement parts are ordered.

The machine and engine serial numbers can help identify exactly the type of equipment you have.

Typical Engine Identification Number

AA 50261 U 500405 P
A B C D E

- A** Engine Type
AA = 4 cylinder naturally aspirated
AB = 4 cylinder turbo
- B** Build Number
- C** Country of Origin
- D** Engine Sequence Number
- E** Year of Manufacture

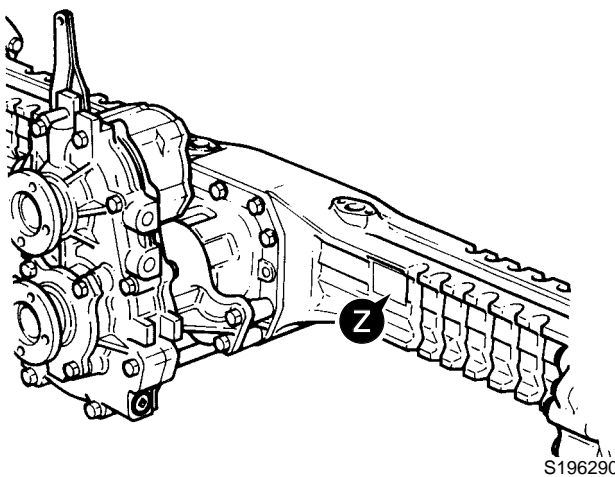
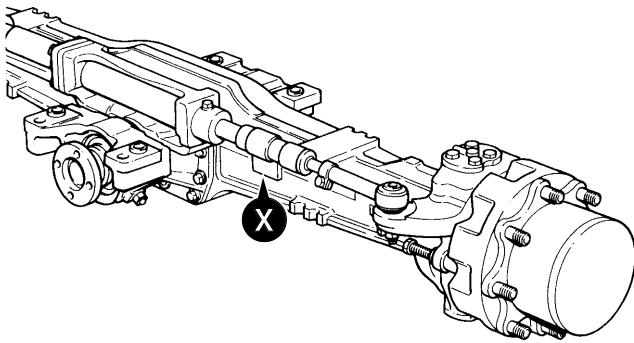
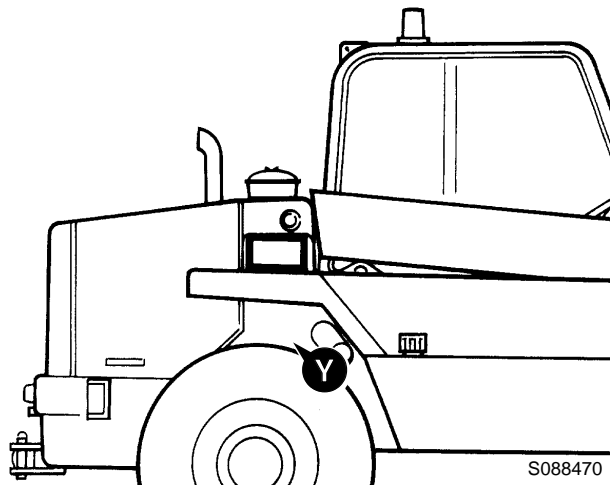

The Syncro Shuttle serial number is stamped on label Y as shown.

The rear axle serial number is stamped on plate X as shown.
The front axle serial number is stamped on plate Z as shown.

Torque Settings

Use only where no torque setting is specified in the text. Values are for dry threads and may be within three per cent of the figures stated. For lubricated threads the values should be REDUCED by one third.

UNF Grade 'S' Bolts

Bolt Size		Hexagon (A/F)		Torque Settings		
in	(mm)	in	Nm	kgf m	lbf ft	
1/4	(6.3)	7/16	14	1.4	10	
5/16	(7.9)	1/2	28	2.8	20	
3/8	(9.5)	9/16	49	5.0	36	
7/16	(11.1)	5/8	78	8.0	58	
1/2	(12.7)	3/4	117	12.0	87	
9/16	(14.3)	13/16	170	17.3	125	
5/8	(15.9)	15/16	238	24.3	175	
3/4	(19.0)	1 1/8	407	41.5	300	
7/8	(22.2)	*1 5/16	650	66.3	480	
1	(25.4)	1 1/2	970	99.0	715	
1 1/4	(31.7)	1 7/8	1940	198.0	1430	
1 1/2	(38.1)	2 1/4	3390	345.0	2500	

Metric Grade 8.8 Bolts

Bolt Size		Hexagon (A/F)		Torque Settings		
	(mm)	mm	Nm	kgf m	lbf ft	
M5	(5)	8	7	0.7	5	
M6	(6)	10	12	1.2	9	
M8	(8)	13	28	3.0	21	
M10	(10)	17	56	5.7	42	
M12	(12)	19	98	10	72	
M16	(16)	24	244	25	180	
M20	(20)	30	476	48	352	
M24	(24)	36	822	84	607	
M30	(30)	46	1633	166	1205	
M36	(36)	55	2854	291	2105	

Rivet Nut Bolts/Screws

Bolt Size		Torque Settings (for steel rivet nuts)		
	(mm)	Nm	kgf m	lbf ft
M3	(3)	1.2	0.12	0.9
M4	(4)	3.0	0.3	2.0
M5	(5)	6.0	0.6	4.5
M6	(6)	10.0	1.0	7.5
M8	(8)	24.0	2.5	18.0
M10	(10)	48.0	4.9	35.5
M12	(12)	82.0	8.4	60.5

Note: All bolts used on JCB machines are high tensile and must not be replaced by bolts of a lesser tensile specification.

Service Tools

Numerical List		Page No	Numerical List		Page No
1406/0011	Bonded Washer	5-1	892/00260	1 ¹ / ₄ " BSP Test Point	5-3
1406/0014	Bonded Washer	5-1	892/00261	5 ⁵ / ₈ " UNF Test Point	5-3
1406/0018	Bonded Washer	5-1	892/00262	1 ¹ / ₄ " M BSP 1 ¹ / ₄ " F BSP	5-1
1406/0021	Bonded Washer	5-1	892/00263	5 ⁵ / ₈ " M BSP 5 ⁵ / ₈ " F BSP	5-1
1406/0029	Bonded Washer	5-1	892/00264	3 ³ / ₄ " M BSP 3 ³ / ₄ " F BSP	5-1
1604/0003	Adapter	5-3	892/00265	1" M BSP 1" F BSP	5-1
1604/0004	Adapter	5-3	892/00268	Flow Monitoring Unit	5-1
1604/0006	Adapter	5-1	892/00269	Sensor Head	5-1
1606/0003	Adapter	5-3	892/00270	Load Valve	5-1
1606/0004	Adapter	5-3	892/00271	Adapter	5-1
1606/0007	Adapter	5-3	892/00272	Adapter	5-1
1606/0008	Adapter	5-3	892/00274	Adapter	5-3
1606/0009	Adapter	5-3	892/00275	Adapter	5-1
1606/0012	Adapter	5-3	892/00276	Adapter	5-1
1606/0014	Adapter	5-3	892/00277	Adapter	5-1
1606/0015	Adapter	5-3	* 892/00279	Pressure Gauge 0-400 bar (0-6000 lbf/in ²)	5-1
1606/0017	Adapter	5-3	* 892/00280	Pressure Gauge 0-600 bar (0-9000 lbf/in ²)	5-1
1612/0006	Adapter	5-1	892/00282	Shunt	4-1
816/00189	Blanking Cap	5-2	892/00283	Tool Kit Case	4-1
816/00190	Blanking Cap	5-2	892/00284	Digital Tachometer	4-1
816/00193	Blanking Cap	5-2	892/00285	Hyd. Oil Temperature Probe	4-1
816/00196	Blanking Cap	5-2	892/00286	Surface Temperature Probe	4-1
816/00197	Blanking Cap	5-2	892/00295	End Float Setting Tool	6-1
816/00294	Blanking Cap	5-2	892/00298	Fluke Meter	4-1
816/15118	Pressure Test Adapter	5-3	892/00301	Flow Test Adapter	6-1
816/20008	Adapter	5-1	892/00302	Flow Test Adapter	6-1
816/55038	Pressure Test Adapter	5-1	892/00304	Flow Test Adapter	6-1
816/55040	Pressure Test Adapter	5-1	892/00333	Heavy Duty Socket	6-2
816/50043	'T' Adapter	5-2	892/00334	Seal Fitting Tool	5-4
892/00039	Spool Clamp	5-2	* 892/00346	Pressure Gauge 0-70 bar (0-1000 lbf/in ²)	6-1
892/00041	De-glazing Tool	7-1	892/00706	Test Probe	5-3
892/00047	'T' Adapter	5-2	892/00817	Heavy Duty Socket	6-2
892/00048	'T' Adapter	5-2	892/00818	Heavy Duty Socket	6-2
892/00049	'T' Adapter	5-2	892/00819	Heavy Duty Socket	6-2
892/00051	'T' Adapter	5-2	892/00842	Glass Lifter	3-3
892/00055	Blanking Plug	5-2	892/00843	Glass Stand	3-3
892/00056	Blanking Plug	5-2	892/00844	Long Knife	3-4
892/00057	Blanking Plug	5-2	892/00846	Glass Extractor (Handles)	3-4
892/00058	Blanking Plug	5-2	892/00847	Nylon Spatula	3-3
892/00059	Blanking Plug	5-2	892/00848	Wire Starter	3-4
892/00060	Blanking Plug	5-2	892/00849	Braided Cutting Wire	3-4
892/00071	Adapter	5-3	892/00891	Seal Fitting Adapter	6-3
892/00074	Female Connector	5-2	892/00893	Torque Converter Alignment Bar	6-2
892/00075	Female Connector	5-2	892/00902	Spanner, Track Rod End	6-3
892/00076	Female Connector	5-2	892/00903	Spanner, Differential	6-3
892/00077	Female Connector	5-2	892/00904	Spanner, Differential	6-3
892/00121	Discharge Tester	4-1	892/00905	SLI Test Box	4-1
892/00137	Micro-Bore Hose	5-3	892/00906	Seal Fitting Adapter	6-3
892/00179	Bearing Press	6-1	892/00916	Spring Compression Tool	6-4
892/00180	Seal Fitting Tool	7-1	892/00918†	Setting Tool Kit	6-5
892/00181	Plastic Boss	7-1	892/00920	Flow Test Adaptor	6-1
892/00223	Hand Pump	5-3	892/00923	Test Block for A.R.V.	5-3
892/00224	Impulse Extractor	6-2	892/00943	Hand Held Test Unit	4-3
892/00225	Adapter - Impulse Extractor	6-2	892/00964	Test Point (1/8 BSP) PS700	6-4
* 892/00254	Hose	5-1	892/00965	Test Point (3/8 BSP) PS700	6-4
892/00255	1 ¹ / ₄ " BSP Test Point	5-3	892/00966	Test Point (1/4 BSP) SS400, SS600	6-4
892/00256	3 ³ / ₈ " BSP Test Point	5-3	921/52600†	Spacer Kit	6-5
892/00257	1 ¹ / ₂ " BSP Test Point	5-3	926/15500	Rubber Spacer Blocks	3-3
892/00258	5 ⁵ / ₈ " BSP Test Point	5-3	992/02800	ARV Extractor	5-2
892/00259	1" BSP Test Point	5-3	992/04000	Torque Multiplier	6-2

* Service Tools (cont'd)

Numerical List		Page No	Numerical List		Page No
992/04800	Drive Coupling Spanner	6-1	Replacement items for kit no. 993/70100		
992/07000	Ram End Cap Peg Spanner	5-3	993/70101	Base Plate and Bolts	6-8
992/07603	Replacer- Bearing Cup	6-1	993/70104	Mainshaft Pillar	6-8
992/07608	Bearing Adapter	6-1	993/70106	Layshaft/Reverser Pillar	6-8
992/07609	Bearing Adapter	6-1	993/70112	Input Shaft Pillar	6-8
992/07610	Bearing Adapter	6-1	993/70120	Setting Assembly	6-8
992/07611	Bearing Adapter	6-1	993/70130	Mainshaft Adapter	6-8
992/07612	Bearing Adapter	6-1	993/70140	Setting Assembly	6-8
992/07613	Bearing Adapter	6-1	993/70160	Yoke Assembly	6-8
992/09500	Spanner	5-2			
992/09700	Spanner	5-2	Note: To maintain a complete kit, order a replacement spacer for the one used.		
992/10100	Spool Clamp	5-2			
992/10900	Test Harness for SLI	4-1	† Identifies items required for all JCB Gearboxes from September 1996, when solid spacers replaced collapsible spacers.		
992/12800	Cut-Out Knife	3-4			
992/12801	'L' Blades	3-4			
993/59300	2/4 Wheel Pressure Tester & Clamp	6-2			
993/70100	Powershift Endfloat Checking Kit	6-8			
993/70111	Breakback Torque Wrench	6-5			
993/78200	Mainshaft Airline Adaptor	6-4	Ram Seal Protection Sleeves		5 - 4
993/99412	Adaptor Harness	4-1			
The following parts are replacement items for kits and would normally be included in the kit numbers above.			892/01016	For 25 mm Rod Diameter	
Replacement item for kit no. 892/00180			892/01017	For 30 mm Rod Diameter	
892/00181	Replacement Boss	7-1	892/01018	For 40 mm Rod Diameter	
Replacement items for kit no. 892/00253			892/01019	For 50 mm Rod Diameter	
892/00201	Replacement Gauge	5-1	892/01020	For 50 mm Rod Diameter (slew ram)	
892/00202	Replacement Gauge	5-1	892/01021	For 60 mm Rod Diameter	
892/00203	Replacement Gauge	5-1	892/01022	For 60 mm Rod Diameter (slew ram)	
892/00254	Replacement Hose	5-1	892/01023	For 65 mm Rod Diameter	
Replacement items for spacer kit no. 921/52600			892/01024	For 70 mm Rod Diameter	
921/52601	Spacer 12.75 mm	6-5	892/01025	For 75 mm Rod Diameter	
921/52602	Spacer 12.80 mm	6-5	892/01026	For 80 mm Rod Diameter	
921/52603	Spacer 12.85 mm	6-5			
921/52604	Spacer 12.90 mm	6-5	892/01027	Piston Seal Assembly Tool	
921/52605	Spacer 12.95 mm	6-5			
921/52606	Spacer 13.00 mm	6-5			
921/52607	Spacer 13.05 mm	6-5			
921/52608	Spacer 13.10 mm	6-5			
921/52609	Spacer 13.15 mm	6-5			
921/52610	Spacer 13.20 mm	6-5			
921/52611	Spacer 13.25 mm	6-5			
921/52612	Spacer 13.30 mm	6-5			
921/52613	Spacer 13.35 mm	6-5			
921/52614	Spacer 13.40 mm	6-5			
921/52615	Spacer 13.45 mm	6-5			
921/52616	Spacer 13.50 mm	6-5			
921/52617	Spacer 13.55 mm	6-5			
921/52618	Spacer 13.60 mm	6-5			
921/52619	Spacer 13.65 mm	6-5			
921/52620	Spacer 13.70 mm	6-5			
921/52621	Spacer 13.75 mm	6-5			
921/52622	Spacer 13.80 mm	6-5			
921/52623	Spacer 13.85 mm	6-5			
921/52624	Spacer 13.90 mm	6-5			
921/52625	Spacer 13.95 mm	6-5			
921/52626	Spacer 14.00 mm	6-5			

Service Tools

Section B - Body and Framework

826/01176	M6 x 16mm Rivet Nut
826/01106	M6 x 19mm Rivet Nut
826/01177	M8 x 18mm Rivet Nut
826/01176	M10 x 23mm Rivet Nut
826/01333	M10 x 26mm Rivet Nut

Installation Tool Available from:
 Bollhoff Fastenings Ltd.
 Midacre
 The Willenhall Estate
 Rose Hill
 Willenhall
 West Midlands, WV13 2JW

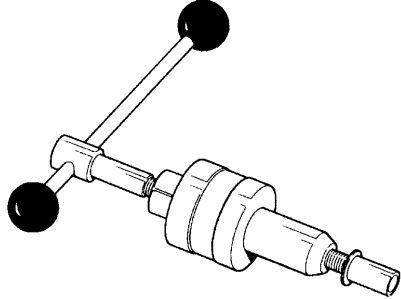

S150970

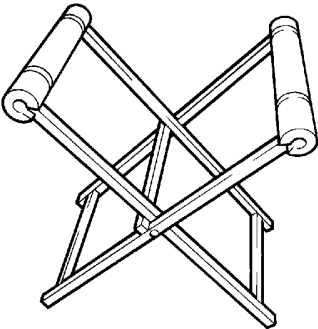

Folding Stand for Holding Glass - essential for preparing new glass prior to installation.

JCB part number - 892/00843

S186280

Glass Lifter - minimum 2 off - essential for glass installation, 2 required to handle large panes of glass. Ensure suction cups are protected from damage during storage.

JCB part number - 892/00842

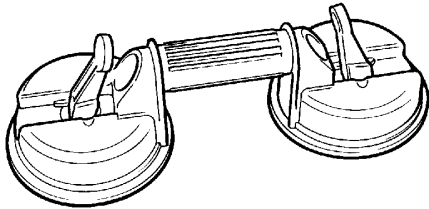

S186300

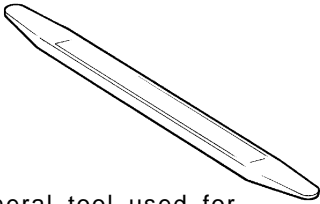

Nylon Spatula - general tool used for smoothing sealants - also used to re-install glass in rubber glazing because metal tools will chip the glass edge.

JCB part number - 892/00847

S186470

Rubber Spacer Blocks - used to provide the correct set clearance between glass edge and cab frame.

JCB part number - 926/15500 (unit quantity = 500 off)

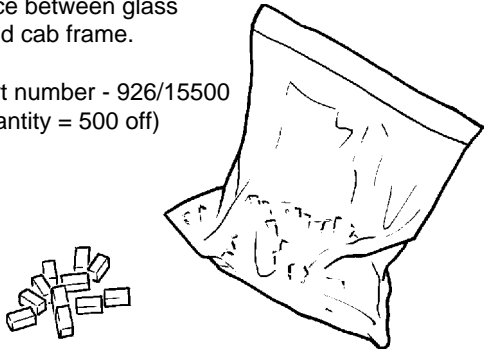

S186550

Service Tools (cont'd)

Section B - Body & Framework

Wire Starter - used to access braided cutting wire (below) through original polyurethane seal.

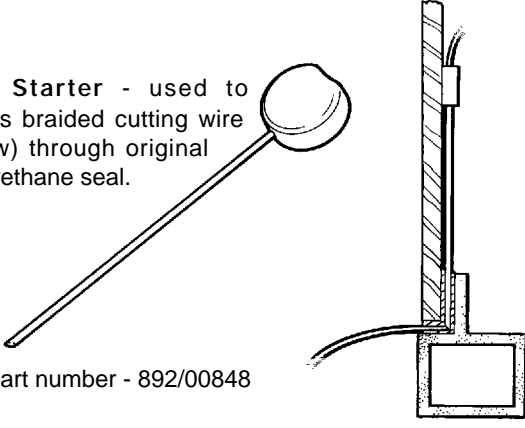

JCB part number - 892/00848

S186310

Cut-Out Knife - used to remove broken glass.

JCB part number - 992/12800

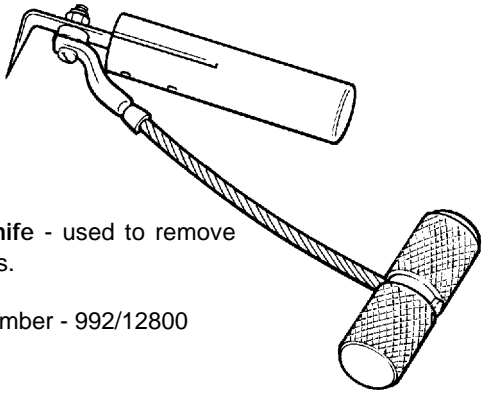

S186340

Glass Extractor (Handles) - used with braided cutting wire (below) to cut out broken glass.

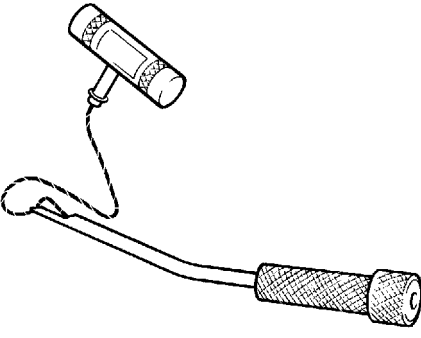

JCB part number - 892/00846

S186320

'L' Blades - 25 mm (1 in) cut - replacement blades for cut-out knife (above).

JCB part number - 992/12801 (unit quantity = 5 off)

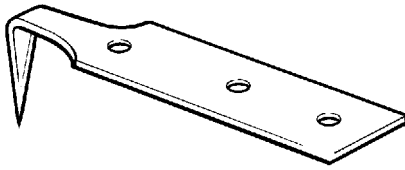

S186350

Braided Cutting Wire - consumable heavy duty cut-out wire used with the glass extraction tool (above).

JCB part number - 892/00849 (approx 25 m length)

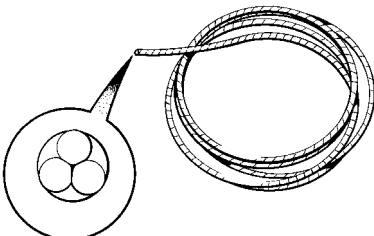

S186330

Long Knife - used to give extended reach for normally inaccessible areas.

JCB part number - 892/00844

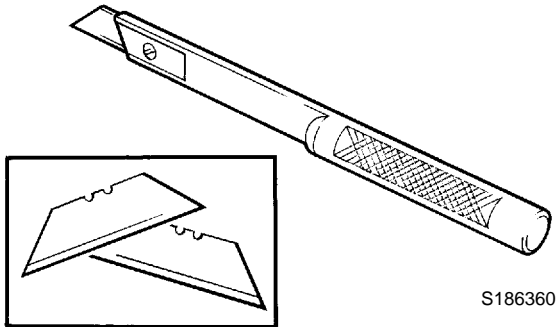

S186360

Service Tools

Section C - Electrics

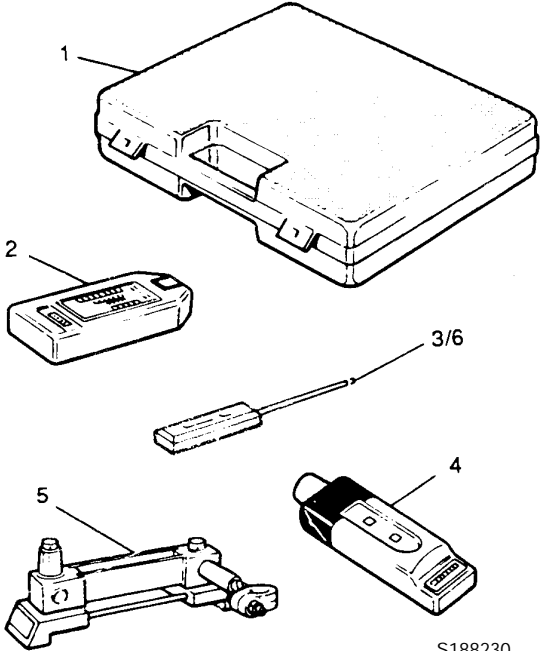

AVO Test Kit

1	892/00283	Tool Kit Case
2	892/00298	Fluke Meter
3	892/00286	Surface Temperature Probe
4	892/00284	Venture Microtach Digital Tachometer
5	892/00282	100 amp Shunt - open type
6	892/00285	Hydraulic Temperature Probe

S188230

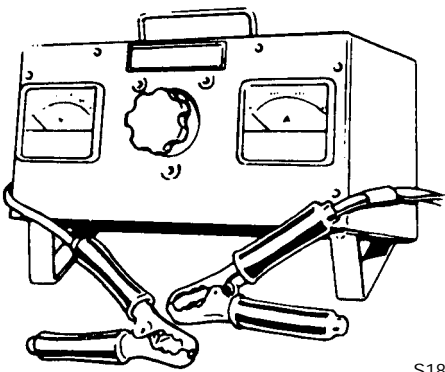

892/00121 High Rate Discharge Tester (400 amps) for testing battery condition

S188240

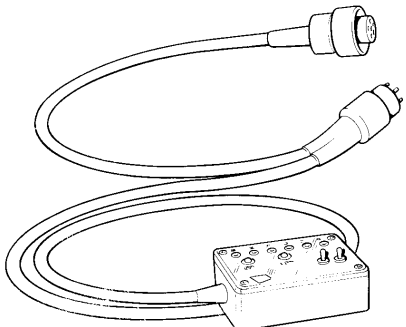

992/10900 Test Harness for Safe Load Indicator
993/99412 Adaptor Harness

S188250

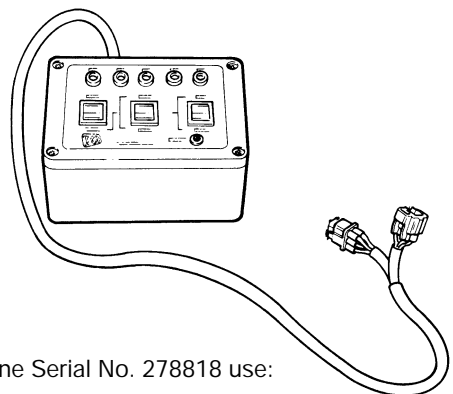

From machine Serial No. 278818 use:

* 892/00905 Test Box For Safe Load Indicator (SLI) and Load Moment Indicator (LMI) S244692

Service Tools

Section C - Electrics

Recommended Electrical Repair Kit

2A :7212/0002	2 Way Pin Housing	6A :7216/0002	6 Way Pin Housing
2B :7212/0004	2 Way Pin Retainer	6B :7216/0004	6 Way Pin Retainer
2C :7212/0003	2 Way Socket Retainer	6C :7216/0003	6 Way Socket Retainer
2D :7212/0001	2 Way Socket Connector	6D :7216/0001	6 Way Socket Connector
3A :7213/0002	3 Way Pin Housing	7A :7218/0002	8 Way Pin Housing
3B :7213/0004	3 Way Pin Retainer	7B :7218/0004	8 Way Pin Retainer
3C :7213/0003	3 Way Socket Retainer	7C :7218/0003	8 Way Socket Retainer
3D :7213/0001	3 Way Socket Connector	7D :7218/0001	8 Way Socket Connector
4A :7213/0006	3 Way Pin Housing (DT)	8A :7219/0002	10 Way Pin Housing
4B :7213/0008	3 Way Pin Retainer (DT)	8B :7219/0004	10 Way Pin Retainer
4C :7213/0007	3 Way Socket Retainer (DT)	8C :7219/0003	10 Way Socket Retainer
4D :7213/0005	3 Way Socket Connector (DT)	8D :7219/0001	10 Way Socket Connector
5A :7214/0002	4 Way Pin Housing	9A :7219/0006	14 Way Pin Housing
5B :7214/0004	4 Way Pin Retainer	9B :7219/0008	14 Way Pin Retainer
5C :7214/0003	4 Way Socket Retainer	9C :7219/0007	14 Way Socket Retainer
5D :7214/0001	4 Way Socket Connector	9D :7219/0005	14 Way Socket Connector
		10 :7210/0001	Dummy Plug
		11 :7210/0002	Wire Seal (1.4 - 2.2 mm dia.)
		12 :7210/0003	Wire Seal (2.2 - 2.9 mm dia.)

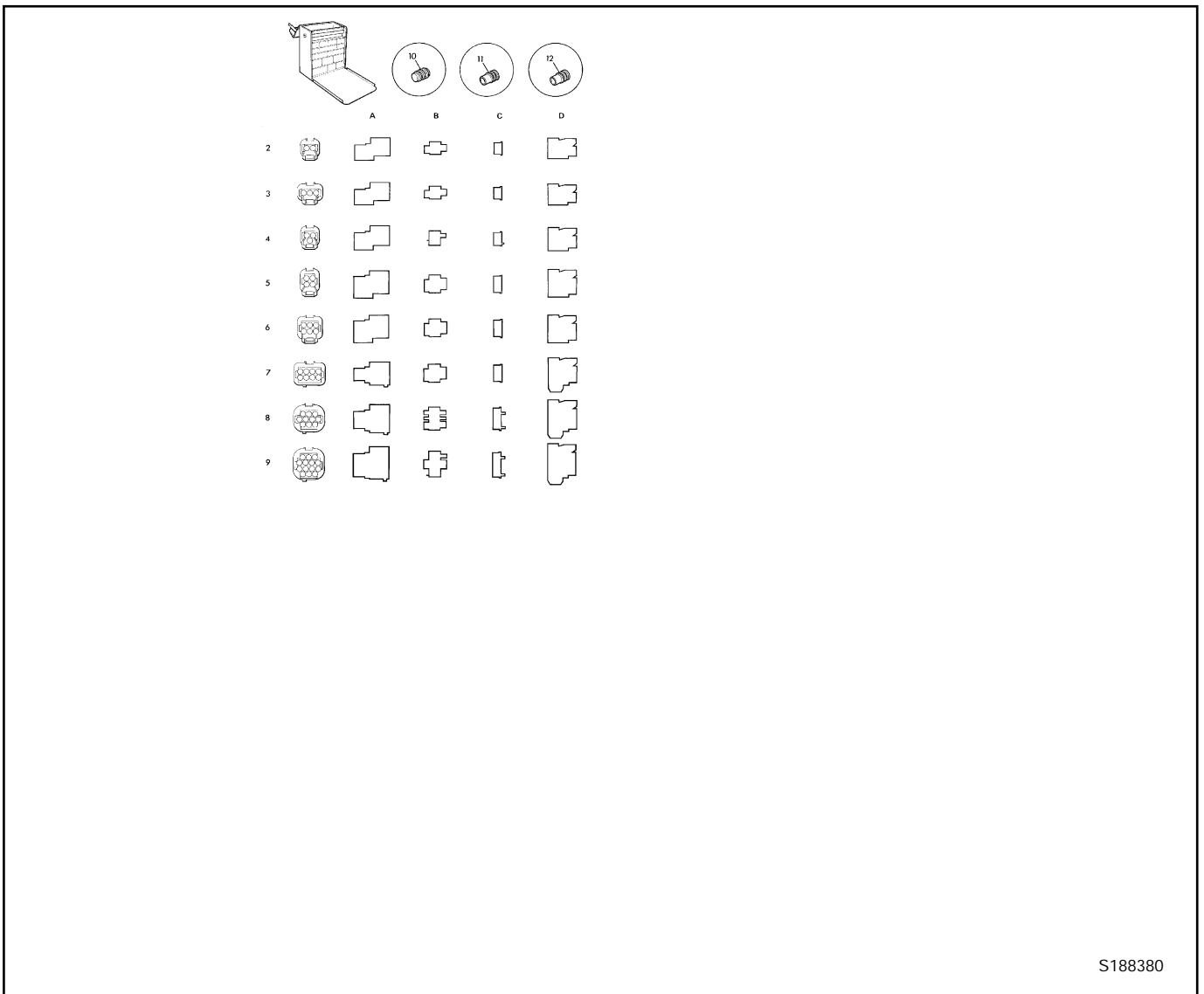

S188380

Buy Now



Our support email:

ebooklibonline@outlook.com