

Service Manual

JS200LC
JS240LC
JS300LC
JS450LC

PUBLISHED BY THE
TECHNICAL PUBLICATIONS DEPARTMENT
OF JCB SERVICE; ©
ROCESTER, STAFFORDSHIRE, ST14 5LS,
ENGLAND

Tel. ROCESTER (0889) 590312
PRINTED IN ENGLAND

Publication No. 9803/6200

General Information	1
Care & Safety	2
Routine Maintenance	3
Optional Equipment	A
Body & Framework	B
Electrics	C
Hydraulics	E
Transmission	F
Brakes	G
Track & Running Gear	J
Engine	K

Contents	Page No.
Machine Identification	1 - 1
Torque Settings	2 - 1
Service Tools	
Section - C Electrics	4 - 1
Section - E Hydraulics	5 - 1
Section - F Transmission	6 - 1
Sealing and Retaining Compounds	7 - 1

Your machine has a Data Plate, located to the rear left, inside the cab as shown **A**. The machine serial number is inscribed at **B** and the engine number at **C**.

If the engine is replaced by a new one, the data plate serial number will be wrong. Either stamp the new number on the plate or stamp out the old one. This will prevent the wrong number being quoted when you order replacement parts.

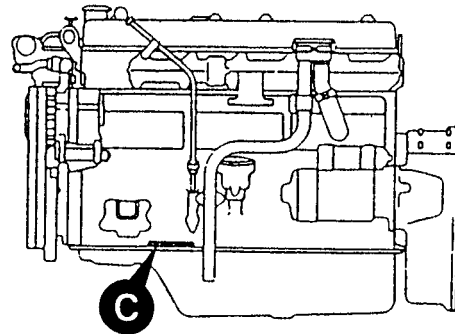
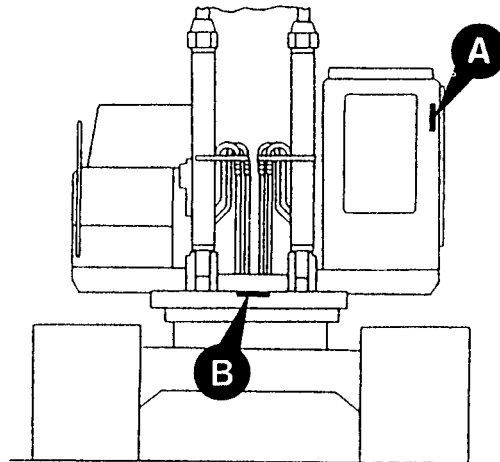

JS200LC, JS24LC

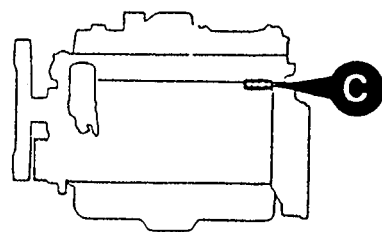

JS300LC

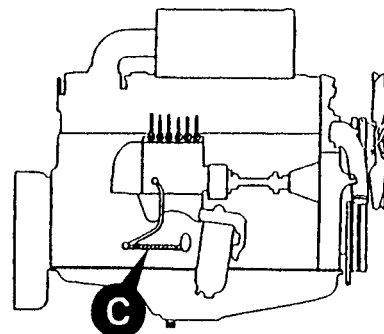

JS450LC

Torque Settings

Note 1: The figures quoted are for non-plated fasteners and are to be used only when there is no torque setting specified in the relevant procedure in this service manual.

Note 2: The 4T grade settings DO NOT APPLY to fasteners used on the engine. If any 4T specification fasteners are found on the engine these must be tightened to the figure quoted in the relevant engine manual.

Bolt Size	Strength Grade of Bolt or Stud								
	4T			8.8			10.9		
	Nm	kgf m	lbf ft	Nm	kgf m	lbf ft	Nm	kgf m	lbf ft
M3	0.39	0.04	0.28	-	-	-	-	-	-
M4	0.78	0.08	0.57	-	-	-	-	-	-
M5	1.67	0.17	1.2	-	-	-	-	-	-
M6	2.84	0.29	2.1	8.04	0.82	5.9	11.3	1.15	8.3
M8	7.06	0.72	5.2	19.6	2.00	14.5	27.7	2.82	20.4
M10	14.0	1.43	10.3	39.1	3.99	28.8	55.0	5.61	40.6
M12	24.6	2.51	18.1	68.5	6.98	50.5	96.2	9.81	71
M16	61.9	6.31	45.7	173	17.6	127.6	242	24.7	178.5
M20	122	12.4	90	337	34.4	249	475	48.4	350
M22	167	17.0	123	464	47.3	342	652	66.5	481
M24	210	21.4	155	584	59.5	431	821	83.7	606
M27	311	31.7	229	864	88.1	637	1220	124	900
M30	420	42.8	310	1170	119	863	1650	168	1217
M33	576	58.7	425	1600	163	1180	2260	230	1667
M36	736	75.1	543	2050	209	1512	2880	294	2124
M39	961	98.0	709	2680	273	1977	3760	383	2773
M42	1190	121	878	3300	336	2434	4640	473	3422
M45	1490	152	1099	4140	422	3054	5820	593	4293
M48	1780	182	1312	4960	506	3659	6970	711	5141

Service Tools

SECTION C - ELECTRICS

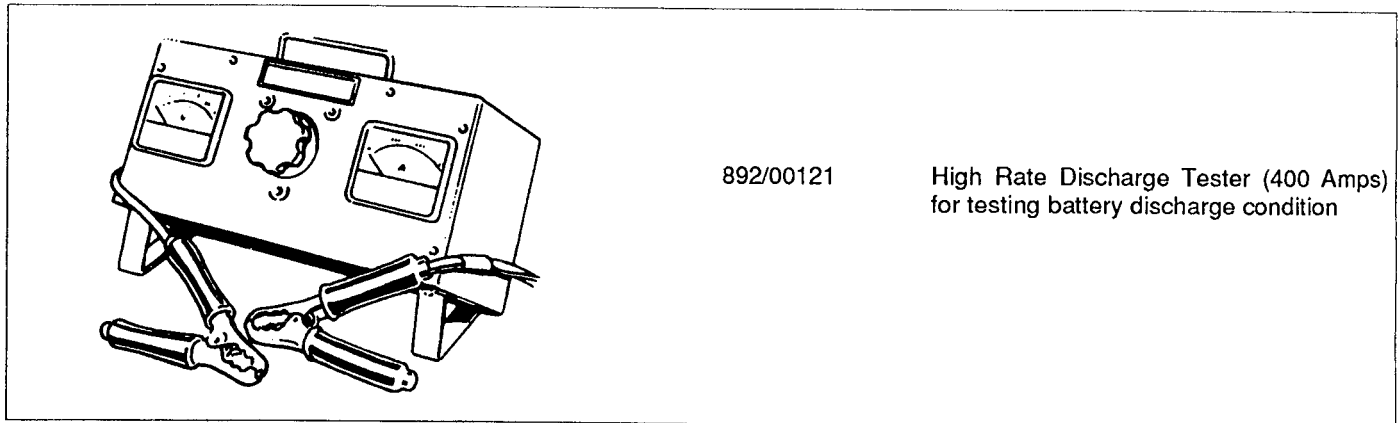
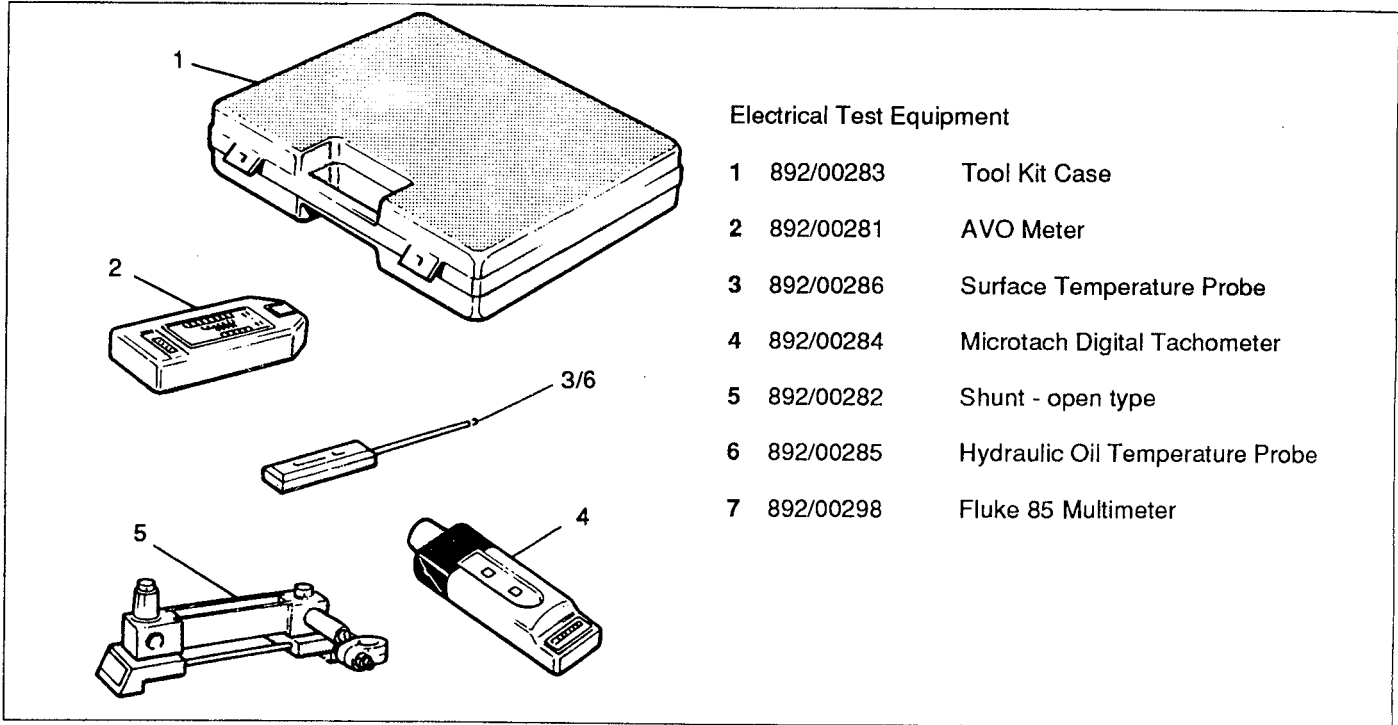

Service Tools (continued)

SECTION E - HYDRAULICS

Hydraulic Pressure Test Gauges and Connections

- 1 892/00279 Pressure Gauge 0-400 bar (0-6000 lbf/in²)
- 2 892/00346 Pressure Gauge 0-70 bar (0-1000 lbf/in²)
- 3 892/00347 Connector
- 4 892/00254 Hose

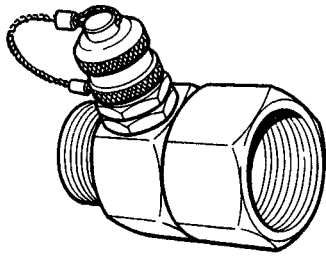
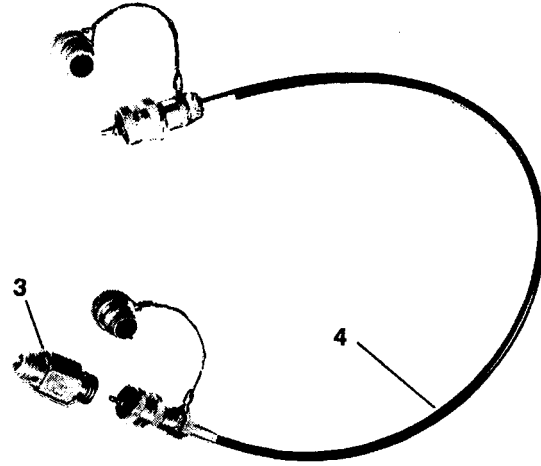
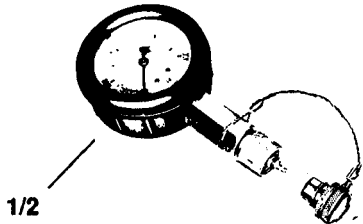

Pressure Test 'T' Adapters

- 892/00262 1/4 in M BSP x 1/4 in F BSP x Test Point
- 816/55038 3/8 in M BSP x 3/8 in F BSP x Test Point
- 816/55040 1/2 in M BSP x 1/2 in F BSP x Test Point
- 892/00263 5/8 in M BSP x 5/8 in F BSP x Test Point
- 892/00264 3/4 in M BSP x 3/4 in F BSP x Test Point
- 892/00265 1 in M BSP x 1 in F BSP x Test Point
- 892/00266 1,1/4 in M BSP x 1,1/4 in F BSP x Test Point
- 892/00267 1,1/2 in M BSP x 1,1/2 in F BSP x Test Point

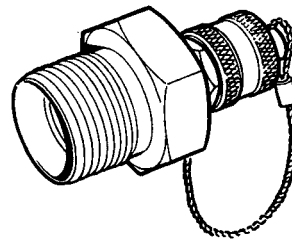

Pressure Test Adapters

- 892/00255 1/4 in BSP x Test Point
- 892/00256 3/8 in BSP x Test Point
- 892/00257 1/2 in BSP x Test Point
- 892/00258 5/8 in BSP x Test Point
- 816/15118 3/4 in BSP x Test Point
- 892/00259 1 in BSP x Test Point
- 892/00260 1,1/4 in BSP x Test Point
- 892/00261 5/8 in UNF x Test Point

Service Tools (continued)

SECTION E - HYDRAULICS

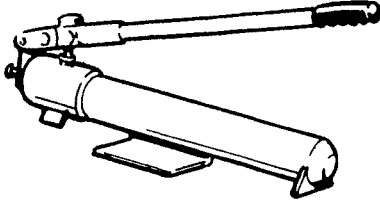

Hand Pump Equipment

892/00223	Hand Pump
892/00137	Micro-bore Hose 1/4 in BSP x 5 metres
892/00274	Adapter 1/4 in M BSP x 3/8 in M BSP Taper
892/00262	1/4 in M BSP x 1/4 in F BSP x Test Point
892/00706	Test Probe
892/00278	Gauge 0 - 40 bar (0 - 600 lbf/in ²)
892/00279	Gauge 0 - 400 bar (0 - 6000 lbf/in ²)
892/00280	Gauge 0 - 600 bar (0 - 8500 lbf/in ²)

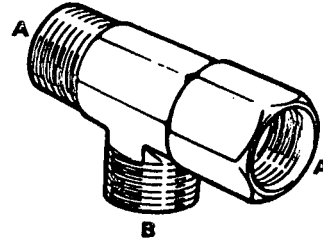

816/50005	1/2 in. BSP (A) x 1/2 in. BSP (B)
816/60096	3/4 in. BSP (A) x 3/4 in. BSP (B)
816/00018	1 in. BSP (A) x 1 in. BSP (B)

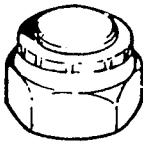

Female Cone Blanking Plug

892/00055	1/4 in. BSP
892/00056	3/8 in. BSP
892/00057	1/2 in. BSP
892/00058	5/8 in. BSP
892/00059	3/4 in. BSP
892/00060	1 in. BSP

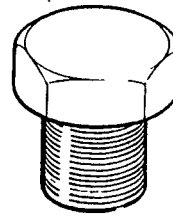

Male Cone Blanking Cap

816/00294	1/4 in. BSP
816/00189	3/8 in. BSP
816/00190	1/2 in. BSP
816/00197	5/8 in. BSP
816/00196	3/4 in. BSP
816/00193	1 in. BSP

Service Tools (continued)

SECTION E - HYDRAULICS

Hydraulic Pump - JS 200LC, 300LC and 450LC

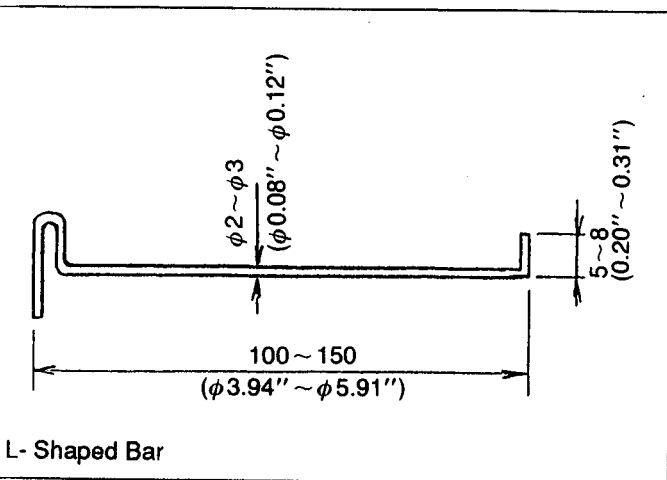
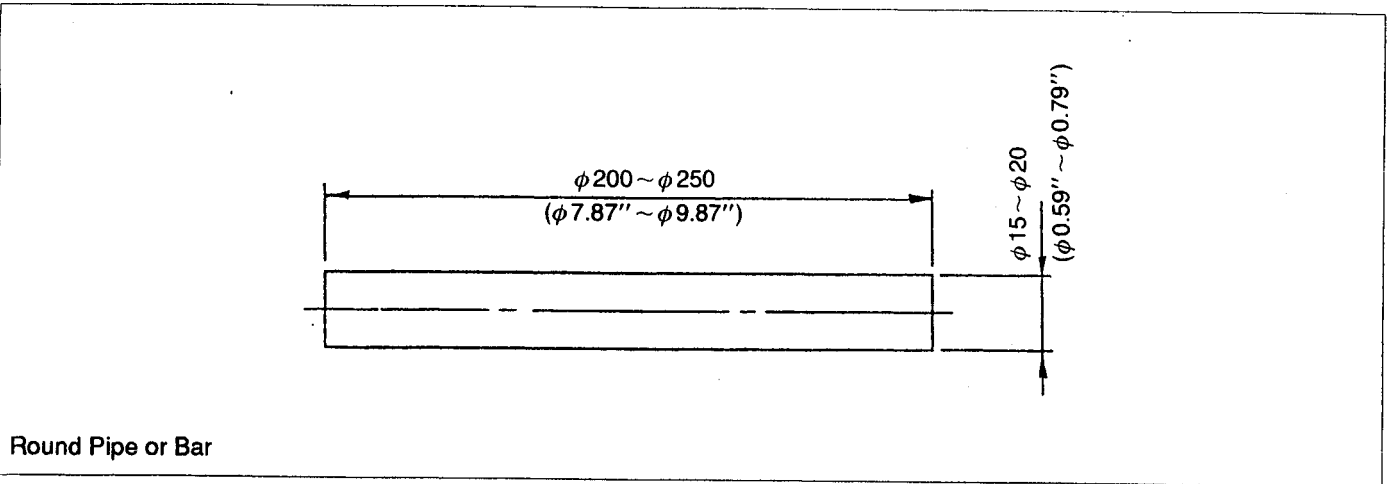
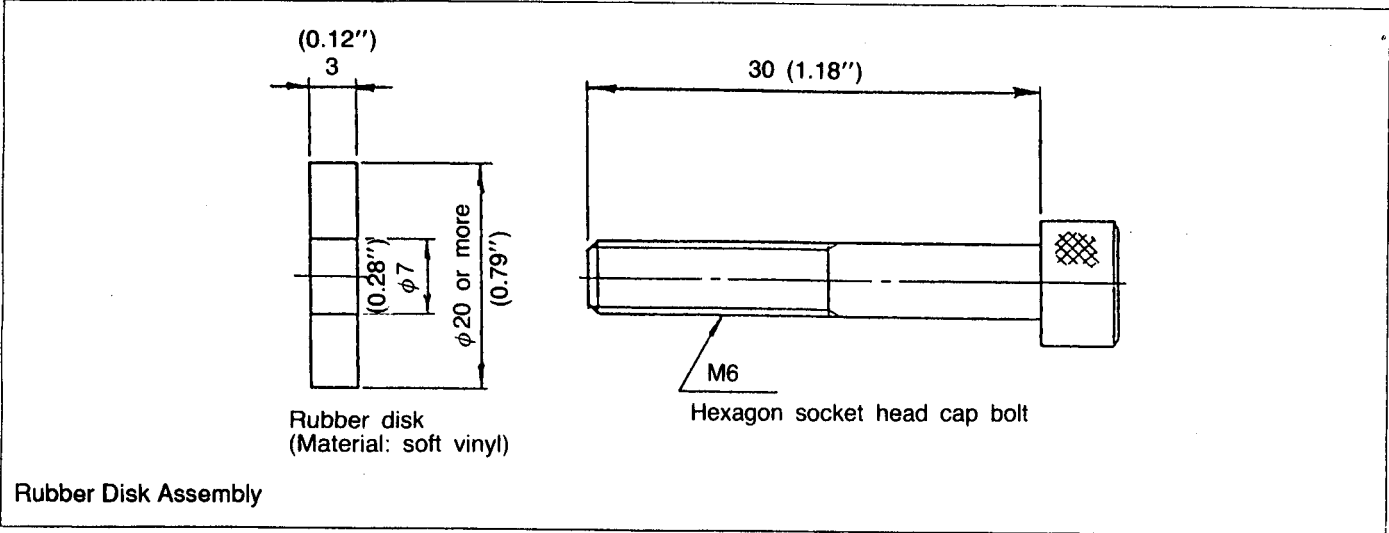

Service Tools (continued)

SECTION E - HYDRAULICS

Swing Motor Unit - JS 200LC

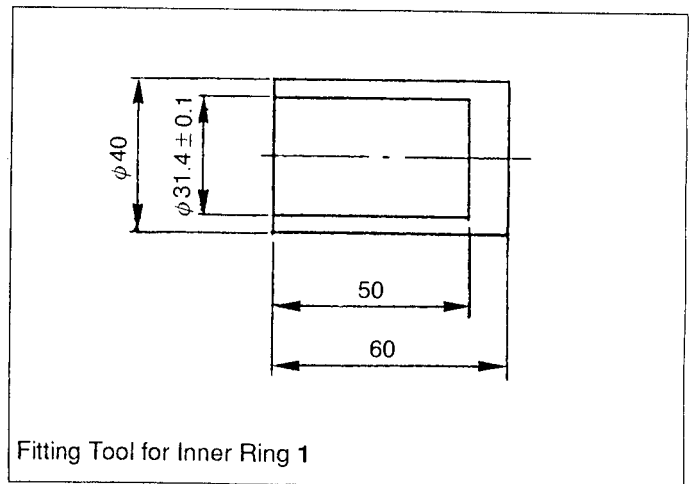
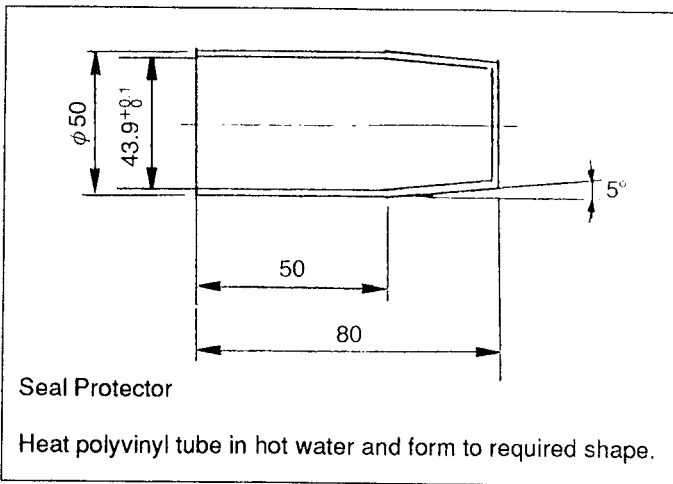
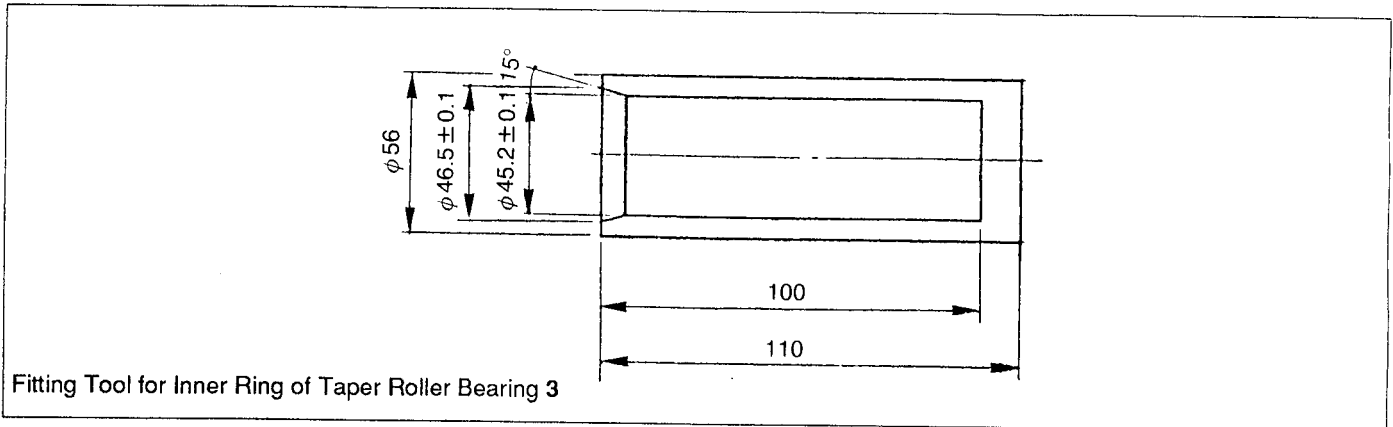
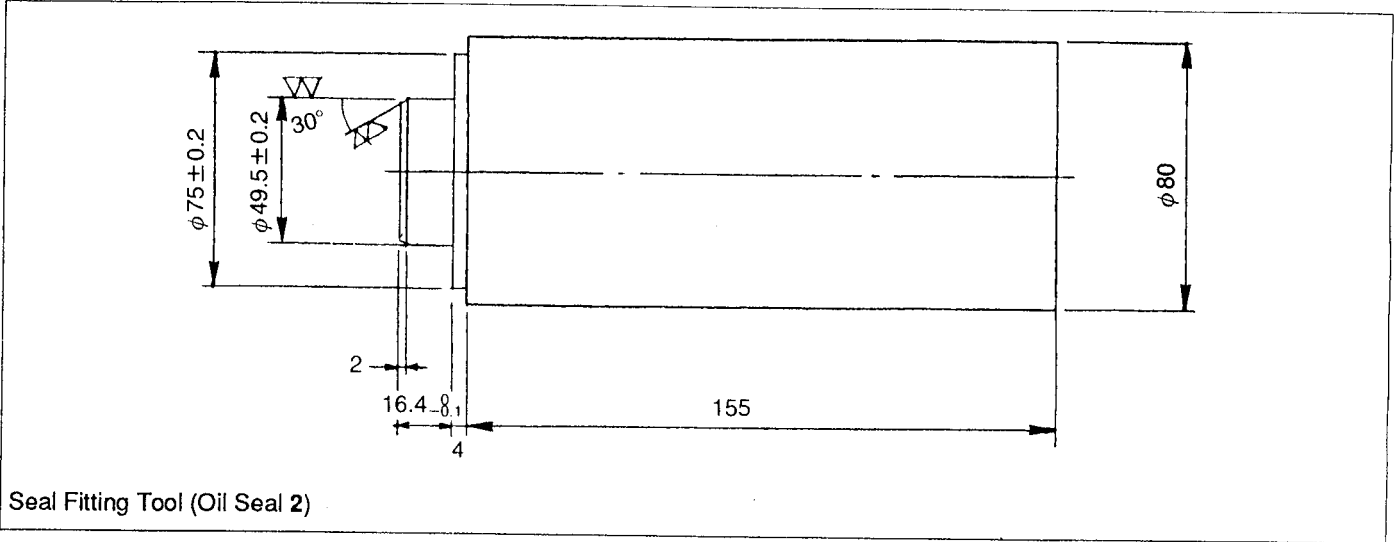

Service Tools (continued)

SECTION E - HYDRAULICS

Swing Motor Unit - JS 300LC

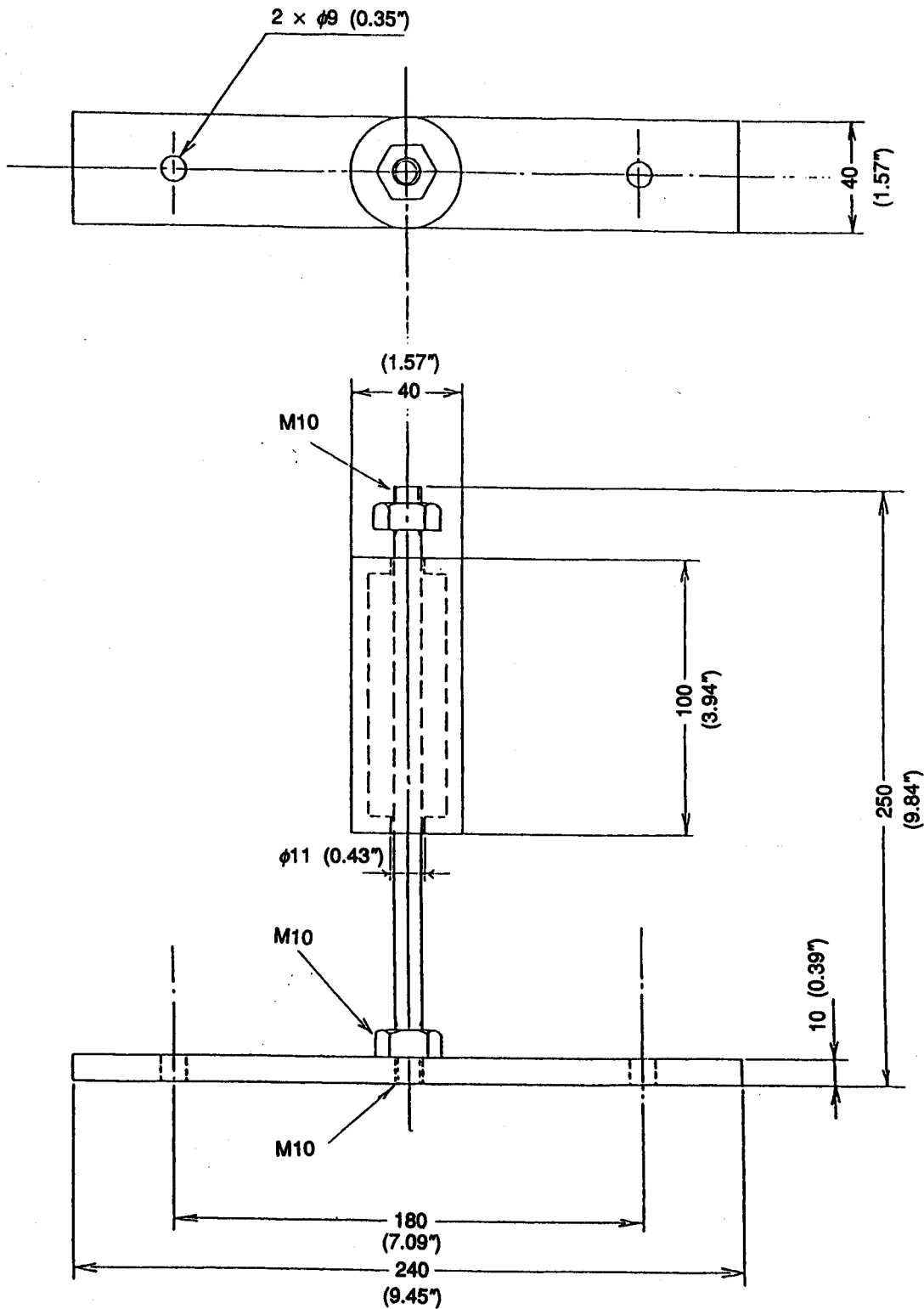

Puller for Brake Piston

Stud is threaded M10 on both ends for 20 mm (0.8 in) and fitted with two M10 nuts.

Service Tools (continued)

SECTION E - HYDRAULICS

Hydraulic Tank - JS 200LC and 300LC

	JS200LC	JS300LC
A	Dia. 40mm (1.57in)	
B	Dia. 26mm (1.02in)	
C	40mm (1.57in)	
D	50mm (1.97in)	
E	Dia. 10mm (0.39in)	
F	600mm (23.6in)	650mm (25.6in)
G	9mm (0.35in)	
H	24mm (0.94in)	30mm (1.18in)
I	Dia. 95mm $^{+0}_{-0.1}$ (3.74in $^{+0}_{-0.004}$)	
J	Dia. 90mm $^{+0}_{-0.1}$ (3.54in $^{+0}_{-0.004}$)	
K	110 mm (4.33 in)	
L	4.1mm (0.16in)	
M	Radius 0.7mm (0.028in)	
N	130mm (5.12in)	
O	4.0mm (0.16in)	-
P	3.0mm (0.118in)	-
Q	15°	-
O-ring	G90	

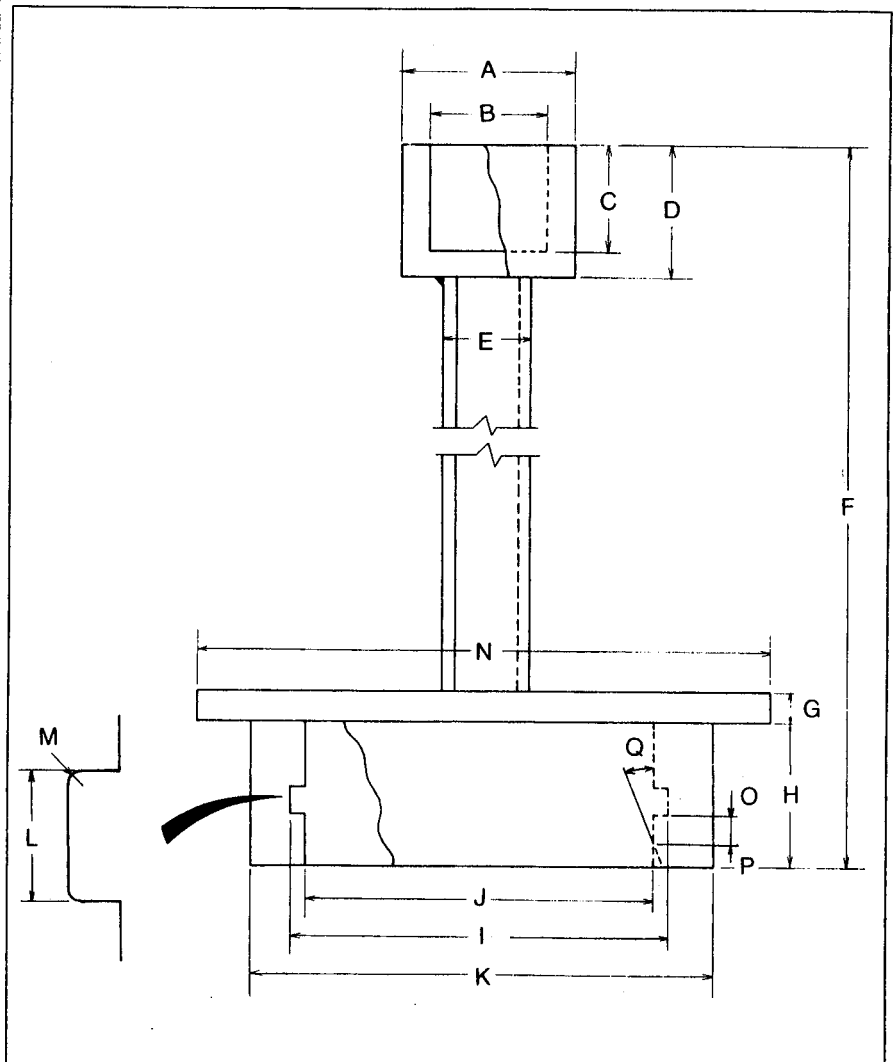

Blank for Suction Strainer

Service Tools (continued)

SECTION E - HYDRAULICS

Servo Hand Control Valve - JS 200LC, 240LC and 450LC

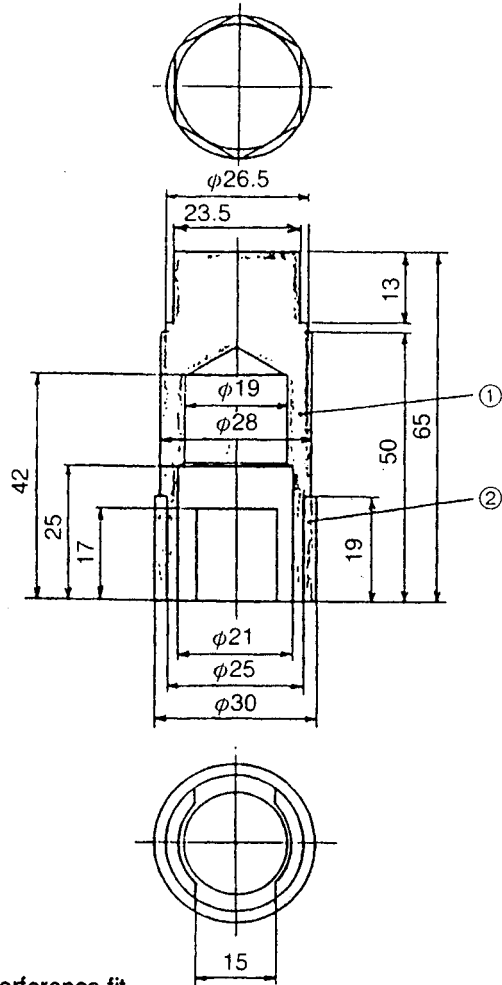

Joint Removal Tool

Items 1 and 2 are assembled with an interference fit.

Service Tools (continued)

SECTION E - HYDRAULICS

Rotary Coupling - JS 240LC, 300LC and 450LC

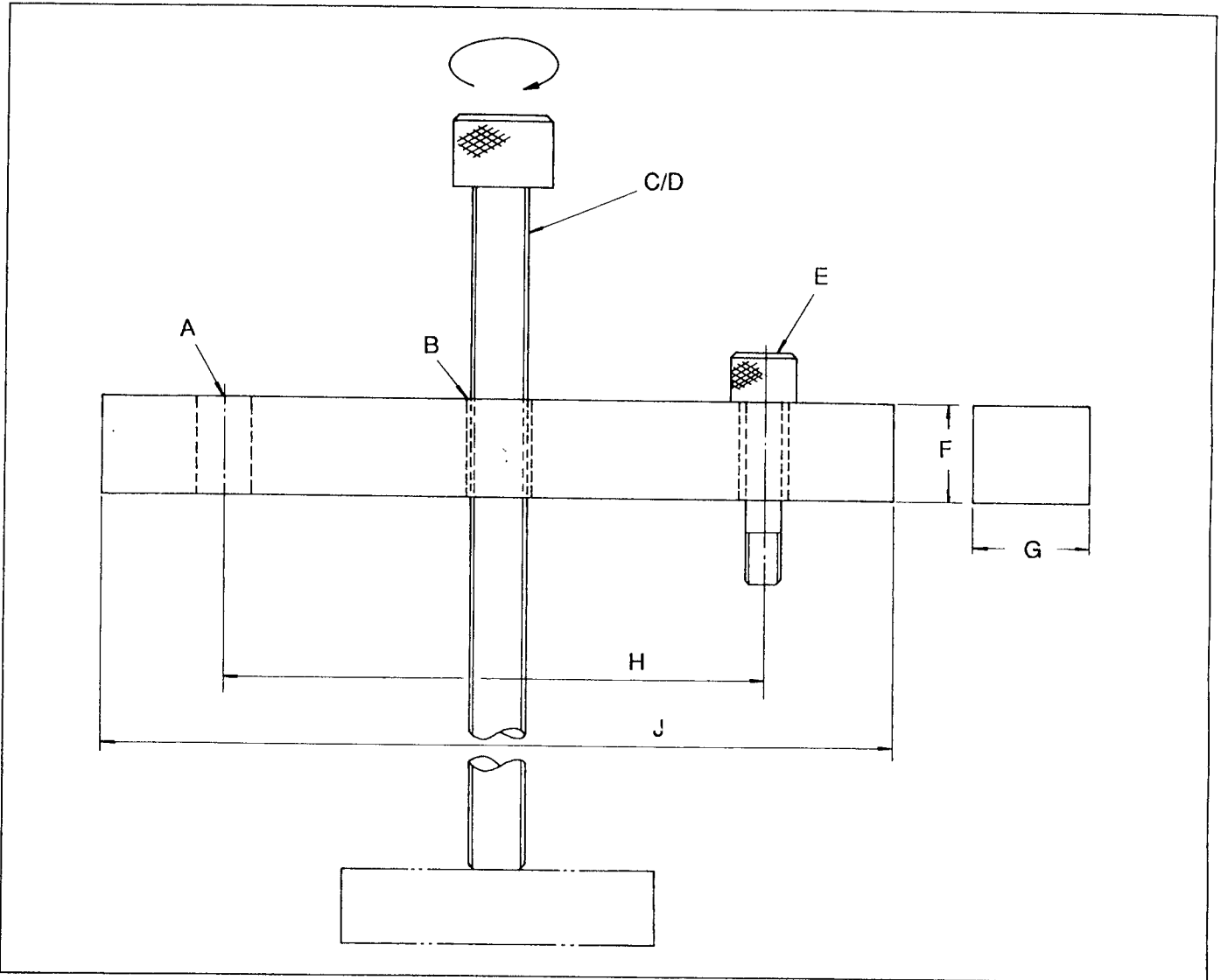

	JS 240LC	JS 300LC	JS 450LC
A	10mm (0.4in)	12mm (0.5in)	14mm (0.55in)
B	M12~M20	M12~M20	M16~M20
C	M12~M20	M12~M20	M16~M20
D	300mm (11.8in)~400mm (15.75in)	300mm (11.8in)~400mm (15.75in)	350mm (13.8in)~400mm (15.75in)
E	M8 x 40	M10 x 45	M12 x 45
F	30mm (1.18in)	30mm (1.18in)	30mm (1.18in)
G	30mm (1.18in)~40mm (1.57in)	30mm (1.18in)~40mm (1.57in)	30mm (1.18in)~40mm (1.57in)
H	128mm (5.04in)	146mm (5.75in)	159mm (6.26in)
J	180mm (7.09in)	180mm (7.09in)	190mm (7.48in)

Service Tools (continued)

SECTION F - TRANSMISSION

Track Gearbox - JS 200LC and JS 300LC

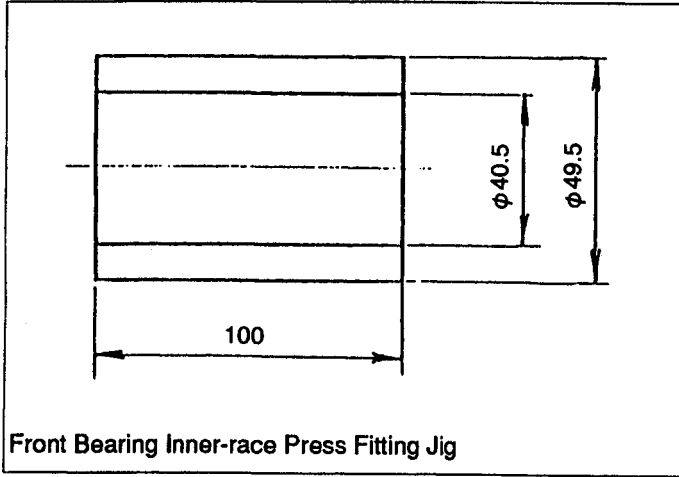

Front Bearing Inner-race Press Fitting Jig

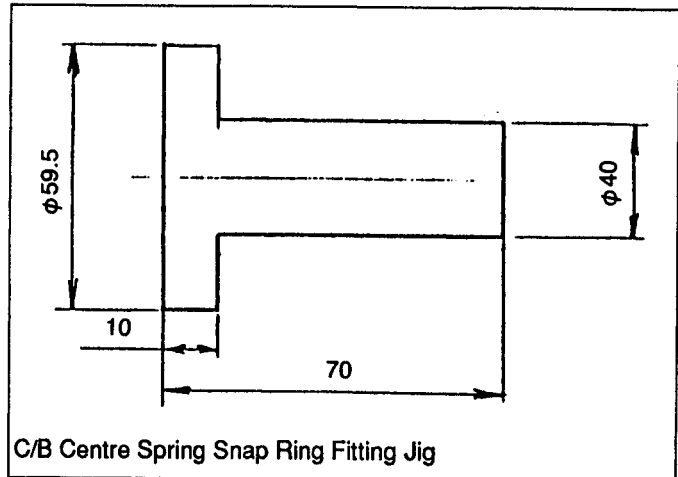

C/B Centre Spring Snap Ring Fitting Jig

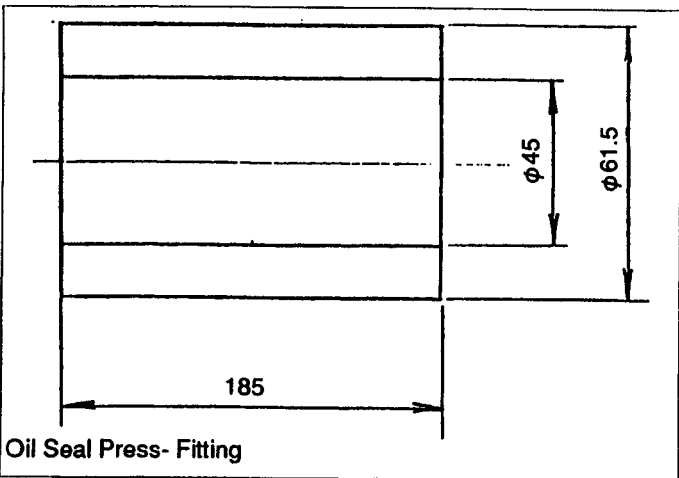

Oil Seal Press-Fitting

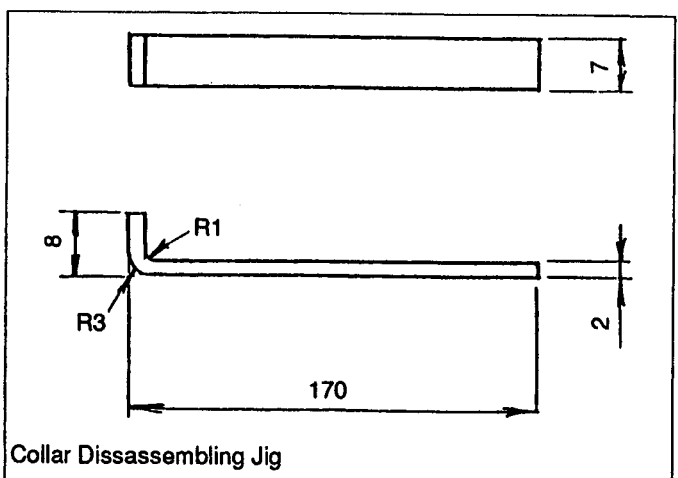

Collar Dissassembling Jig

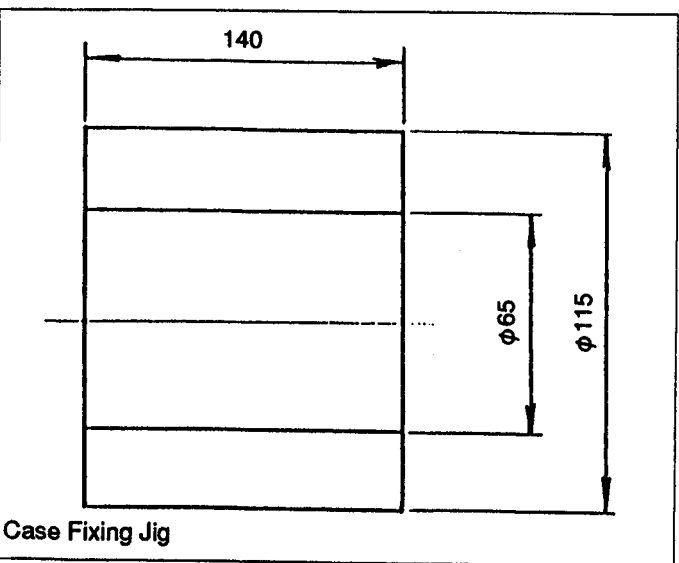

Case Fixing Jig

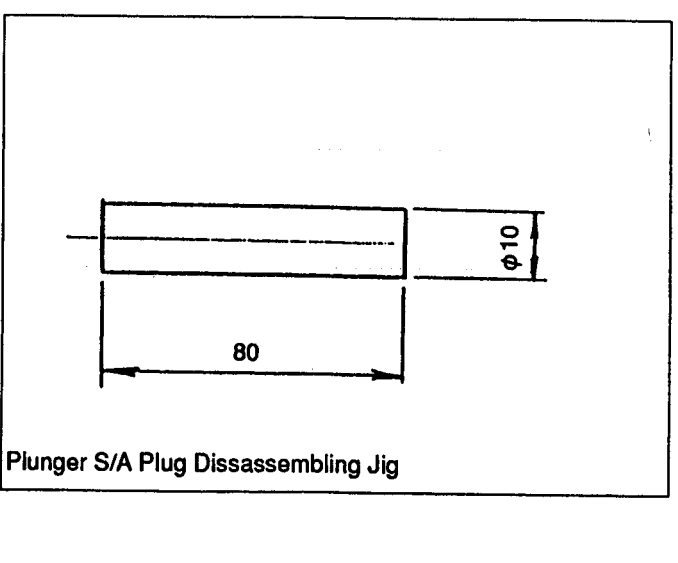

Plunger S/A Plug Dissassembling Jig

Buy Now



Our support email:

ebooklibonline@outlook.com