



Service Manual

JZ 70

From machine no.834000

PUBLISHED BY THE
TECHNICAL PUBLICATIONS DEPARTMENT
OF JCB SERVICE: ©
CHEADLE ROAD, UTTOXETER
STAFFORDSHIRE, ST14 7BS,
ENGLAND
Tel. (01889) 590312
PRINTED IN ENGLAND

Publication No. 9803/6030
Issue 0

General Information	1
Care & Safety	2
Routine Maintenance	3
Attachments	A
Body & Framework	B
Electrics	C
Controls	D
Hydraulics	E
Transmission	F
Track & Running Gear	J
Engine	K

Introduction

This publication is designed for the benefit of JCB Distributor Service Engineers who are receiving, or have received, training by JCB Technical Training Department.

These personnel should have a sound knowledge of workshop practice, safety procedures, and general techniques associated with the maintenance and repair of hydraulic earthmoving equipment.

Renewal of oil seals, gaskets, etc., and any component showing obvious signs of wear or damage is expected as a matter of course. It is expected that components will be cleaned and lubricated where appropriate, and that any opened hose or pipe connections will be blanked to prevent excessive loss of hydraulic fluid and ingress of dirt. Finally, please remember above all else **SAFETY MUST COME FIRST!**

The manual is compiled in sections, the first three are numbered and contain information as follows:

- 1 = General Information** - includes torque settings and service tools.
- 2 = Care & Safety** - includes warnings and cautions pertinent to aspects of workshop procedures etc.
- 3 = Routine Maintenance** - includes service schedules and recommended lubricants for the whole machine.

The remaining sections are alphabetically coded and deal with Dismantling, Overhaul etc. of specific components, for example:

- A = Attachments**
- B = Body & Framework** ...etc

The page numbering in each alphabetically coded section is not continuous. This allows for the insertion of new items in later issues of the manual.

Section contents, technical data, circuit descriptions, operation descriptions etc. are inserted at the beginning of each alphabetically coded section.

All sections are listed on the front cover; tabbed divider cards align directly with individual sections on the front cover for rapid reference.

Where a torque setting is given as a single figure it may be varied by plus or minus 3%. Torque figures indicated are for dry threads, hence for lubricated threads may be reduced by one third.

'Left Hand' and 'Right Hand' are as viewed from the rear of the machine facing forwards.

Note: In this manual the term 'swing' may sometimes be used in place of 'slew' and the term 'arm' may sometimes be used in place of 'dipper'.

Contents	Page No.
Bolt and Nut Torque Specifications	1 - 1
General Torque Settings	1 - 2
Service Tools	
Section B - Body and Framework	3 - 1
Section C - Electrics	4 - 1
Section E - Hydraulics	5 - 1
Sealing and Retaining Compounds	9 - 1

Bolt and Nut Torque Specifications

Tighten the bolts and nuts according to the table. Before and after daily work, check the bolts and nuts for looseness and for those missing. Tighten if loose and renew if missing.

Tighten the bolts and nuts after the first 50 hours of the running-in stage and every 250 hours thereafter.

Torque Tightening Table

No	Tightening Point	Bolt Diameter	Wrench	Tightening Torque		
				Nm	kgf m	lbf ft
			mm			
1†	Travel Motor	M16	24	268~312	27.2~31.8	197~230
2†	Drive Sprocket	M14	22	173~202	17.6~20.6	128~149
3†	Idler Wheel	M10	17	63~73	6.9~7.4	46~54
4†	Upper (Carrier) Roller	M16	24	267~312	27.2~31.8	197~230
5†	Lower (Track) Roller	M12	19	109~127	11~13	80~94
6†	Grease Cylinder	M12	19	109~127	11~13	80~94
7†	Track Guard	M12	19	109~127	11~13	80~94
8	Shoe Bolt	U1/2 - 38	19	196~235	20~24	145~173
9†	Counterweight	M24	36	660~770	67.3~78.5	487~568
10†	Turntable Bearing (Undercarriage)	M16	24	252~283	25.7~28.9	186~209
11†	Turntable Bearing (Slew Frame)	M16	24	252~283	25.7~28.9	186~209
12†	Slew Equipment	M16	24	273~318	27.8~32.4	201~235
13†	Engine (Engine Mount)	M16	24	167~216	17~22	123~159
14†	Engine Bracket	M10/M16	17/24	65~75/167~216	6.6~7.7/17~22	48~55/123~159
15	Radiator	M10	17	30~35	3.1~3.6	22~26
16†	Hydraulic Pump	M10/M12	17/19	63~73/109~127	6.4~7.4/11~13	46~54/80~94
17†	Hydraulic Oil Tank	M16	24	160~172	16.3~17.5	118~127
18†	Fuel Tank	M16	24	160~172	16.3~17.5	118~127
19†	Control Valve	M12	19	53~65	5.4~6.6	39~48
20†	Rotary Coupling	M10	17	63~73	6.4~7.4	46~54
21	Cab	M16	24	79~88	8~9	58~65
22	Battery	M10	17	20~30	2~3	15~22

Note: Use JCB Threadlocker and Sealer (High Strength) on those marked † and tighten to the torque listed in the above table.

General Torque Settings

Note 1: The figures quoted are for non-plated fasteners and are to be used only when there is no torque setting specified in the relevant procedure in this service manual.

Note 2: The 4T grade settings DO NOT APPLY to fasteners used on the engine. If any 4T specification fasteners are found on the engine, these must be tightened to the figure quoted in the relevant engine manual.

Bolt Size	Strength Grade of Bolt or Stud								
	4T			8.8			10.9		
	Nm	kgf m	lbf ft	Nm	kgf m	lbf ft	Nm	kgf m	lbf ft
M3	0.39	0.04	0.28	-	-	-	-	-	-
M4	0.78	0.08	0.57	-	-	-	-	-	-
M5	1.67	0.17	1.2	-	-	-	-	-	-
M6	2.84	0.29	2.1	8.04	0.82	5.9	11.3	1.15	8.3
M8	7.06	0.72	5.2	19.6	2.00	14.5	27.7	2.82	20.4
M10	14.0	1.43	10.3	39.1	3.99	28.8	55.0	5.61	40.6
M12	24.6	2.51	18.1	68.5	6.98	50.5	96.2	9.81	71
M16	61.9	6.31	45.7	173	17.6	127.6	242	24.7	178.5
M20	122	12.4	90	337	34.4	249	475	48.4	350
M22	167	17.0	123	464	47.3	342	652	66.5	481
M24	210	21.4	155	584	59.5	431	821	83.7	606
M27	311	31.7	229	864	88.1	637	1220	124	900
M30	420	42.8	310	1170	119	863	1650	168	1217
M33	576	58.7	425	1600	163	1180	2260	230	1667
M36	736	75.1	543	2050	209	1512	2880	294	2124
M39	961	98.0	709	2680	273	1977	3760	383	2773
M42	1190	121	878	3300	336	2434	4640	473	3422
M45	1490	152	1099	4140	422	3054	5820	593	4293
M48	1780	182	1312	4960	506	3659	6970	711	5141

Service Tools

Body and Framework (Section B)

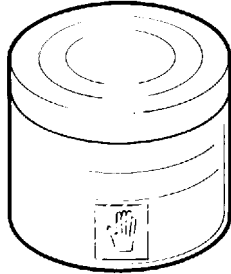

S186240

Hand Cleaner - special blend for the removal of polyurethane adhesives.

4104/1310 (454g; 1lb tub)

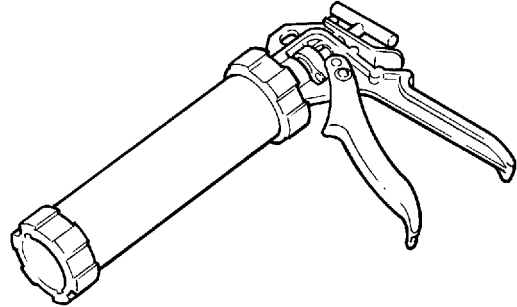

S186270

Cartridge Gun - hand operated - essential for the application of sealants, polyurethane materials etc.

892/00845

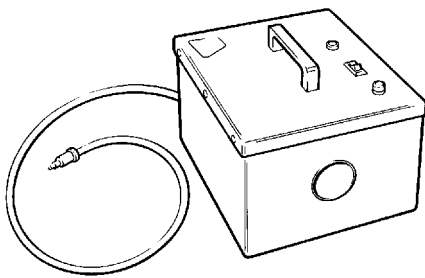

S186250

12V Mobile Oven - 1 cartridge capacity - required to pre-heat adhesive prior to use. It is fitted with a male plug (703/23201) which fits into a female socket (715/04300).

992/12300

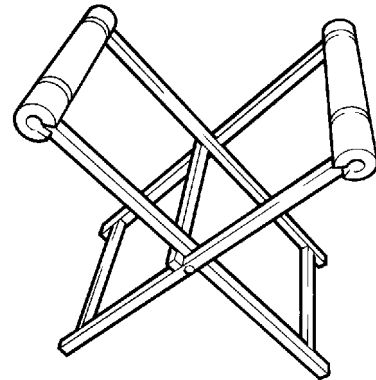

S186280

Folding Stand for Holding Glass - essential for preparing new glass prior to installation.

892/00843

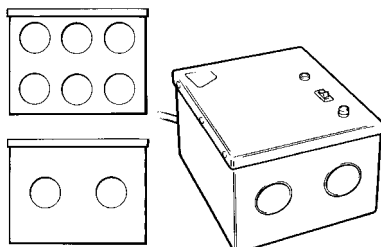

S186260

240V Static Oven - available with 2 or 6 cartridge capacity - required to pre-heat adhesive prior to use. No plug supplied. Note: 110V models available upon request - contact JCB Technical Service

992/12400 - 2 cartridge x 240V
992/12600 - 6 cartridge x 240V

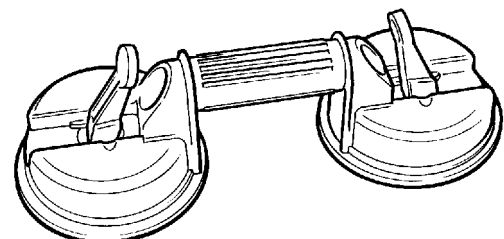

S186300

Glass Lifter - minimum 2 off - essential for glass installation, 2 required to handle large panes of glass. Ensure suction cups are protected from damage during storage.

892/00842

Service Tools (cont'd)

Body and Framework (Section B) (cont'd)

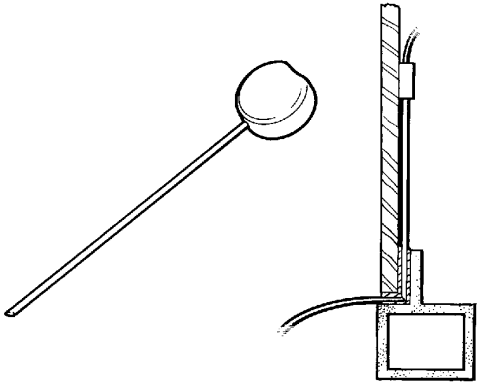

S186310

Wire Starter - used to access braided cutting wire (below) through original polyurethane seal.

892/00848

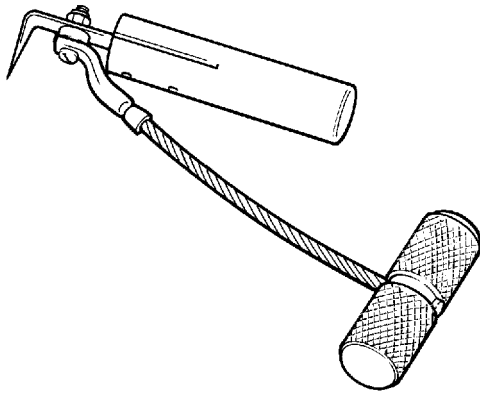

S186340

Cut-out Knife - used to remove broken glass.

992/12800

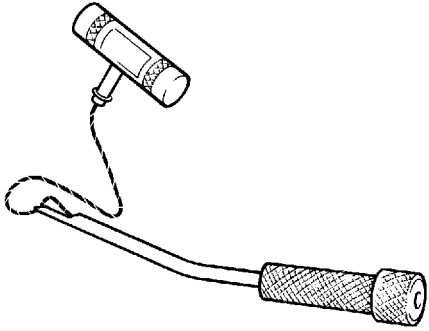

S186320

Glass Extractor (Handles) - used with braided cutting wire (below) to cut out broken glass.

892/00846

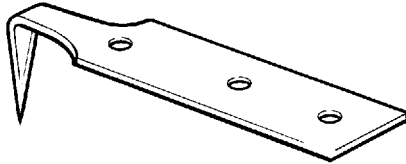

S186350

'L' Blades - 25mm (1in.) cut - replacement blades for cut-out knife (above).

992/12801 (unit quantity = 5 off)

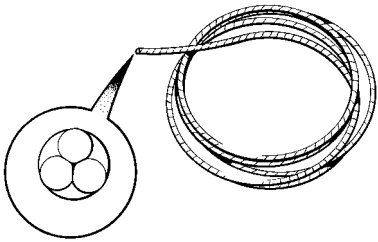

S1863

Braided Cutting Wire - consumable heavy duty cut-out wire used with the glass extraction tool (above).

892/00849 (approx 25m length)

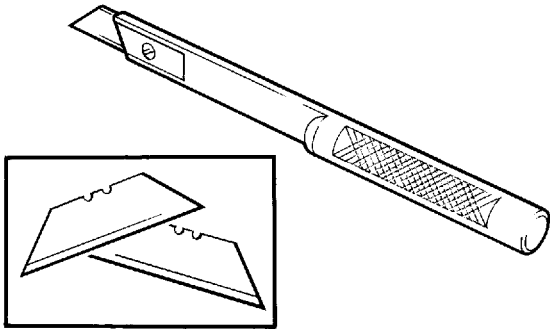

S186360

Long Knife - used to give extended reach for normally inaccessible areas.

892/00844

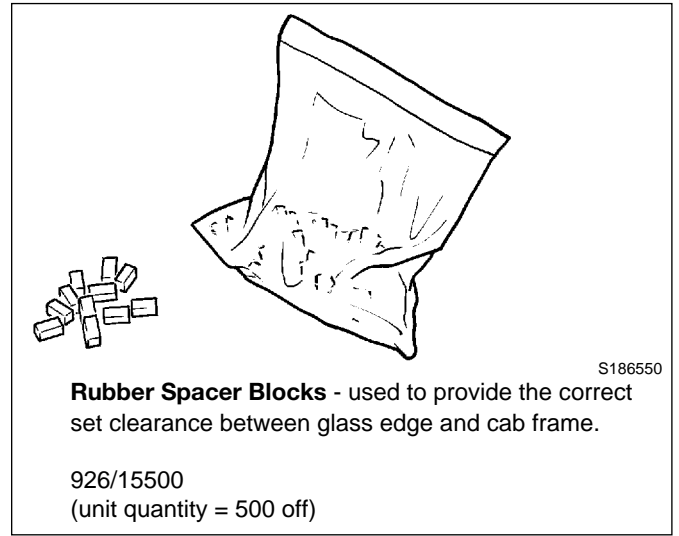
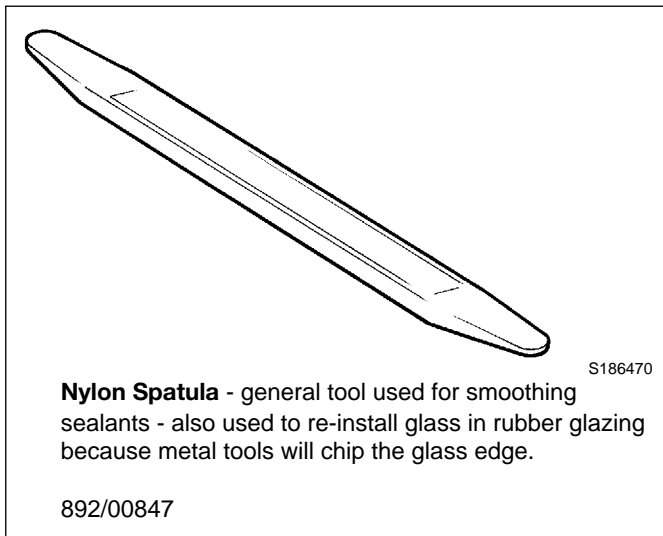
Service Tools (cont'd)**Body and Framework (Section B) (cont'd)**

Service Tools

SECTION C - ELECTRICS

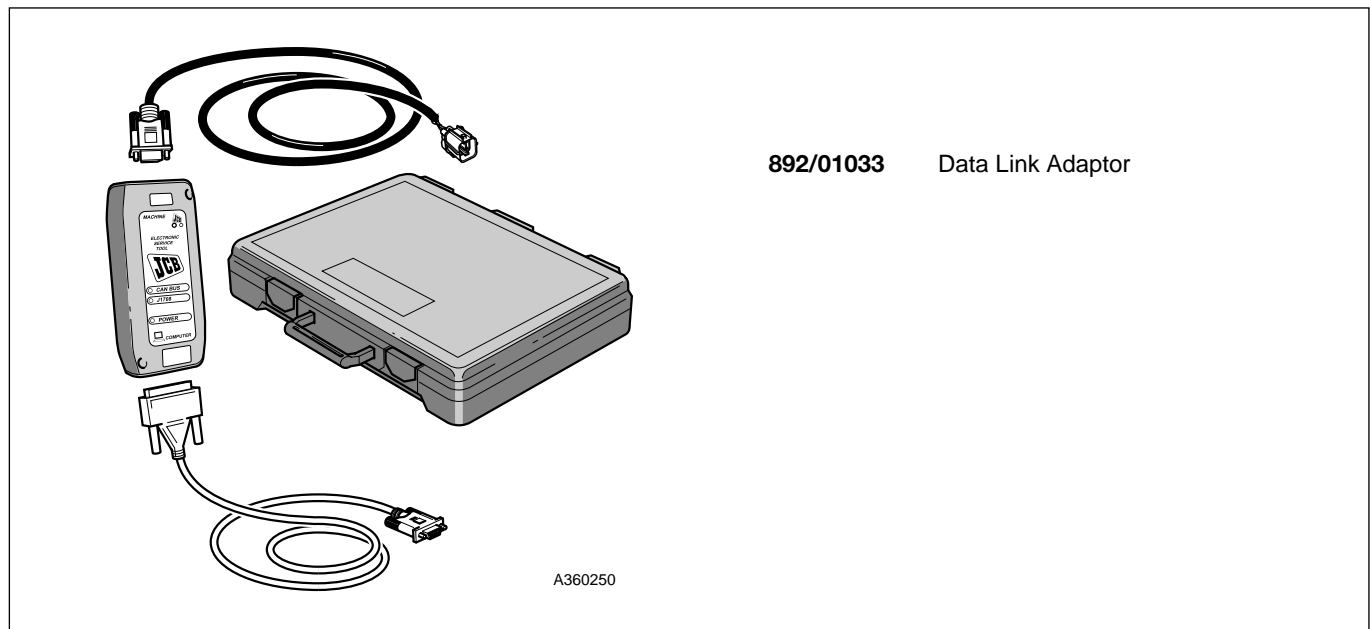
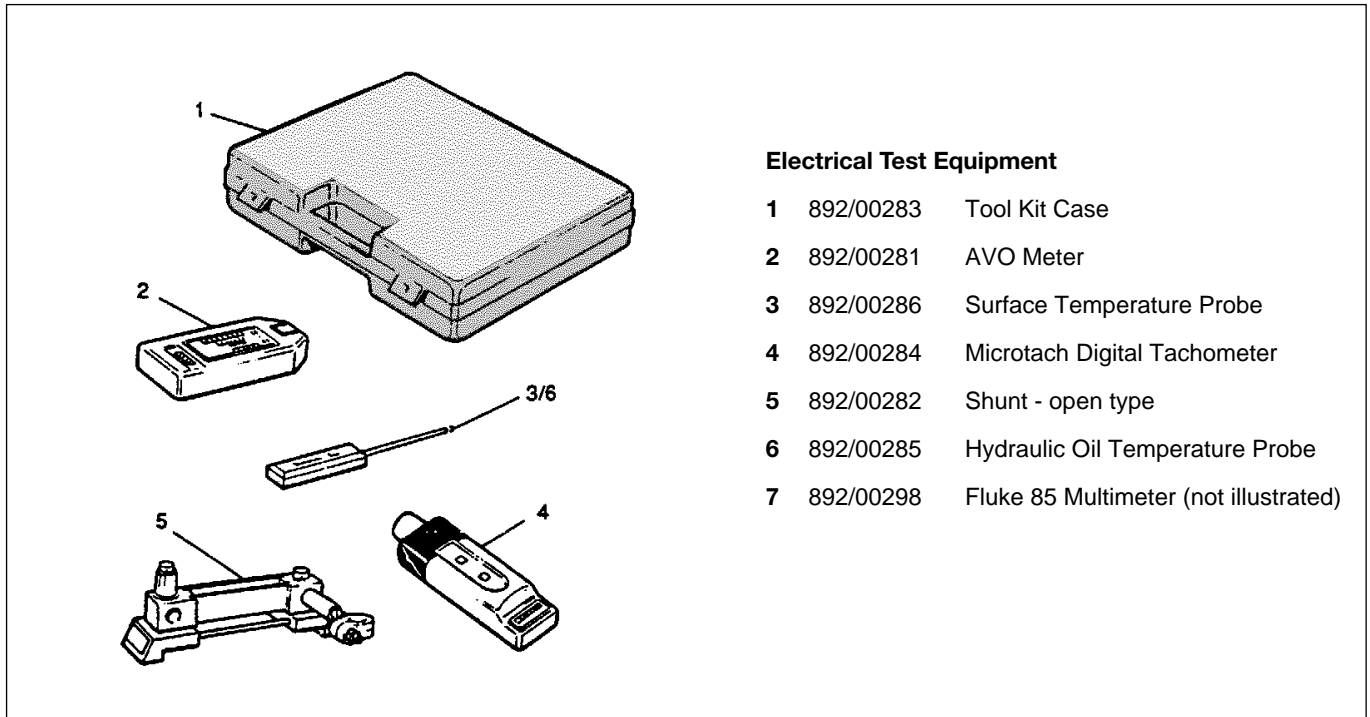

Service Tools (continued)

SECTION E - HYDRAULICS

Hydraulic Pressure Test Gauges and Connections

- 1 892/00346 Pressure Gauge 0-70 bar (0-1000 lbf/in²)
- 2 892/00898 Pressure Gauge 0-100 bar (0-1500 lbf/in²)
- 3 892/00279 Pressure Gauge 0-400 bar (0-6000 lbf/in²)
- 4 892/00280 Pressure Gauge 0-600 bar (0-8500 lbf/in²)
- 5 892/00347 Connector
- 6 892/00254 Hose

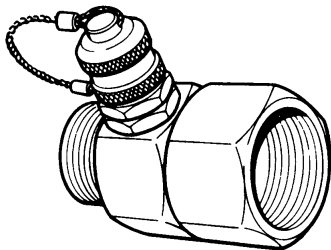
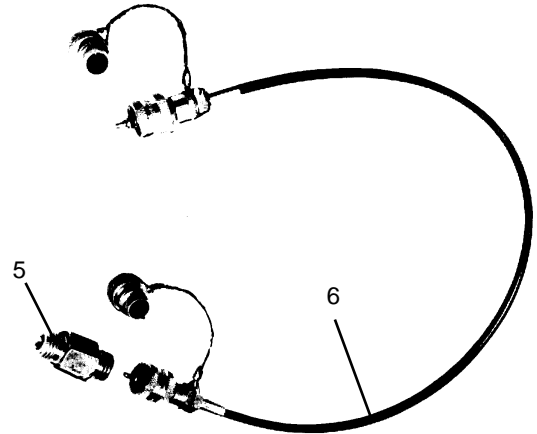
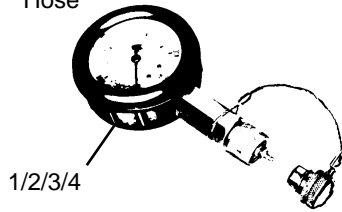

Pressure Test 'T' Adapters

- 892/00262 1/4 in BSP x 1/4 in F BSP x Test Point
- 816/55038 3/8 in BSP x 3/8 in F BSP x Test Point
- 816/55040 1/2 in BSP x 1/2 in F BSP x Test Point
- 892/00263 5/8 in BSP x 5/8 in F BSP x Test Point
- 892/00264 3/4 in BSP x 3/4 in F BSP x Test Point
- 892/00265 1 in M BSP x 1 in F BSP x Test Point
- 892/00266 1,1/4 in M BSP x 1,1/4 in F BSP x Test Point
- 892/00267 1,1/2 in M BSP x 1,1/2 in F BSP x Test Point

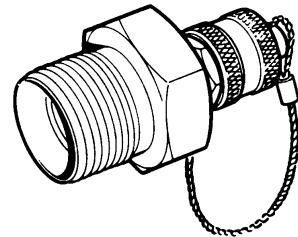

Pressure Test Adapters

- 892/00255 1/4 in BSP x Test Point
- 892/00256 3/8 in BSP x Test Point
- 892/00257 1/2 in BSP x Test Point
- 892/00258 5/8 in BSP x Test Point
- 816/15118 3/4 in BSP x Test Point
- 892/00259 1 in BSP x Test Point
- 892/00260 1,1/4 in BSP x Test Point
- 892/00261 5/8 in UNF x Test Point

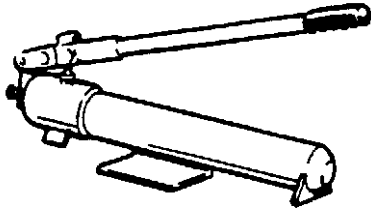
Service Tools (continued)**SECTION E - HYDRAULICS****Hand Pump Equipment**

892/00223	Hand Pump
892/00137	Micro-bore Hose 1/4 in BSP x 5 metres
892/00274	Adapter 1/4 in M BSP x 3/8 in M BSP Taper
892/00262	1/4 in M BSP x 1/4 in F BSP x Test Point
892/00706	Test Probe
892/00278	Gauge 0 - 40 bar (0 - 600 lb/in ²)
892/00279	Gauge 0 - 400 bar (0 - 6000 lb/in ²)
892/00280	Gauge 0 - 600 bar (0 - 8500 lb/in ²)

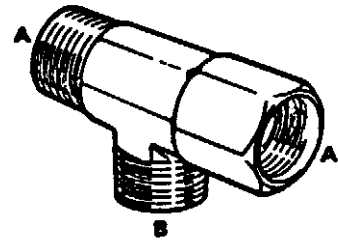

816/50005	1/2 in BSP (A) x 1/2 in BSP (B)
816/60096	3/4 in BSP (A) x 3/4 in BSP (B)
816/00018	1 in BSP (A) x 1 in BSP (B)

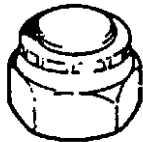
**Female Cone Blanking Plug**

892/00055	1/4 in BSP
892/00056	3/8 in BSP
892/00057	1/2 in BSP
892/00058	5/8 in BSP
892/00059	3/4 in BSP
892/00060	1 in BSP

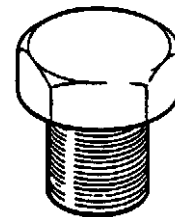
**Male Cone Blanking Plug**

816/00294	1/4 in BSP
816/00189	3/8 in BSP
816/00190	1/2 in BSP
816/00197	5/8 in BSP
816/00196	3/4 in BSP
816/00193	1 in BSP

Service Tools (continued)

SECTION E - HYDRAULICS

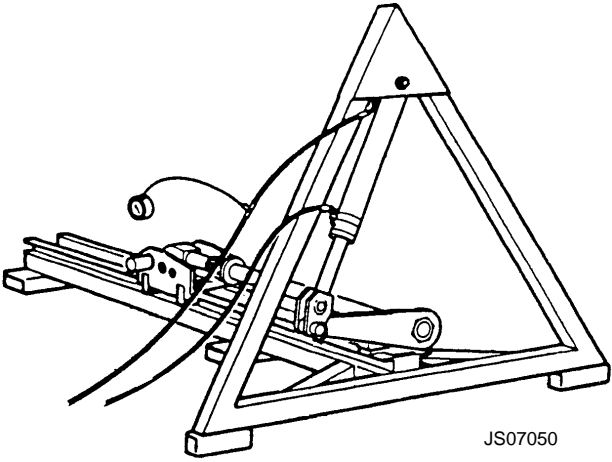

JS07050

Ram Piston Nut Removal/Fitting Rig

993/99525	Rig assembly (not including spanners and ram)
993/99522	Anchor Side Plate (supplied loose unwelded)
993/99523	Anchor cross Member (supplied loose unwelded)
993/99524	Ram Eye End Modification Plate Assembly
556/43400	Lift Ram
545/18000	Lynch Pin
811/50232	1,1/4 in. Pivot Pin

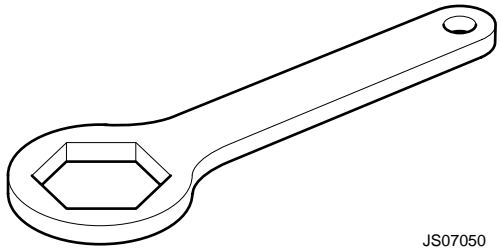

JS07050

JS07050

Ram Piston Nut Removal/Fitting Spanner

993/99512	Spanner 55mm A/F
993/99513	Spanner 60mm A/F
993/99514	Spanner 65mm A/F
993/99515	Spanner 70mm A/F
993/99516	Spanner 75mm A/F
993/99517	Spanner 85mm A/F
993/99518	Spanner 90mm A/F
993/99519	Spanner 100mm A/F
993/99520	Spanner 110mm A/F
993/99521	Spanner 115mm A/F
SSP0046	Spanner 80mm A/F
SSP0047	Spanner 95mm A/F

Sealing and Retaining Compounds

JCB Multi-Gasket	A medium strength sealant suitable for all sizes of gasket flanges, and for hydraulic fittings of 25-65 mm diameter.	4102/1212	50 ml
JCB Threadlocker	For threads of 50 mm diameter upwards, e.g. suction strainer.	4101/0451	50 ml
JCB Threadlocker (High Strength)	A high strength locking fluid for use with threaded components. Gasketing for all sizes of flange where the strength of the joint is important.	4102/0551	50 ml
JCB Retainer (High Strength)	For all retaining parts which are unlikely to be dismantled.	4101/0651	50 ml
JCB Threadlocker and Sealer	A medium strength locking fluid for sealing and retaining nuts, bolts, and screws up to 50 mm diameter, and for hydraulic fittings up to 25 mm diameter.	4101/0250 4101/0251	10 ml 50 ml
JCB Threadlocker and Sealer (High Strength)	A high strength locking fluid for sealing and retaining nuts, bolts, and screws up to 50 mm diameter, and for hydraulic fittings up to 25 mm diameter.	4101/0550 4101/0552	10 ml 200 ml
JCB Threadseal	A medium strength thread sealing compound.	4102/1951	50 ml
JCB Activator	A cleaning primer which speeds the curing rate of anaerobic products.	4104/0251 4104/0253	Aerosol (1 ltr) Bottle (200 ml)
JCB Cleaner/Degreaser	For degreasing components prior to use of anaerobic adhesives and sealants.	4104/1557	Aerosol (400 ml)
Anti-Seize Paste	A compound used for assembly and prevention of parts seizure.	4003/0211	
Direct Glazing Kit	For one pane of glass; comprises items marked † below plus applicator nozzle etc.		
† Ultra Fast Adhesive	For direct glazing	4103/2109	310 ml
† Active Wipe 205	For direct glazing	4104/1203	250 g
† Black Primer 206J	For direct glazing	4201/4906	30 ml
Clear Silicone Sealant	To seal butt jointed glass.	4102/0901	

Contents	Page No.
Safety Notices	1 - 1
General Safety	2 - 1
Operating Safety	3 - 1
Maintenance Safety	4 - 1

Buy Now



Our support email:

ebooklibonline@outlook.com