

# Brushcat™ Rotary Cutter

60 Inch  
72 Inch  
90 Inch



# Bobcat®

# Service Manual

60 Inch S/N 467002282 & Above  
60 Inch S/N 467200101 & Above  
60 Inch S/N A01900101 & Above  
60 Inch HF S/N A01A00101 & Above  
72 Inch S/N A00800101 & Above  
72 Inch HF S/N A01B00101 & Above  
72 Inch X S/N A01C00101 & Above  
90 Inch S/N 467100101 & Above

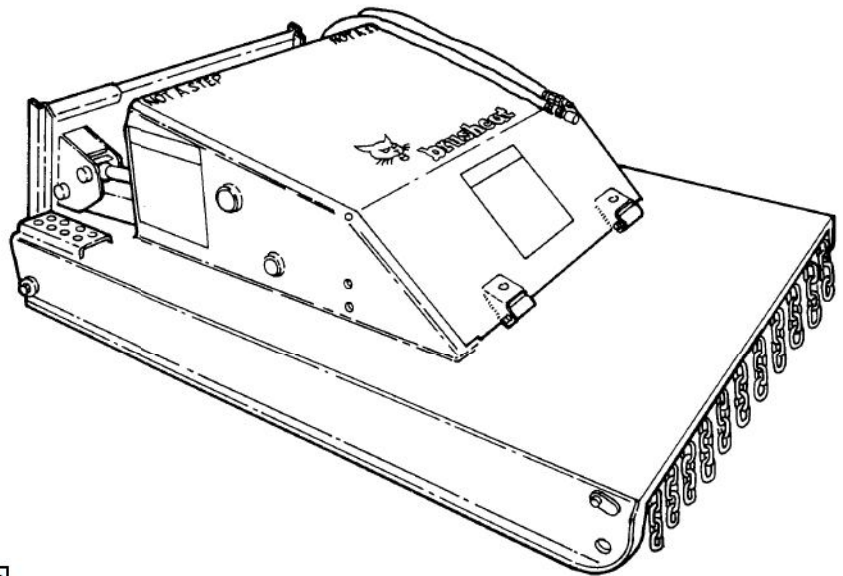

*Doosan purchased Bobcat Company from Ingersoll-Rand Company in 2007. Any reference to Ingersoll-Rand Company or use of trademarks, service marks, logos, or other proprietary identifying marks belonging to Ingersoll-Rand Company in this manual is historical or nominative in nature, and is not meant to suggest a current affiliation between Ingersoll-Rand Company and Bobcat Company or the products of either.*

# MAINTENANCE SAFETY



## WARNING







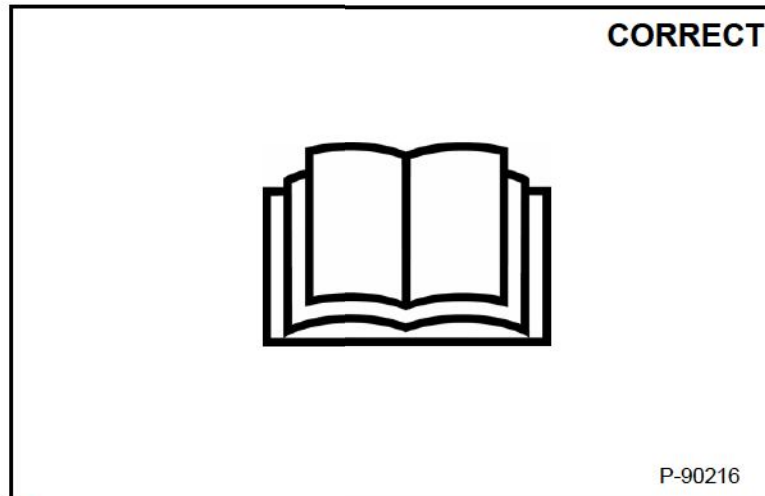

Instructions are necessary before operating or servicing machine. Read and understand the Operation & Maintenance Manual, Operator's Handbook and signs (decals) on machine. Follow warnings and instructions in the manuals when making repairs, adjustments or servicing. Check for correct function after adjustments, repairs or service. Untrained operators and failure to follow instructions can cause injury or death.

W-2003-0807



**Safety Alert Symbol:** This symbol with a warning statement, means: "Warning, be alert! Your safety is involved!" Carefully read the message that follows.



-  Never service attachments / implements without instructions. See Operation & Maintenance Manual and Attachment / Implement Service Manual.
-  Cleaning and maintenance are required daily.
-  Never service or adjust attachment / implement with the engine running unless instructed to do so in manual.
-  Always lower the attachment / implement to the ground before lubricating or servicing.
-  Avoid contact with leaking hydraulic fluid or diesel fuel under pressure. It can penetrate skin or eyes.
-  Stop, cool and clean engine of flammable materials before checking fluids.
-  Keep body, loose objects and clothing away from moving parts, electrical contacts, hot parts and exhaust.
-  Safety glasses are needed for eye protection from electrical arcs, battery acid, compressed springs, fluids under pressure and flying debris or when tools are used. Use eye protection approved for type of welding.

## ALPHABETICAL INDEX

ADJUSTING THE COVER LATCH (S/N 467002282 & ABOVE, 467200101 & ABOVE AND 467100101 & ABOVE) .....	30-01
AUXILIARY HYDRAULIC PRESSURE GAUGE.....	20-01
BLADE .....	30-01
BRUSHCAT ROTARY CUTTER SERVICE.....	10-01
CHAIN SHIELD.....	30-01
GEARBOX 60 INCH (S/N 46702282 & ABOVE AND 467200101 & ABOVE) .....	30-01
GEARBOX 60 AND 72 INCH (S/N A01900101 & ABOVE, A01A00101 & ABOVE, A00800101 & ABOVE, A01B00101 & ABOVE AND A01C00101 & ABOVE) .....	30-01
GEARBOX 60 INCH (S/N 46702282 & ABOVE AND 467200101 & ABOVE) .....	30-01
GEARBOX 90 INCH .....	30-01
GLOSSARY OF HYDRAULIC SYMBOLS FOR ATTACHMENTS .....	SPEC-01
HYDRAULIC CONTROL VALVE (S/N 467200101 & ABOVE, 467002282 & ABOVE AND 467100101 & ABOVE).....	20-01
HYDRAULIC FLOW INFORMATION .....	20-01
HYDRAULIC MOTOR (S/N 467002282 & ABOVE, 467200101 & ABOVE AND 467100101 & ABOVE).....	20-01
HYDRAULIC SCHEMATIC .....	SPEC-01
INSPECTION .....	10-01
LUBRICATION .....	10-01
MOUNT (S/N 467002282 & ABOVE, 467200101 & ABOVE AND 467100101 & ABOVE).....	30-01
MOUNTING FRAME (S/N A01900101 & ABOVE, A00800101 & ABOVE, A00800101 & ABOVE, A01B00101 & ABOVE AND A01C00101 & ABOVE) .....	30-01
POWER TAKE OFF SHAFT .....	30-01
RELIEF VALVE (S/N 467200101 & ABOVE, 467002282 & ABOVE AND 467100101 & ABOVE).....	20-01
ROD (S/N 467002282 & ABOVE, 467200101 & ABOVE AND 467100101 & ABOVE).....	30-01
ROLLER.....	30-01
SPECIFICATIONS .....	SPEC-01
SPRING CYLINDER (S/N A00800101 & ABOVE, A01900101 & ABOVE, A01A00101 & ABOVE, A01B00101 & ABOVE AND A01C00101 & ABOVE).....	30-01
TROUBLESHOOTING.....	10-01

Dealer Copy -- Not for Resale

# CONTENTS

SERIAL NUMBER LOCATIONS .....	III
DELIVERY REPORT .....	III
BRUSHCAT ROTARY CUTTER IDENTIFICATION .....	IV
SAFETY & MAINTENANCE .....	10-01
HYDRAULIC SYSTEM .....	20-01
MAIN FRAME .....	30-01
SPECIFICATIONS .....	SPEC-01

**SAFETY &  
MAINTENANCE**

**HYDRAULIC  
SYSTEM**

**MAIN FRAME**

**SPECIFICATION**

Dealer Copy -- Not for Resale

**CALIFORNIA  
PROPOSITION 65 WARNING**  
Diesel engine exhaust and some of its  
constituents are known to the State of California  
to cause cancer, birth defects and other  
reproductive harm.

## SERIAL NUMBER LOCATIONS

Always use the serial number of the Brushcat Rotary Cutter when requesting service information or when ordering parts. Early or later models (identification made by serial number) may use different parts, or it may be necessary to use a different procedure in doing a specific service operation.

**Brushcat Rotary Cutter Serial Number (S/N 467002282 & Above, 467200101 & Above and 467100101 & Above)**

Figure 1



The Brushcat Rotary Cutter serial number plate (Item 1) [Figure 1] is located on the center of the front frame.

**Brushcat Rotary Cutter Serial Number (SN A00800101 & Above, A01900101 & Above, A01A00101 & Above, A01B00101 & Above And A01C00101 & Above)**

Figure 2

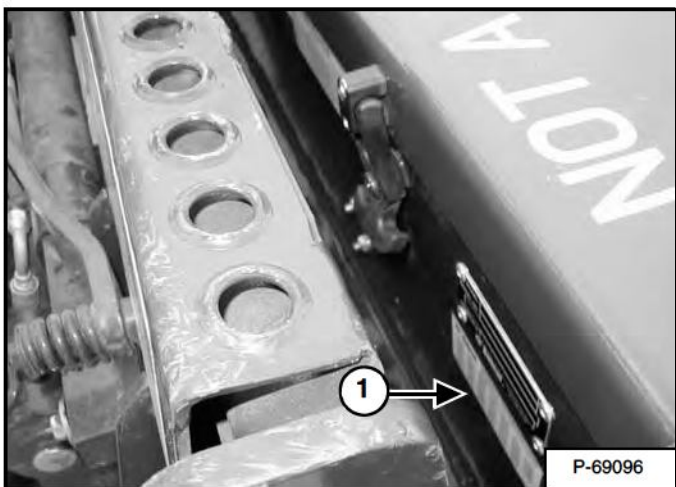

The Brushcat Rotary Cutter serial number plate (Item 1) [Figure 2] is located on the center of the front frame.

## DELIVERY REPORT

Figure 3

A diagram of a delivery report form. The form is divided into several sections. At the top right is a section titled 'DELIVERY REPORT' with several lines of text. Below this is a section titled 'WARNING' with a large 'X' over it. The form is labeled 'B-16315' in the bottom right corner.

The delivery report must be filled out by the dealer and signed by the owner or operator when the Bobcat Brushcat Rotary Cutter is delivered. An explanation of the form must be given to the owner. Make sure it is filled out completely [Figure 3].

Dealer Copy -- Not for Resale

## BRUSHCAT ROTARY CUTTER IDENTIFICATION

60 Inch (S/N 46700282 & Above And 467200101 & Above) And 90 Inch (S/N 467100101 & Above)

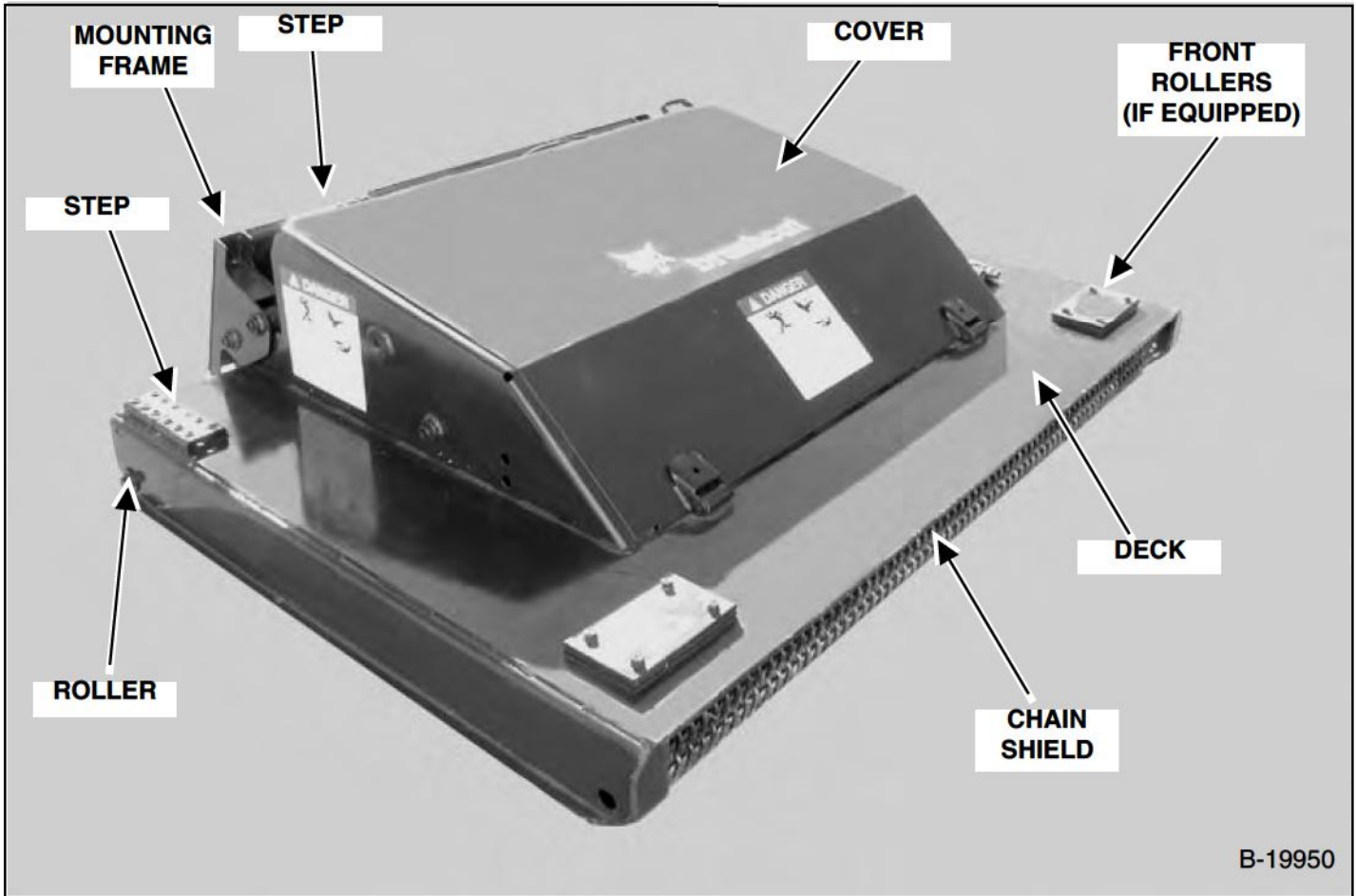

Dealer Copy -- Not for Resale

**BRUSHCAT ROTARY CUTTER IDENTIFICATION (CONT'D)**

**60 Inch (S/N A01900101 & Above And A01A00101 & Above) 72 Inch (S/N A00800101 & Above, A01B00101 & Above and A01C00101 & Above)**

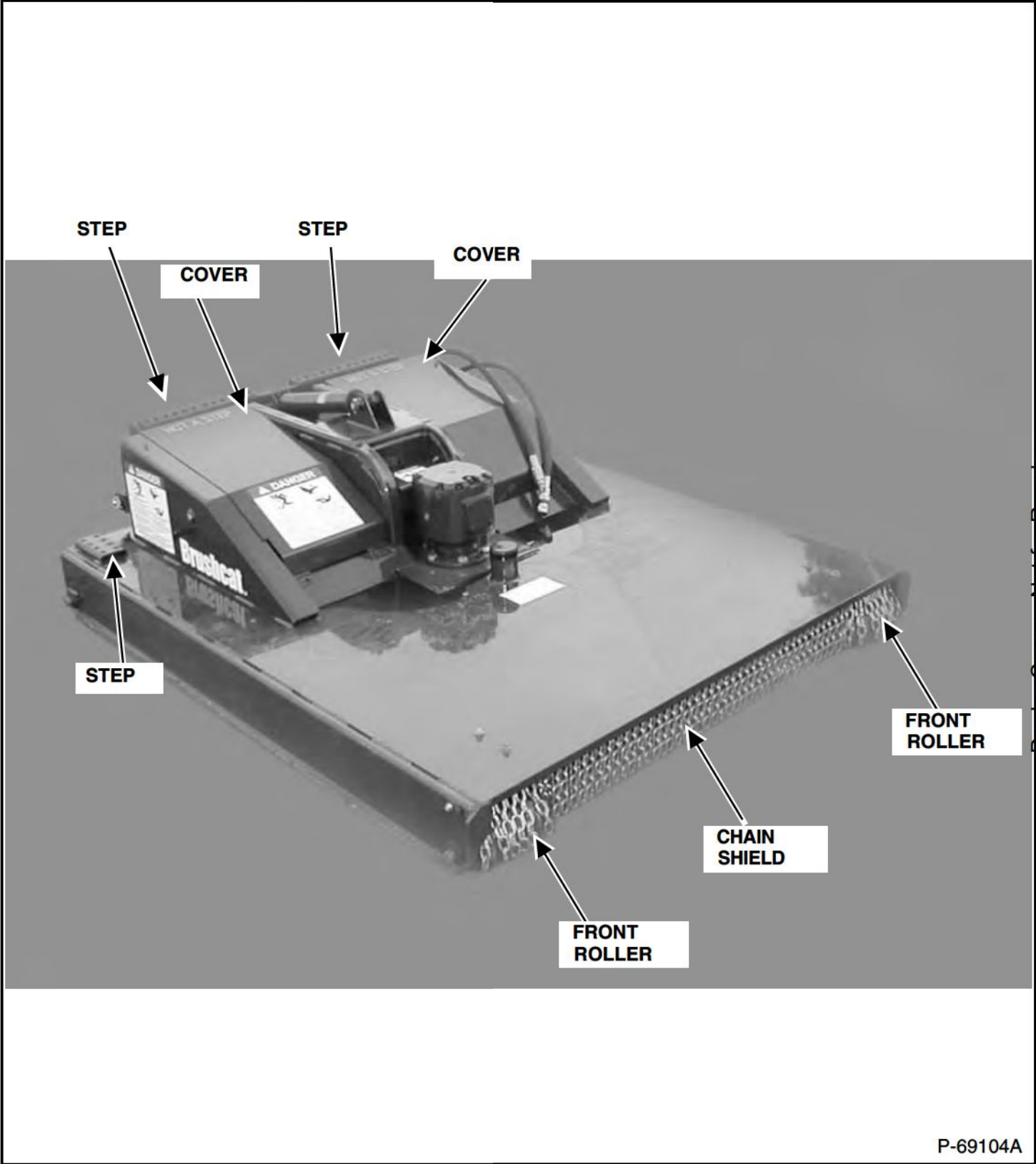

Dealer Copy -- Not for Resale

**BRUSHCAT ROTARY CUTTER IDENTIFICATION (CONT'D)**

60 Inch (S/N A01900101 & Above And A01A00101 & Above) 72 Inch (S/N A00800101 & Above, A01B00101 & Above and A01C00101 & Above)

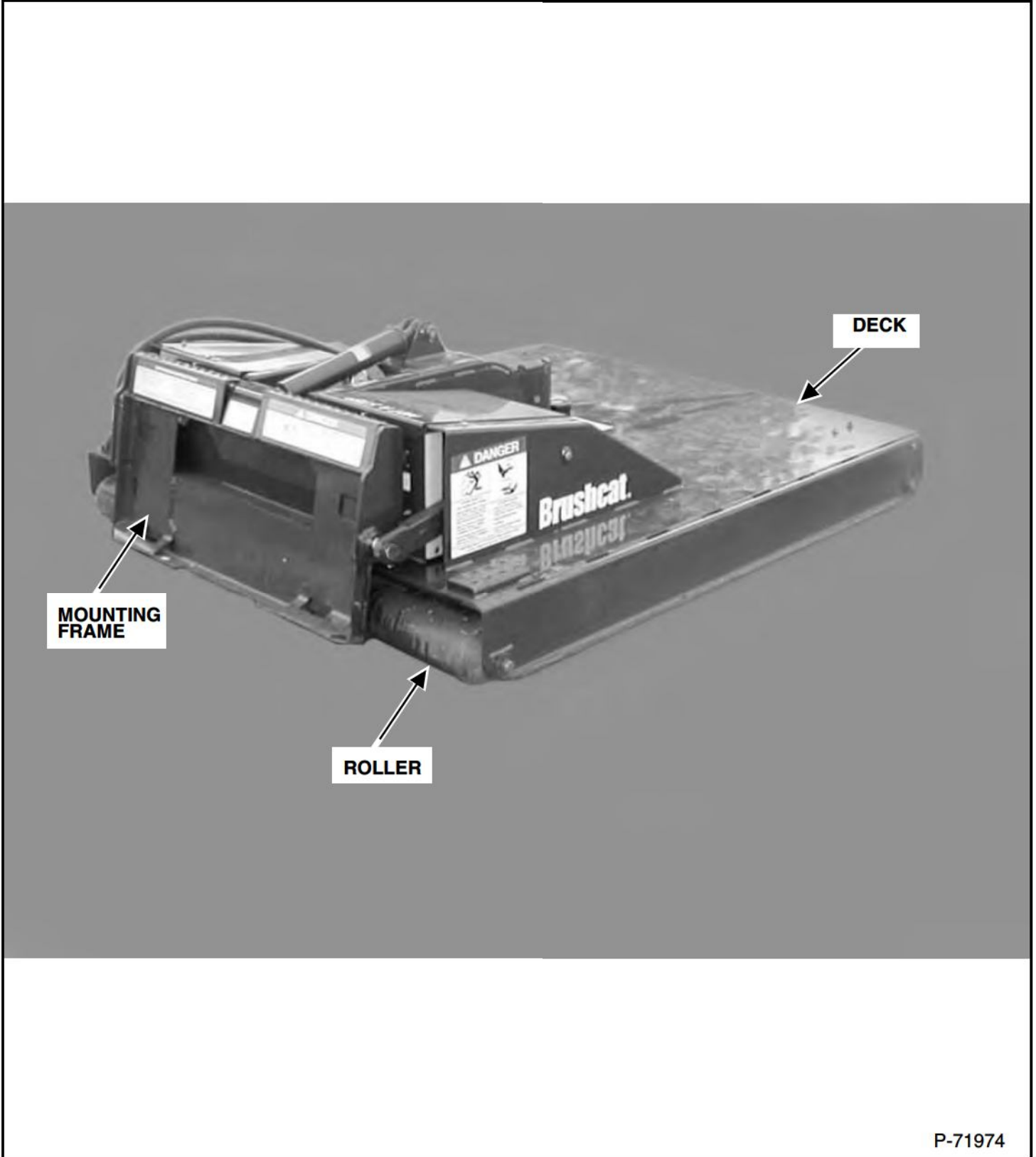

Dealer Copy -- Not for Resale

P-71974



BRUSHCAT ROTARY CUTTER SERVICE..... 10-30-1  
Blade Removal And Installation..... 10-30-3  
Chain Shield Removal And Installation..... 10-30-5  
Cleaning The Rotary Cutter (S/N 467002282 & Above, 467200101 & Above And 467100101 & Above)..... 10-30-1  
Cleaning The Rotary Cutter (S/N A01900101 & Above, A01A00101 & Above, A00800101 & Above, A01B00101 & Above And A01C00101 & Above)..... 10-30-3

INSPECTION..... 10-20-1  
Checking The Mechanical Linkage And The Blade Shut-Off Device..... 10-10-6  
Daily Inspection..... 10-20-5  
Hand Lever Bob-Tach Inspection..... 10-20-1  
Power Bob-Tach Inspection..... 10-20-2  
Rotary Cutter Inspection..... 10-20-4

LUBRICATION..... 10-40-1  
Lubrication Points (60 Inch Rotary Cutter) (S/N 467002282 & Above And 467200101 & Above)..... 10-40-1  
Lubrication Points (60 Inch Rotary Cutter S/N A01900101 & Above, A01A00101 & Above And 72 Inch Rotary Cutter S/N A00800101 & Above, A01800101 & Above And A01C00101 & Above)..... 10-40-5  
Lubrication Points (90 Inch Rotary Cutter) (S/N 467100101 & Above)..... 10-40-2

TROUBLESHOOTING..... 10-10-1

Dealer Copy -- Not for Resale

**TROUBLESHOOTING**



**AVOID INJURY OR DEATH**

Instructions are necessary before operating or servicing machine. Read and understand the Operation & Maintenance Manual, Operator's Handbook and signs (decals) on machine. Follow warnings and instructions in the manuals when making repairs, adjustments or servicing. Check for correct function after adjustments, repairs or service. Untrained operators and failure to follow instructions can cause injury or death.

W-2003-0807

<b>PROBLEM</b>	<b>CAUSE</b>	<b>CORRECTION</b>
Poor cutting.	Travel speed too fast.	Reduce travel speed.
	Debris on blade mounting plate.	Clean mounting plate.
	Damaged cutter motor.	Repair or replace motor.
	Low blade RPM.	Check auxiliary flow and pressure.
Blades will not stop when shut-off lever is engaged.	Linkage broken.	Replace linkage.
	Internal damage to valve.	Repair or replace valve.
Excessive vibration.	Build up of material on the blade mounting plate.	Clean mounting plate.
	Blades not swinging freely.	Check blades for obstructions.
	Loose or cracked hardware.	Repair or replace as needed.
	Blades worn or broken.	Replace both blades.
	Damaged angle drive.	Repair or replace angle drive.
Blades will not rotate.	Lift arms too high.	Lower lift arms and activate the auxiliary hydraulics.
	Loader fluid level too low.	Add hydraulic fluid to the fluid reservoir on the loader.
	Damaged hydraulic hoses.	Repair or replace hoses.
	Damaged quick coupler(s).	Replace quick coupler(s).
	Drive coupler slipping.	Check screws, bolt and nut, and key in drive coupler.
	Blade shut-off linkage broken or missing.	Repair or replace as needed.
	Internal damage to valve.	Repair or replace valve.
	Loader main relief valve set too low.	Adjust main relief valve to correct setting.

Dealer Copy -- Not for Resale

**Buy Now**



Our support email:

[ebooklibonline@outlook.com](mailto:ebooklibonline@outlook.com)