

Brush Saw



Bobcat®

Service Manual

S/N A13P00101 & Above

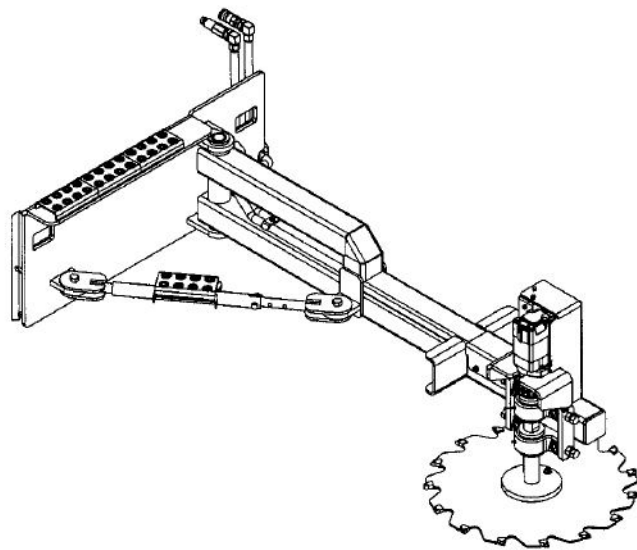

Doosan purchased Bobcat Company from Ingersoll-Rand Company in 2007. Any reference to Ingersoll-Rand Company or use of trademarks, service marks, logos, or other proprietary identifying marks belonging to Ingersoll-Rand Company in this manual is historical or nominative in nature, and is not meant to suggest a current affiliation between Ingersoll-Rand Company and Bobcat Company or the products of either.

MAINTENANCE SAFETY



WARNING







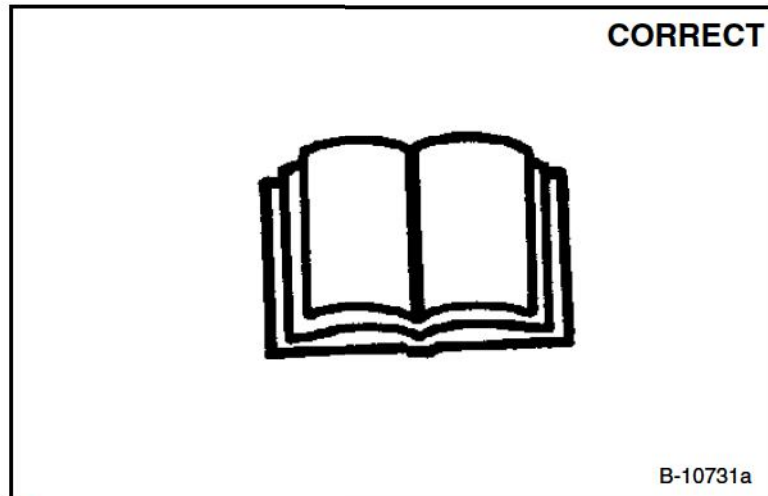

Instructions are necessary before operating or servicing machine. Read and understand the Operation & Maintenance Manual, Operator's Handbook and signs (decals) on machine. Follow warnings and instructions in the manuals when making repairs, adjustments or servicing. Check for correct function after adjustments, repairs or service. Untrained operators and failure to follow instructions can cause injury or death.

W-2003-0903



Safety Alert Symbol: This symbol with a warning statement, means: "Warning, be alert! Your safety is involved!" Carefully read the message that follows.



-  Never service attachments without instructions. See Operation & Maintenance Manual and Attachment Service Manual.
-  Cleaning and maintenance are required daily.
-  Never service or adjust attachment with the engine running unless instructed to do so in manual.
-  Always lower the attachment to the ground before lubricating or servicing.
-  Avoid contact with leaking hydraulic fluid or diesel fuel under pressure. It can penetrate skin or eyes.
-  Stop, cool and clean engine of flammable materials before checking fluids.
-  Keep body, loose objects and clothing away from moving parts, electrical contacts, hot parts and exhaust.
-  Safety glasses are needed for eye protection from electrical arcs, battery acid, compressed springs, fluids under pressure and flying debris or when tools are used. Use eye protection approved for type of welding.

ALPHABETICAL INDEX

ATTACHMENT DELIVERY REPORT	III
BOOM LINK	30-01
DISC	30-01
HYDRAULIC MOTOR	20-01
HYDRAULIC SCHEMATIC	SPEC-01
IDENTIFICATION AND MACHINE SIGNS (DECALS)..IV	
INSPECTION	10-01
LUBRICATION	10-01
SERIAL NUMBER LOCATIONS	III
SHAFT ASSEMBLY	30-01
SPECIFICATIONS	SPEC-01
TROUBLESHOOTING	10-01

Dealer Copy -- Not for Resale

CONTENTS

**SAFETY &
MAINTENANCE**

**HYDRAULIC
SYSTEM**

MAIN FRAME

SPECIFICATION

SERIAL NUMBER LOCATIONS	III
ATTACHMENT DELIVERY REPORT	III
IDENTIFICATION AND MACHINE SIGNS (DECALS)	IV
SAFETY & MAINTENANCE	10-01
HYDRAULIC SYSTEM	20-01
MAIN FRAME	30-01
SPECIFICATIONS	SPEC-01

Dealer Copy -- Not for Resale

**CALIFORNIA
PROPOSITION 65 WARNING**

Diesel engine exhaust and some of its constituents are known to the State of California to cause cancer, birth defects and other reproductive harm.

SERIAL NUMBER LOCATIONS

Always use the serial number of the Brush Saw when requesting service information or when ordering parts. Early or later models (identification made by serial number) may use different parts, or it may be necessary to use a different procedure in doing a specific service operation.

Figure 1

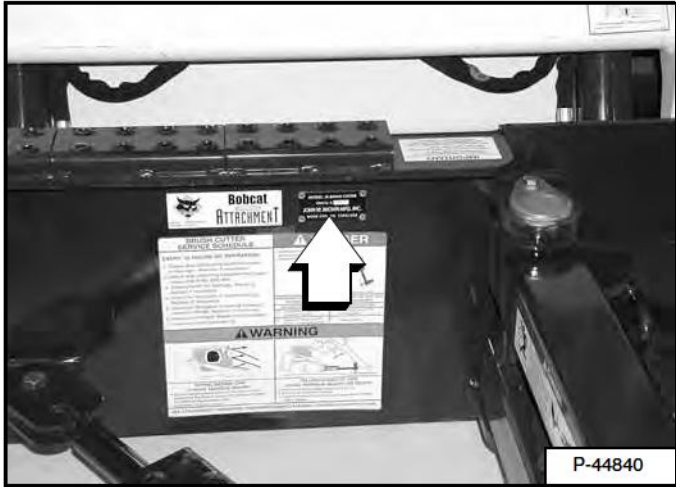

The serial number plate is located at the front of the frame [Figure 1].

ATTACHMENT DELIVERY REPORT

Figure 2

The delivery report must be filled out by the dealer and signed by the owner or operator when the Brush Saw is delivered. An explanation of the form must be given to the owner. Make sure it is filled out completely [Figure 2].

Dealer Copy -- Not for Resale

IDENTIFICATION AND MACHINE SIGNS (DECALS)

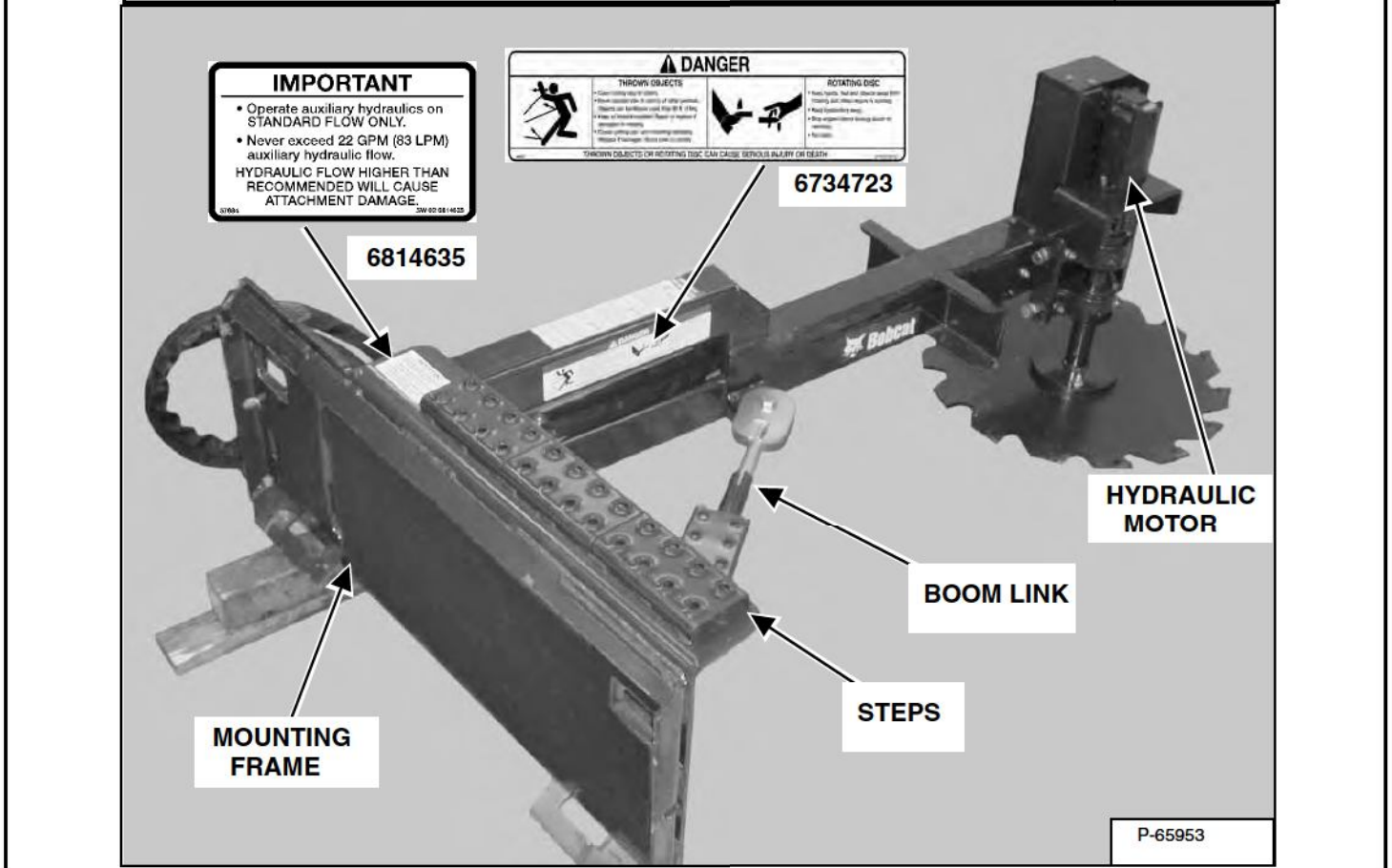
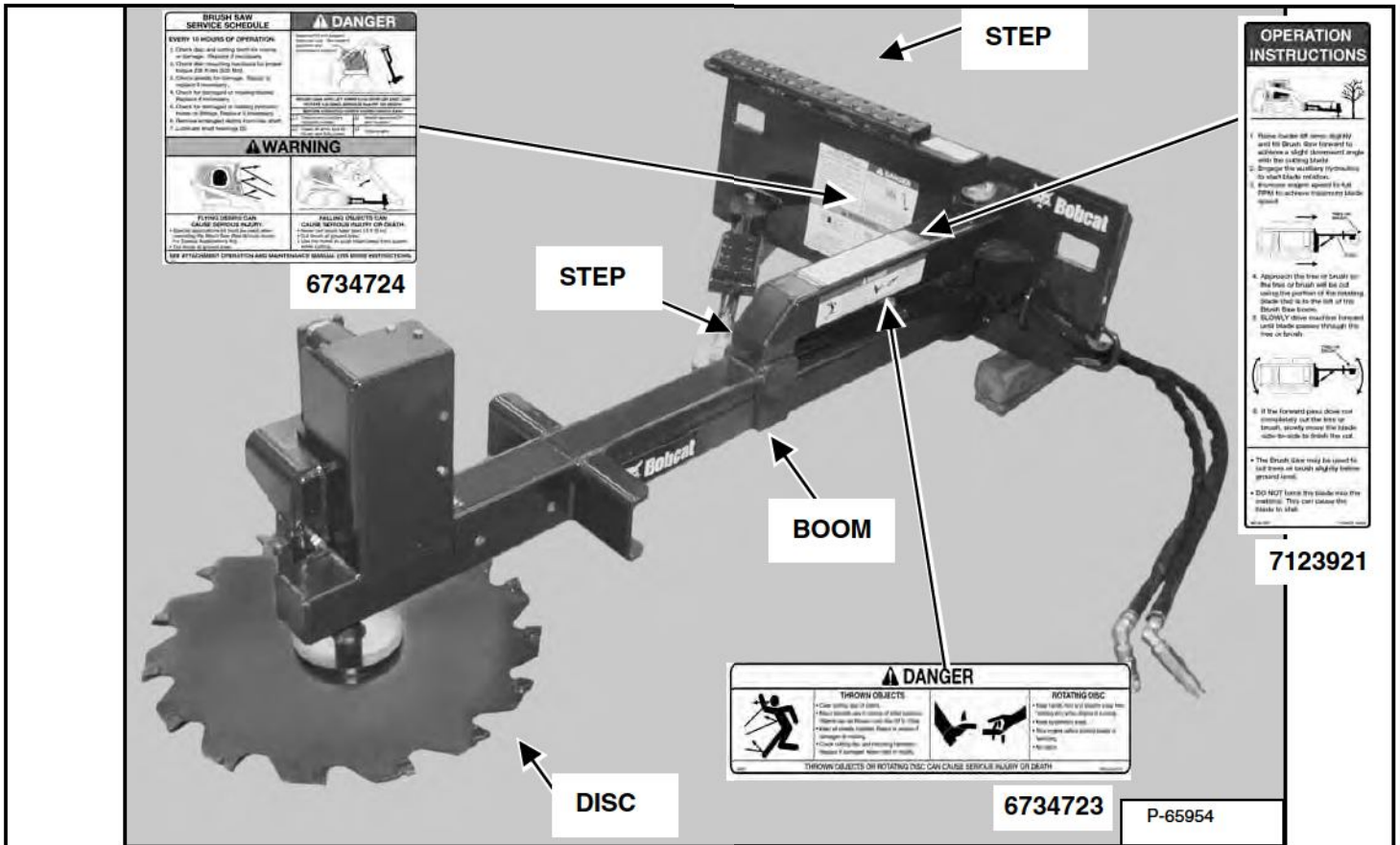

Dealer Copy -- Not for Resale

SAFETY & MAINTENANCE

LUBRICATION	10-20-1
INSPECTION	10-30-1
Hand Lever Bob-Tach Inspection.....	10-30-1
Power Bob-Tach Inspection.....	10-30-2
Attachment Mount Inspection	10-30-3
TROUBLESHOOTING	10-10-1

Dealer Copy -- Not for Resale

TROUBLESHOOTING

If the attachment is not working correctly, check the hydraulic system of the Loader thoroughly before making any repairs on the attachment. Attachment problems can be affected by a hydraulic system that is not operating to specifications or such problems as a plugged fuel filter or hydraulic filter in the Loader. Connect a flow meter to the Loader to check the hydraulic pump output, relief valve setting and tubelines to check flow and pressure. (See the Loader Service Manual for the correct procedure to connect the flow meter.)

WARNING

Instructions are necessary before operating or servicing machine. Read and understand the Operation & Maintenance Manual, Handbook and signs (decals) on machine. Follow warnings and instructions in the manuals when making repairs, adjustments or servicing. Check for correct function after adjustments, repairs or service. Untrained operators and failure to follow instructions can cause injury or death.

W-2003-0199

PROBLEM	CAUSE	CORRECTION
Poor cutting.	Travel speed too fast.	Reduce travel speed.
	Damaged motor	Repair or replace motor.
	Low disc RPM.	Check auxiliary flow and pressure.
	Worn, damaged or missing cutting teeth.	Replace cutting teeth.
Disc will not rotate.	Loader fluid level too low.	Add hydraulic fluid to the fluid reservoir on the loader.
	Damaged quick couplers.	Replace quick couplers.
	Damaged hydraulic hoses.	Repair or replace hoses.
	Loader main relief valve set too low.	Adjust main relief valve to correct setting.
Vibration.	Loose or cracked hardware.	Repair or replace as needed.
	Disc worn or broken.	Replace the disc.
	Disc spindle bent.	Replace spindle.

Dealer Copy -- Not for Resale

Buy Now



Our support email:

ebooklibonline@outlook.com