

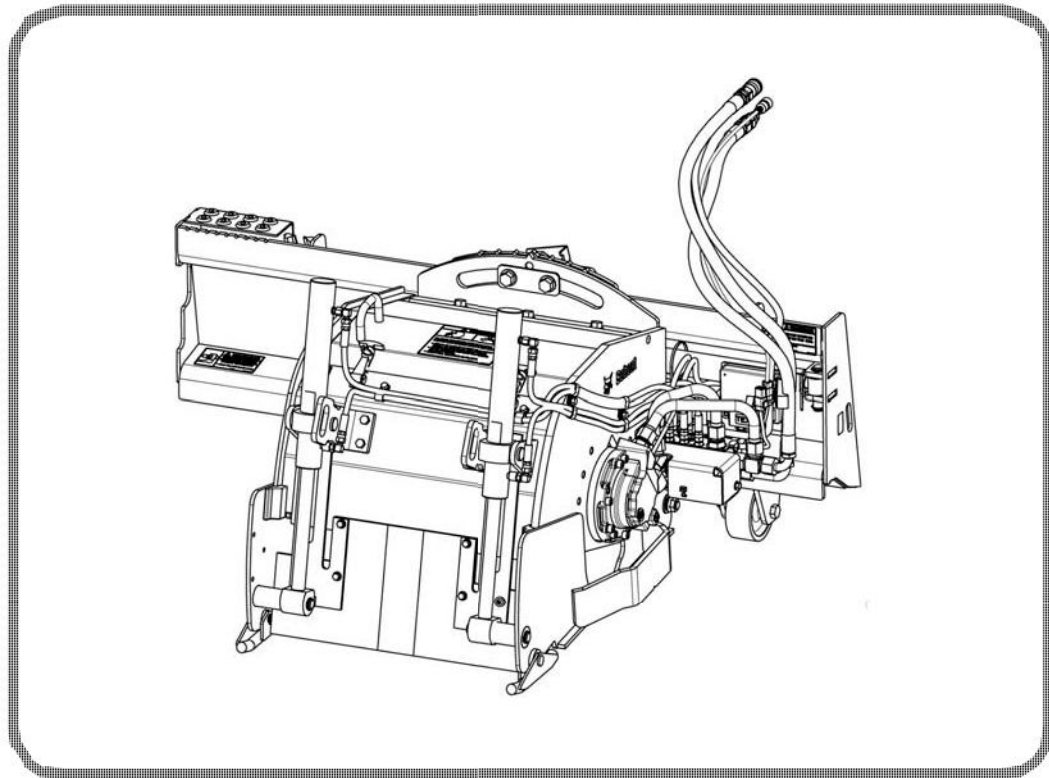

Bobcat®

Service Manual Planer

(18PLA) S/N AKS200101 & Above
(24PLA) S/N AJN700101 & Above
(PNSFL) S/N AKS300101 & Above



Dealer Copy -- Not for Resale



MAINTENANCE SAFETY



WARNING







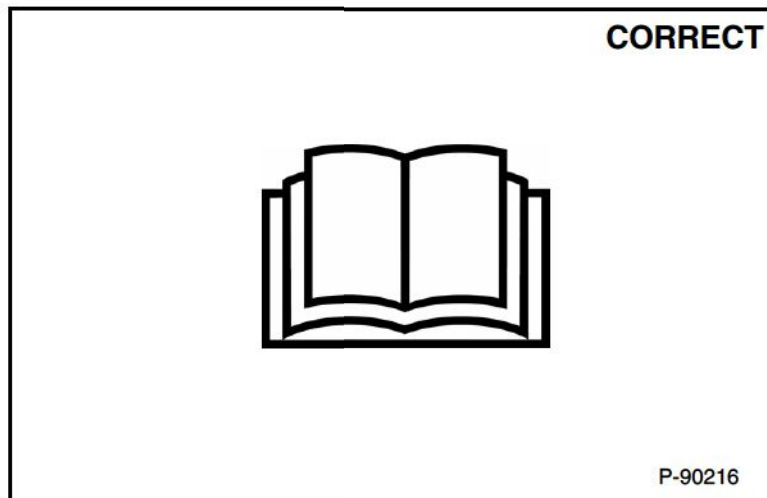

Instructions are necessary before operating or servicing machine. Read and understand the Operation & Maintenance Manual, Operator's Handbook and signs (decals) on machine. Follow warnings and instructions in the manuals when making repairs, adjustments or servicing. Check for correct function after adjustments, repairs or service. Untrained operators and failure to follow instructions can cause injury or death.

W-2003-0807



Safety Alert Symbol: This symbol with a warning statement, means: "Warning, be alert! Your safety is involved!" Carefully read the message that follows.



-  **Never service attachments / implements without instructions. See Operation & Maintenance Manual and Attachment / Implement Service Manual.**
-  **Cleaning and maintenance are required daily.**
-  **Never service or adjust attachment / implement with the engine running unless instructed to do so in manual.**
-  **Always lower the attachment / implement to the ground before lubricating or servicing.**
-  **Avoid contact with leaking hydraulic fluid or diesel fuel under pressure. It can penetrate skin or eyes.**
-  **Stop, cool and clean engine of flammable materials before checking fluids.**
-  **Keep body, loose objects and clothing away from moving parts, electrical contacts, hot parts and exhaust.**
-  **Safety glasses are needed for eye protection from electrical arcs, battery acid, compressed springs, fluids under pressure and flying debris or when tools are used. Use eye protection approved for type of welding.**

Dealer Copy -- Not for Resale

MSW30-0409

CONTENTS

SAFETY AND MAINTENANCE	10-01
HYDRAULIC SYSTEM	20-01
MAINFRAME	30-01
SPECIFICATIONS	SPEC-01
ALPHABETICAL INDEX	INDEX-01

Dealer Copy -- Not for Resale

FOREWORD

SERIAL NUMBER LOCATION	1-7
Attachment Serial Number	1-7
DELIVERY REPORT	1-7
ATTACHMENT IDENTIFICATION	1-8
(PNSFL) Planer	1-8
(18PLA And 24PLA) Planer	1-9

SERIAL NUMBER LOCATION

Attachment Serial Number

Figure 1

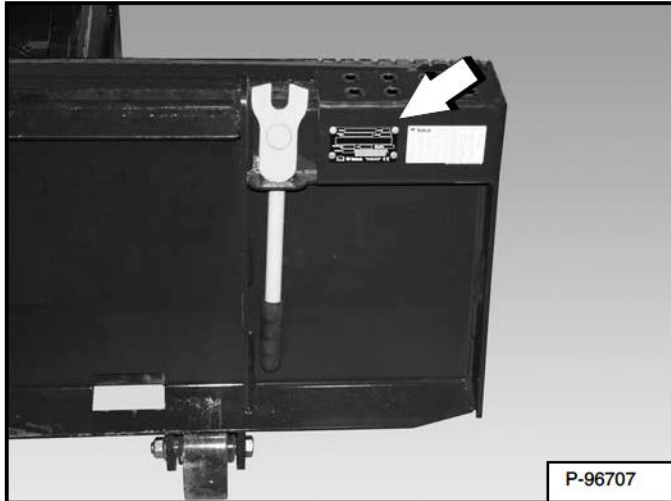

Always use the serial number **[Figure 1]** of the planer when requesting service information or when ordering parts. Early or later models (identification made by serial number) may use different parts, or it may be necessary to use a different procedure in doing a specific service operation.

DELIVERY REPORT

Figure 2

The delivery report **[Figure 2]** must be completed by the dealer and signed by the owner or operator when the Bobcat planer is delivered. An explanation of the form must be given to the owner.

Dealer Copy -- Not for Resale

ATTACHMENT IDENTIFICATION

(PNSFL) Planer

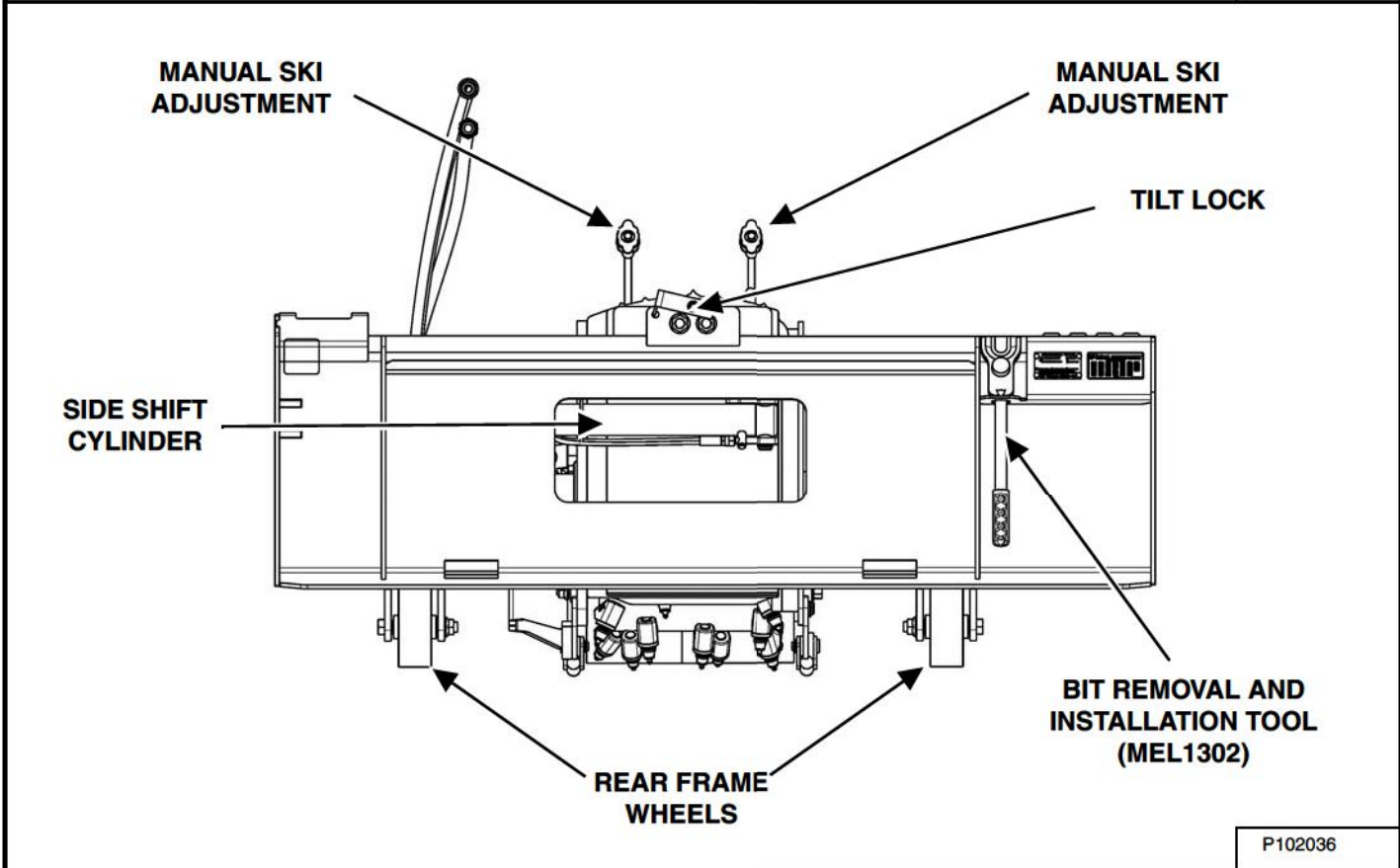
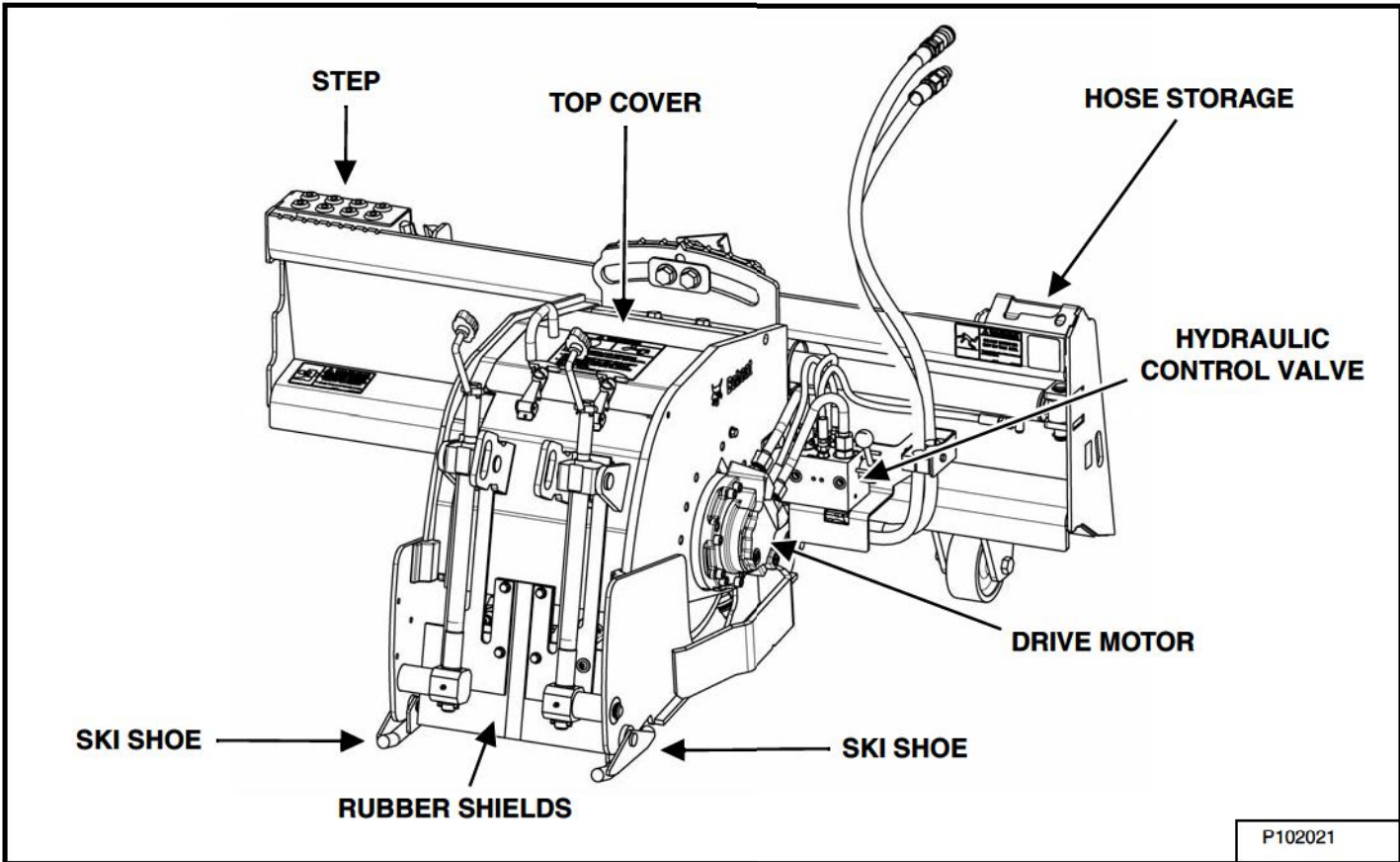

Dealer Copy -- Not for Resale

ATTACHMENT IDENTIFICATION (CONT'D)

(18PLA And 24PLA) Planer

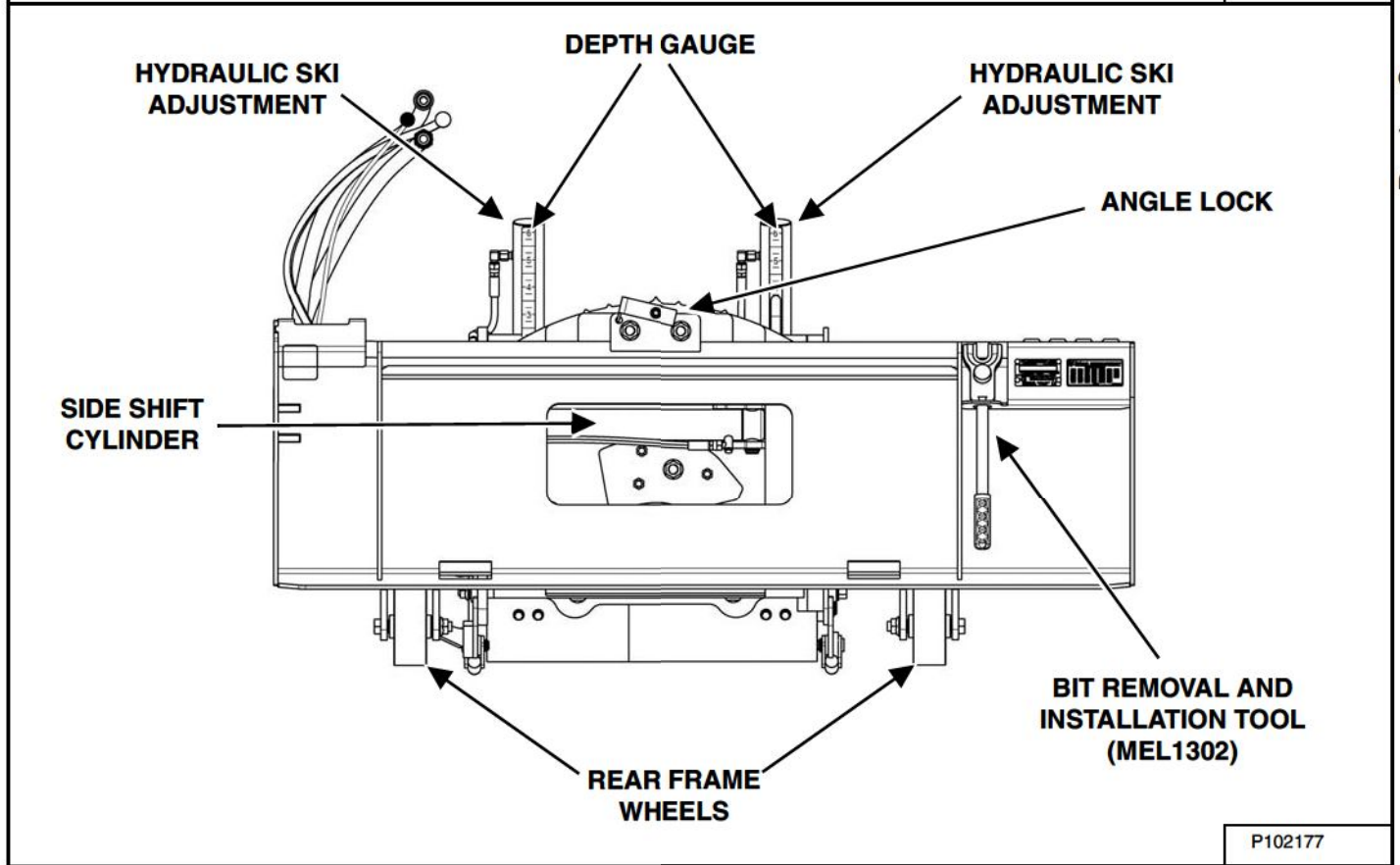
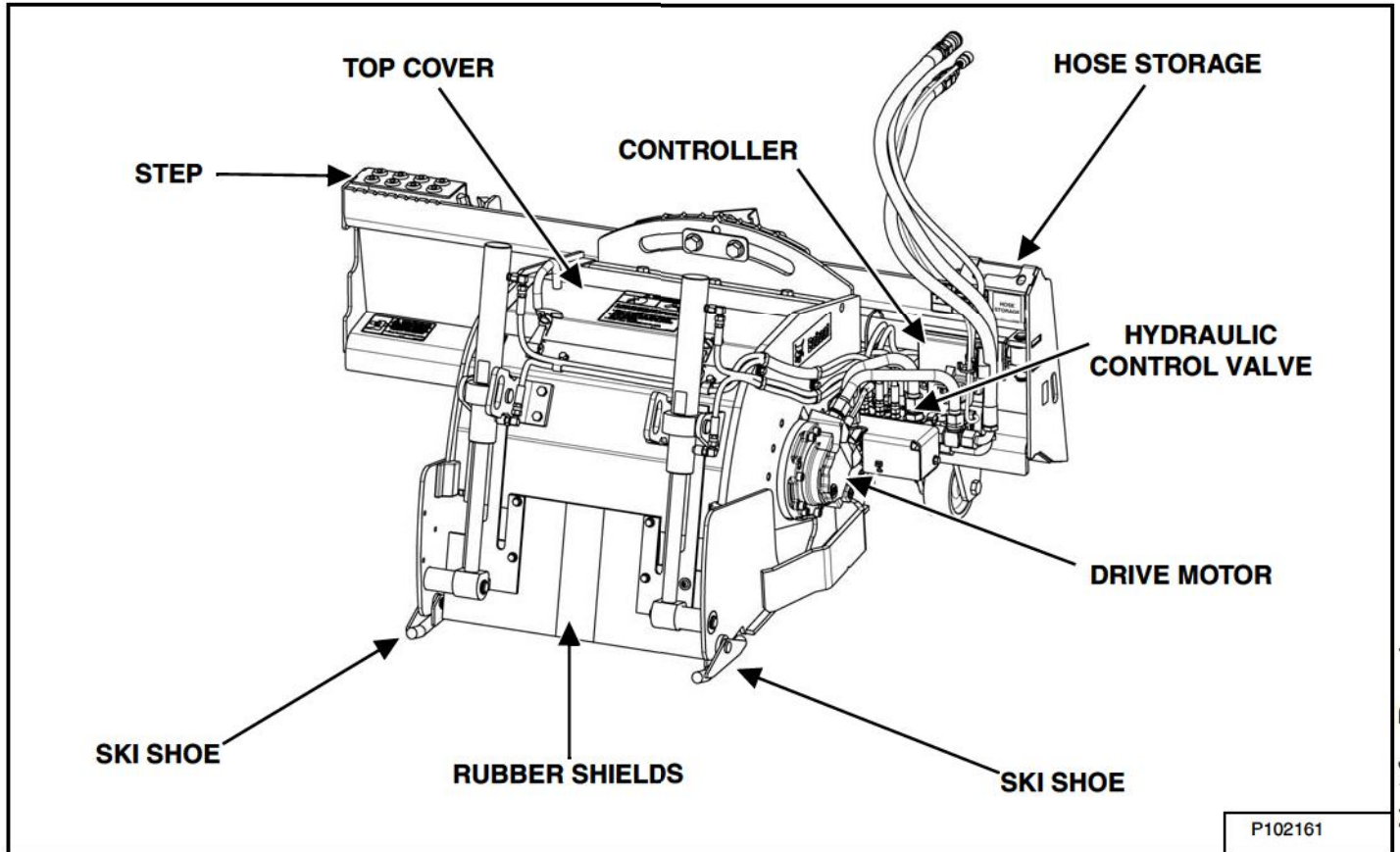

Dealer Copy -- Not for Resale

SAFETY AND MAINTENANCE

TROUBLESHOOTING	10-10-1
Chart	10-10-1
DAILY INSPECTION	10-20-1
Attachment Mounting Frame	10-20-1
Bob-Tach	10-20-1
Rubber Shield Inspection	10-20-2
DRUM	10-30-1
Checking The Carbide Tips	10-30-1
Removing Carbide Bits	10-30-1
Installing Carbide Bits	10-30-2
RUBBER SHIELDS	10-40-1
Removal	10-40-1
Installation	10-40-1
DRIVE CARRIER	10-50-1
Oil Change	10-50-1
LUBRICATING THE ATTACHMENT	10-60-1
Lubrication Locations (PNSFL)	10-60-1

Dealer Copy -- Not for Resale

TROUBLESHOOTING

Chart

 <b style="font-size: 24pt; margin-left: 10px;">WARNING	<p>Instructions are necessary before operating or servicing machine. Read and understand the Operation & Maintenance Manual, Operator's Handbook and signs (decals) on machine. Follow warnings and instructions in the manuals when making repairs, adjustments or servicing. Check for correct function after adjustments, repairs or service. Untrained operators and failure to follow instructions can cause injury or death.</p> <p style="text-align: right; font-size: 10pt;">W-2003-0807</p>
--	---

If the attachment is not working correctly, check the hydraulic system of the machine thoroughly before making any repairs on the attachment. Attachment problems can be affected by a hydraulic system that is not operating to specifications. Connect a flow meter to the machine to check the hydraulic pump output, relief valve setting and tube lines to check flow and pressure. (See the machine's Service Manual for the correct procedure to connect the flow meter.)

Use the following troubleshooting chart to locate and correct problems which most often occur with the attachment.

PROBLEM	CAUSE	CORRECTION
Planer cut is inadequate.	Carbide bits worn or missing.	Replace the carbide bits.
Noisy motor (with load).	Vibration; loose bolts.	Check torque.
External oil leaks.	Motor case pressure too high.	Check the case drain line.
	Defective assembly.	Check case drain line for blockage.
	Damaged O-rings.	Replace O-rings as needed.
Planer will not side shift.	Damage to wiring or electrical connectors.	See your Bobcat dealer.
	Not enough hydraulic pressure.	Test loader hydraulics for flow and pressure.
	Planer housing seized or rusted in place.	Remove rust or material interference.
Drum motor with load does not turn.	Hydraulic pressure is low.	Check relief valve setting.
	Internal hydraulic leaks.	Check motor.
Noisy motor (with no load).	Humming; worn bearings.	Replace bearings.
Loaded motor does not turn at normal speed.	Not enough hydraulic flow.	Check pump flow and rotation speed. Check Hi Flow diverter valve. Make sure Hi Flow is ON.
	Internal leaks.	Check cylinder block and valve block assembly.
		Check motor.
Drum motor does not rotate.	Front auxiliary hydraulics not engaged.	Engage the loader front auxiliary.
	Excessive hydraulic leakage.	Check hoses and tubelines.
	Hydraulic leaks.	Check cylinder and valve block assembly.
	No hydraulic flow.	Check pump drive and pump inlet.
	No hydraulic pressure.	Valves damaged or corroded.
Planer does not mill to correct depth.	Carbide bits worn depth.	Replace the carbide bits.
	Decals misplaced or missing.	Replace with new depth decals.
	Ski pivot bushings worn or missing.	Install new ski pivot bushings.
	Ski worn.	Replace ski.
Planer function(s) will not operate.	Valve contamination.	Check internal valve orifices.

Dealer Copy -- Not for Resale

Buy Now



Our support email:

ebooklibonline@outlook.com