



# Bobcat®

## Service Manual Tilt Bucket

(CLS1 80) S/N AJMB00101 & Above  
S/N ALNP00101 & Above  
(CLS1 100) S/N AJMC00101 & Above  
S/N AM6100101 & Above  
(CLS2 105) S/N AJME00101 & Above  
(CLS2 120) S/N AJMF00101 & Above  
(CLS2 140) S/N AJMG00101 & Above

(CLS3 105) S/N AJMH00101 & Above  
(CLS3 120) S/N AJMJ00101 & Above  
(CLS3 140) S/N AJMK00101 & Above  
(CLS4 120) S/N AJML00101 & Above  
(CLS4 140) S/N AJMM00101 & Above  
(CLS4 150) S/N AJMN00101 & Above  
S/N AY7P00101 & Above  
(CLS6 160) S/N AY7Z00101 & Above

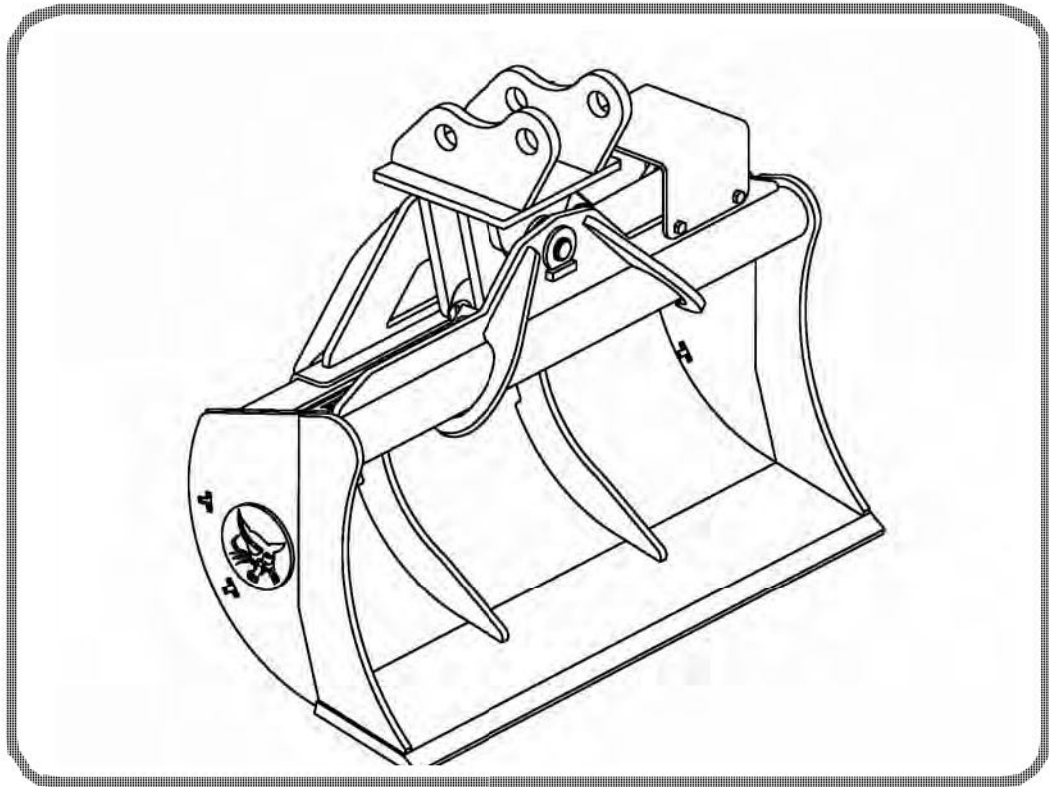

Dealer Copy -- Not for Resale



# MAINTENANCE SAFETY



## WARNING







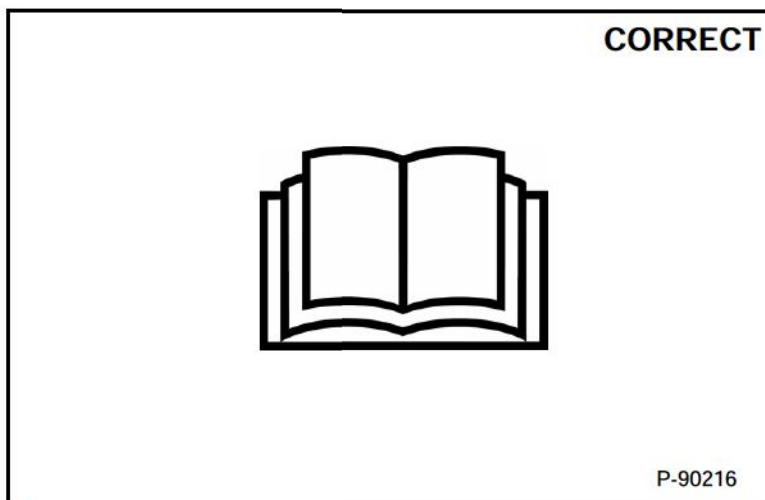

Instructions are necessary before operating or servicing machine. Read and understand the Operation & Maintenance Manual, Operator's Handbook and signs (decals) on machine. Follow warnings and instructions in the manuals when making repairs, adjustments or servicing. Check for correct function after adjustments, repairs or service. Untrained operators and failure to follow instructions can cause injury or death.

W-2003-0807



**Safety Alert Symbol:** This symbol with a warning statement, means: "Warning, be alert! Your safety is involved!" Carefully read the message that follows.



-  Never service attachments / implements without instructions. See Operation & Maintenance Manual and Attachment / Implement Service Manual.
-  Cleaning and maintenance are required daily.
-  Never service or adjust attachment / implement with the engine running unless instructed to do so in manual.
-  Always lower the attachment / implement to the ground before lubricating or servicing.
-  Avoid contact with leaking hydraulic fluid or diesel fuel under pressure. It can penetrate skin or eyes.
-  Stop, cool and clean engine of flammable materials before checking fluids.
-  Keep body, loose objects and clothing away from moving parts, electrical contacts, hot parts and exhaust.
-  Safety glasses are needed for eye protection from electrical arcs, battery acid, compressed springs, fluids under pressure and flying debris or when tools are used. Use eye protection approved for type of welding.

Dealer Copy -- Not for Resale

MSW30-0409

## CONTENTS

SAFETY & MAINTENANCE .....	10-01
HYDRAULIC SYSTEM .....	20-01
MAINFRAME .....	30-01
SPECIFICATIONS .....	SPEC-01
ALPHABETICAL INDEX .....	INDEX-01

Dealer Copy -- Not for Resale

## FOREWORD

SERIAL NUMBER LOCATION .....	1-7
Attachment Serial Number .....	1-7
DELIVERY REPORT .....	1-7
ATTACHMENT IDENTIFICATION .....	1-8

## SERIAL NUMBER LOCATION

### Attachment Serial Number

Always use the serial number of the tilt bucket when requesting service information or when ordering parts. Early or later models (identification made by serial number) may use different parts, or it may be necessary to use a different procedure in doing a specific service operation.

Figure 1

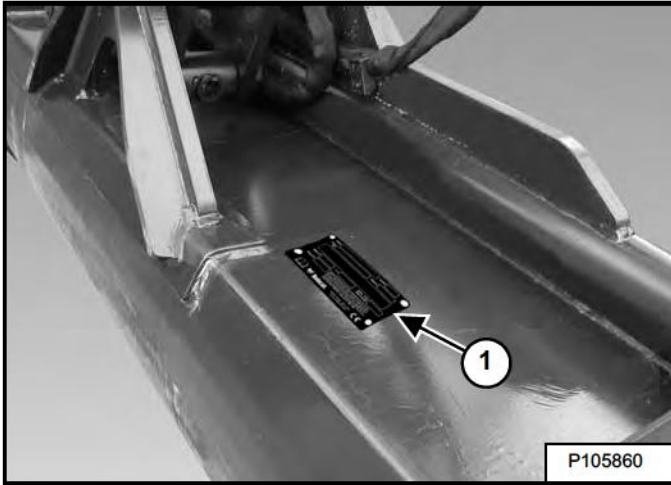

The tilt bucket serial number plate (Item 1) [Figure 1] is located on the bucket.

## DELIVERY REPORT

Figure 2

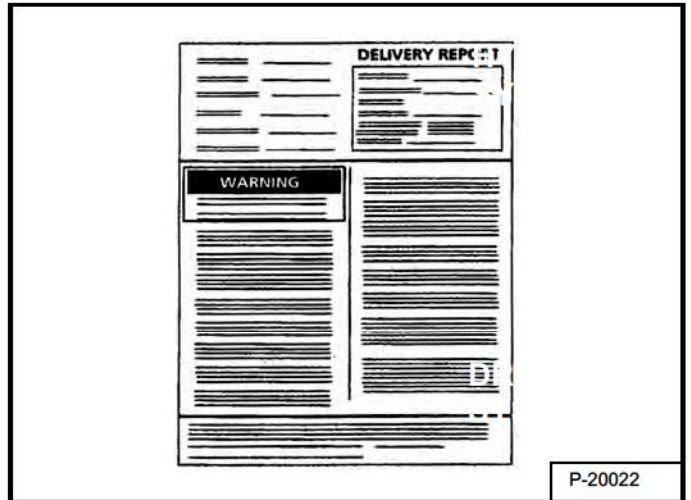

The delivery report must be completed by the dealer and signed by the owner or operator when the tilt bucket is delivered. An explanation of the form must be given to the owner. Make sure it is completed in full [Figure 2].

## ATTACHMENT IDENTIFICATION

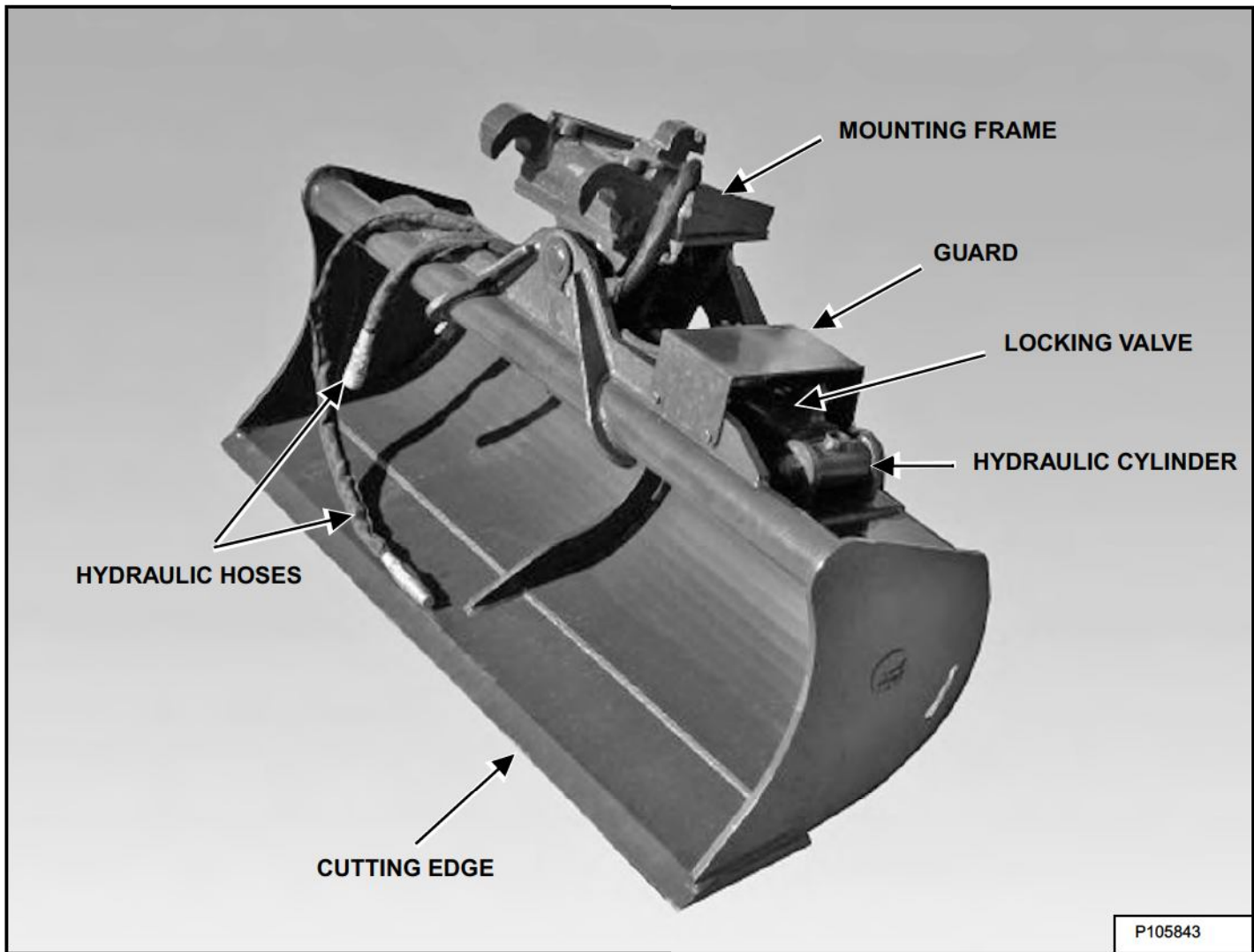

Dealer Copy -- Not for Resale

## SAFETY & MAINTENANCE

TROUBLESHOOTING .....	10-10-1
Chart .....	10-10-1
SERVICE SCHEDULE .....	10-20-1
Description .....	10-20-1
INSPECTION .....	10-30-1
Tilt Bucket .....	10-30-1
Pin-On Attachment .....	10-30-1
Quick Coupler (Klac™ System) .....	10-30-2
Quick Coupler (Lehnhoff® System) .....	10-30-2
REGULAR MAINTENANCE ITEMS .....	10-40-1
Cleaning The Tilt Bucket .....	10-40-1
LUBRICATING THE ATTACHMENT .....	10-50-1
Lubrication Locations .....	10-50-1
ATTACHMENT STORAGE AND RETURN TO SERVICE .....	10-60-1
Storage .....	10-60-1
Return To Service .....	10-60-1

## TROUBLESHOOTING

### Chart

 <b style="font-size: 24pt; margin-left: 10px;">WARNING</b>	<p>Instructions are necessary before operating or servicing machine. Read and understand the Operation &amp; Maintenance Manual, Operator's Handbook and signs (decals) on machine. Follow warnings and instructions in the manuals when making repairs, adjustments or servicing. Check for correct function after adjustments, repairs or service. Untrained operators and failure to follow instructions can cause injury or death.</p> <p style="text-align: right; font-size: 10pt;">W-2003-0807</p>
--	---

If the tilt bucket is not working correctly, check the hydraulic system of the machine thoroughly before making any repairs on the tilt bucket. Tilt Bucket problems can be affected by a hydraulic system that is not operating to specifications or such problems as a plugged fuel filter or hydraulic filter in the machine. (See the machine's Service Manual for the correct troubleshooting procedures.)

TROUBLESHOOTING THE TILT BUCKET		
PROBLEM	CAUSE	CORRECTION
Tilt bucket does not swing.	No hydraulic flow.	Check quick couplers for connection.
		Check damaged hose ends and fittings.
Tilt bucket only swings in one direction.	Tilt bucket is connected to an auxiliary hydraulic circuit that is not 2-way.	Ensure that the tilt bucket is connected to a 2-way, hydraulic circuit. A proportional auxiliary hydraulic circuit is recommended, if available. (See the machine's Operation & Maintenance Manual.)
Tilt bucket is difficult to control.	Tilt bucket is connected to an auxiliary hydraulic circuit that is not proportional.	
Tilt bucket swings the opposite direction than expected.	Hoses are reversed.	Swap the male and female couplers and reroute hoses as necessary.
Hydraulic fluid is leaking.	Hoses or fittings are loose or damaged.	Tighten or replace loose or damaged fittings and hoses as necessary.
Noise from the hydraulic cylinder when tilting the bucket.	Bucket block valve not adjusted.	Adjust the bucket block valve. (See the Tilt Bucket Service Manual for more detailed information.)

Dealer Copy -- Not for Resale



## SERVICE SCHEDULE

### Description

 <b>WARNING</b>	Instructions are necessary before operating or servicing machine. Read and understand the Operation & Maintenance Manual, Operator's Handbook and signs (decals) on machine. Follow warnings and instructions in the manuals when making repairs, adjustments or servicing. Check for correct function after adjustments, repairs or service. Untrained operators and failure to follow instructions can cause injury or death. <span style="float: right;">W-2003-0807</span>
--	---

Maintenance work must be done at regular intervals. Failure to do so will result in excessive wear and early failures. The service schedule is a guide for correct maintenance of the Bobcat product.

SERVICE SCHEDULE		FREQUENCY
ITEM	SERVICE REQUIRED	10 HOURS
Pivot Points	Lubricate all tilt bucket grease fittings.	

Dealer Copy -- Not for Resale

**Buy Now**



Our support email:

[ebooklibonline@outlook.com](mailto:ebooklibonline@outlook.com)