

Service Manual

**GP15K, GP18K, GP20K, GP25K, GP30K, GP35K
DP15K, DP18K, DP20K, DP25K, DP30K, DP35K
Chassis, Mast & Options**

GP15K	ET31A-50001-up	DP15K	ET16B-55001-up	MC
GP18K	ET31A-75001-up	DP18K	ET16B-75001-up	
GP20K	ET17B-05001-up	DP20K	ET18B-05001-up	
GP25K	ET17B-55001-up	DP25K	ET18B-55001-up	
GP30K	ET13D-35001-up	DP30K	ET14C-35001-up	
GP35K	ET13D-55001-up	DP35K	ET14C-55001-up	

FOREWORD

This service manual is a guide to servicing of Caterpillar® Lift Trucks for 1.5 thru 3.5 ton models. The instructions are grouped by systems to serve the convenience of your ready reference.

Long productive life of your lift trucks depends to a great extent on correct servicing — the servicing consistent with what you will learn from this service manual. We hope you read the respective sections of this manual carefully and know all the components you will work on before attempting to start a test, repair or rebuild job.

The descriptions, illustrations and specifications contained in this manual were of the trucks of serial numbers in effect at the time it was approved for printing. Caterpillar reserves the right to change specifications or design without notice and without incurring obligation.

For the items pertaining to the engines, refer to the following service manuals:

- 4G63/4G64 Gasoline Engine Service Manual (Pub. No. 99729-84120)
- S4Q2 Diesel Engine Service Manual (Pub. No. 99719-73100)
- 4DQ7/S4S Diesel Engine Service Manual (Pub. No. 99719-51110)

SAFETY RELATED SIGNS

The following safety related signs are used in this service manual to emphasize important and critical instructions:



Indicates a specific potential hazard resulting in serious bodily injury or death.



Indicates a specific potential hazard resulting in bodily injury, or damage to, or destruction of, the machine.



Indicates a condition that can cause damage to, or shorten service life of, the machine.

HOW TO READ THIS MANUAL

Disassembly Diagram (example)

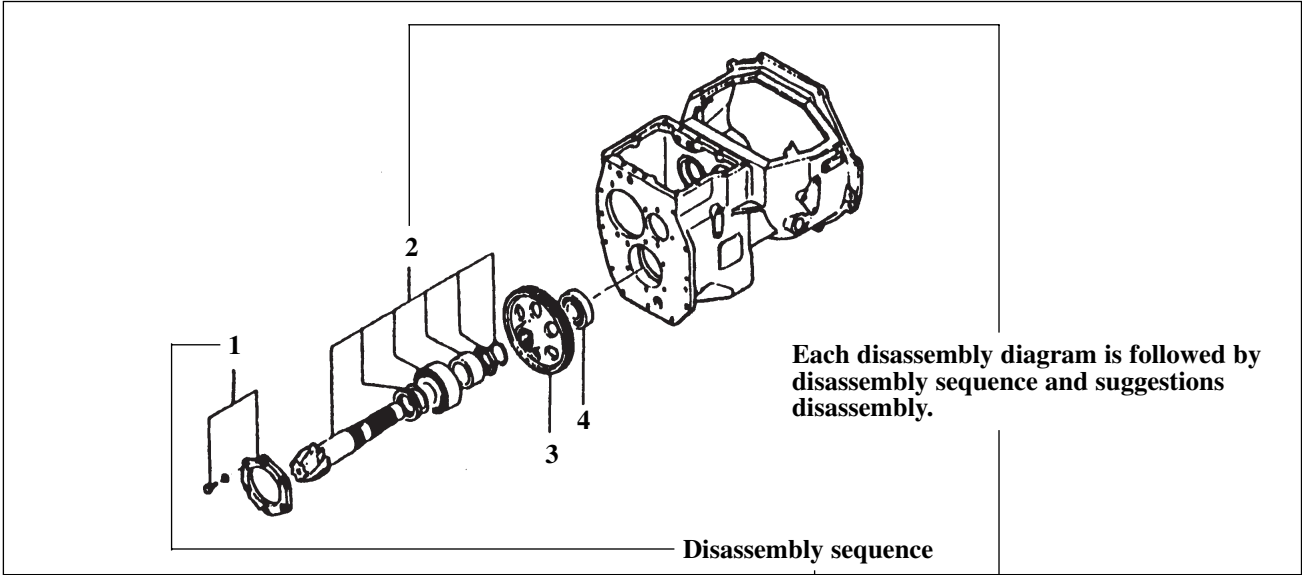

- 1 Cover [bolt, washer] (part name)
- 2 Output shaft (part name)

Suggestion for disassembly

(1) Output shaft removal

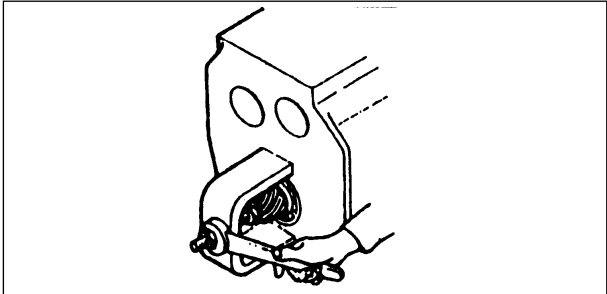

Unit: mm (in.)

Clearance between cylinder and piston	A	0.020 to 0.105 (0.00079 to 0.00413)
	B	0.15 (0.0059)

A: Assembly standard
B: Repair or service limit

SAFETY

 **WARNING**

The proper and safe lubrication and maintenance for this lift truck, recommended by Caterpillar, are outlined in the OPERATION & MAINTENANCE MANUAL for these trucks.

Improper performance of lubrication or maintenance procedures is dangerous and could result in injury or death. Read and understand the OPERATION & MAINTENANCE MANUAL before performing any lubrication or maintenance.

The serviceman or mechanic may be unfamiliar with many of the systems on this truck. This makes it important to use caution when performing service work. A knowledge of the system and/or components is important before the removal or disassembly of any component.

Because of the size of some of the truck components, the serviceman or mechanic should check the weights noted in this Manual. Use proper lifting procedures when removing any components.

Following is a list of basic precautions that should always be observed.

1. Read and understand all warning plates and decals on the truck before operating, lubricating or repairing the product.
2. Always wear protective glasses and protective shoes when working around trucks. In particular, wear protective glasses when pounding on any part of the truck or its attachments with a hammer or sledge. Use welder's gloves, hood/goggles, apron and other protective clothing appropriate to the welding job being performed. Do not wear loose-fitting or torn clothing. Remove all rings from fingers when working on machinery.
3. Do not work on any truck that is supported only by lift jacks or a hoist. Always use blocks or jack stands to support the truck before performing any disassembly.

 **WARNING**

Do not operate this truck unless you have read and understand the instructions in the OPERATION & MAINTENANCE MANUAL. Improper truck operation is dangerous and could result in injury or death.

4. Lower the forks or other implements to the ground before performing any work on the truck. If this cannot be done, make sure the forks or other implements are blocked correctly to prevent them from dropping unexpectedly.
5. Use steps and grab handles (if applicable) when mounting or dismounting a truck. Clean any mud or debris from steps, walkways or work platforms before using. Always face truck when using steps, ladders and walkways. When it is not possible to use the designed access system, provide ladders, scaffolds, or work platforms to perform safe repair operations.
6. To avoid back injury, use a hoist when lifting components which weigh 23 kg (50 lb.) or more. Make sure all chains, hooks, slings, etc., are in good condition and are of the correct capacity. Be sure hooks are positioned correctly. Lifting eyes are not to be side loaded during a lifting operation.
7. To avoid burns, be alert for hot parts on trucks which have just been stopped and hot fluids in lines, tubes and compartments.
8. Be careful when removing cover plates. Gradually back off the last two bolts or nuts located at opposite ends of the cover or device and pry cover loose to relieve any spring or other pressure, before removing the last two bolts or nuts completely.
9. Be careful when removing filler caps, breathers and plugs on the truck. Hold a rag over the cap or plug to prevent being sprayed or splashed by liquids under pressure. The danger is even greater if the truck has just been stopped because fluids can be hot.

10. Always use tools that are in good condition and be sure you understand how to use them before performing any service work.
11. Reinstall all fasteners with same part number. Do not use a lesser quality fastener if replacements are necessary. Do not mix metric fasteners with standard nuts and bolts.
12. If possible, make all repairs with the truck parked on a level, hard surface. Block truck so it does not roll while working on or under truck.
13. Disconnect battery and discharge any capacitors (electric trucks) before starting to work on truck. Hang "Do not Operate" tag in the Operator's Compartment.
14. Repairs, which require welding, should be performed only with the benefit of the appropriate reference information and by personnel adequately trained and knowledgeable in welding procedures. Determine type of metal being welded and select correct welding procedure and electrodes, rods or wire to provide a weld metal strength equivalent at least to that of parent metal.
15. Do not damage wiring during removal operations. Reinstall the wiring so it is not damaged nor will it be damaged in operation by contacting sharp corners, or by rubbing against some object or hot surface. Do not connect wiring to a line containing fluid.
16. Be sure all protective devices including guards and shields are properly installed and functioning correctly before starting a repair. If a guard or shield must be removed to perform the repair work, use extra caution.
17. Always support the mast and carriage to keep carriage or attachments raised when maintenance or repair work is performed, which requires the mast in the raised position.
18. Loose or damaged fuel, lubricant and hydraulic lines, tubes and hoses can cause fires. Do not bend or strike high pressure lines or install ones which have been bent or damaged. Inspect lines, tubes and hoses carefully. Do not check for leaks with your hands. Pin hole (very small) leaks can result in a high velocity oil stream that will be invisible close to the hose. This oil can penetrate the skin and cause personal injury. Use cardboard or paper to locate pin hole leaks.
19. Tighten connections to the correct torque. Make sure that all heat shields, clamps and guards are installed correctly to avoid excessive heat, vibration or rubbing against other parts during operation. Shields that protect against oil spray onto hot exhaust components in event of a line, tube or seal failure, must be installed correctly.
20. Relieve all pressure in air, oil or water systems before any lines, fittings or related items are disconnected or removed. Always make sure all raised components are blocked correctly and be alert for possible pressure when disconnecting any device from a system that utilizes pressure.
21. Do not operate a truck if any rotating part is damaged or contacts any other part during operation. Any high speed rotating component that has been damaged or altered should be checked for balance before reusing.

Vehicle Exterior

- This Service Manual deals with all components or systems of the Caterpillar Lift Trucks; except for the engine and attachment, which are covered in the respective manuals.

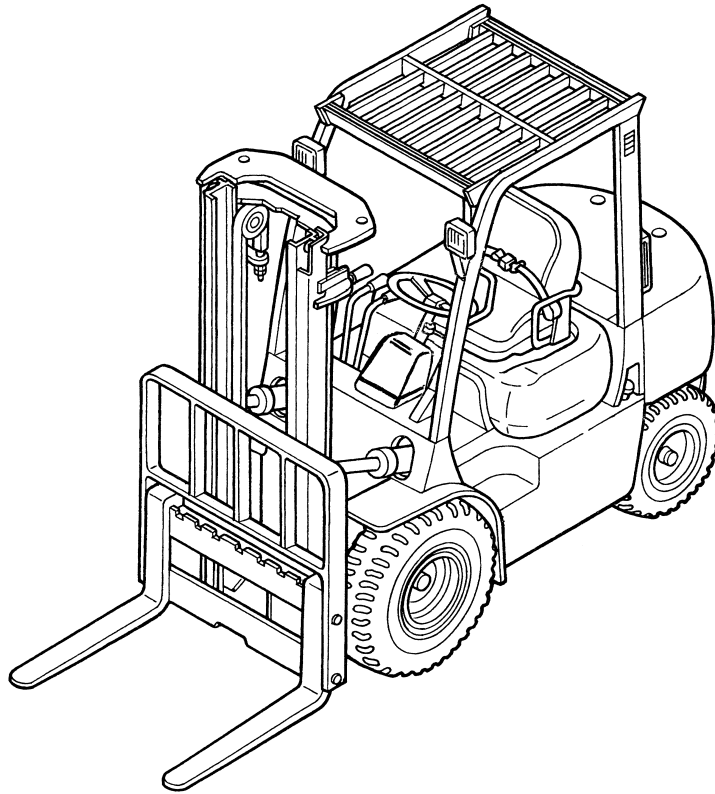

207151

Models

- This Service Manual furnishes servicing and maintenance information for the following trucks:

Truck Model	Serial Number	Engine Mounted
GP15K	ET31A-50001-up	Mitsubishi 4G63 Gasoline Engine
DP15K	ET16B-55001-up	Mitsubishi S4Q2 Diesel Engine
GP18K	ET31A-75001-up	Mitsubishi 4G63 Gasoline Engine
DP18K	ET16B-75001-up	Mitsubishi S4Q2 Diesel Engine
GP20K	ET17B-05001-up	Mitsubishi 4G63 Gasoline Engine
DP20K	ET18B-05001-up	Mitsubishi S4S Diesel Engine
GP25K	ET17B-55001-up	Mitsubishi 4G63 Gasoline Engine
DP25K	ET18B-55001-up	Mitsubishi S4S Diesel Engine
GP30K	ET13D-35001-up	Mitsubishi 4G64 Gasoline Engine
DP30K	ET14C-35001-up	Mitsubishi S4S Diesel Engine
GP35K	ET13D-55001-up	Mitsubishi 4G64 Gasoline Engine
DP35K	ET14C-55001-up	Mitsubishi S4S Diesel Engine

Serial Number Locations

Nameplate

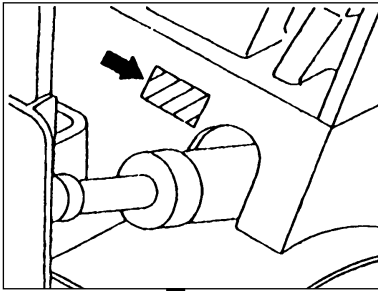

Chassis Serial Number

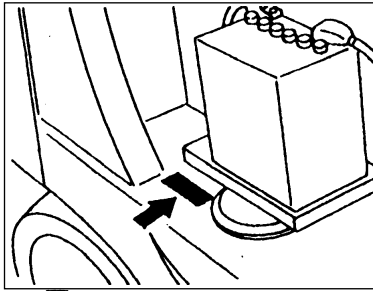

Engine Serial Number
(gasoline models)

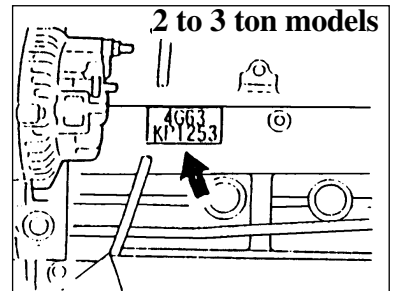
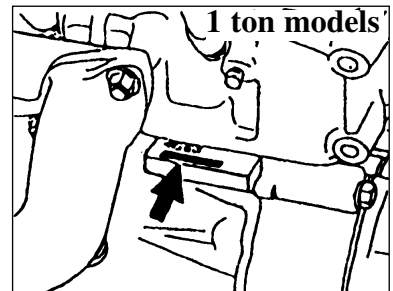

Engine Serial Number
(diesel models)

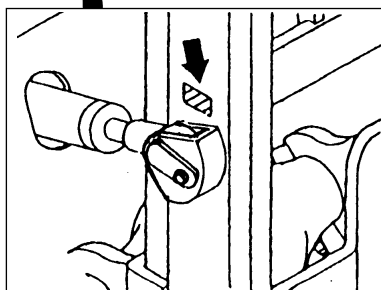
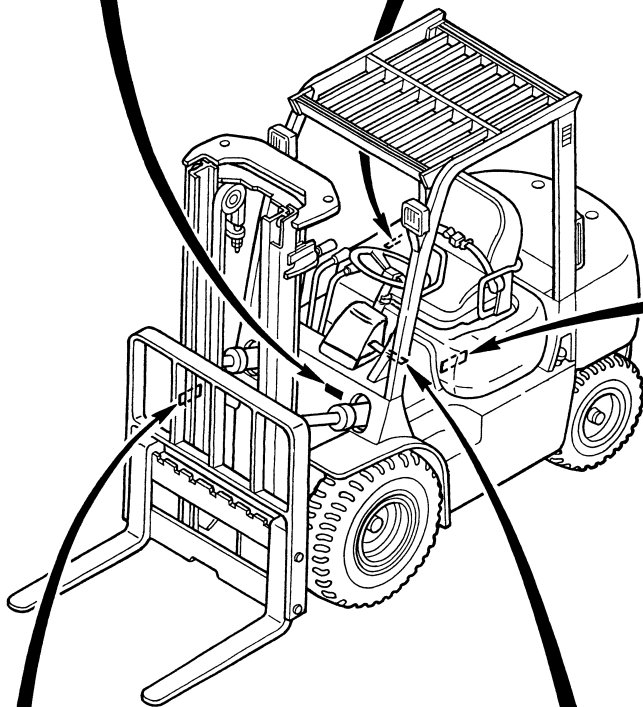
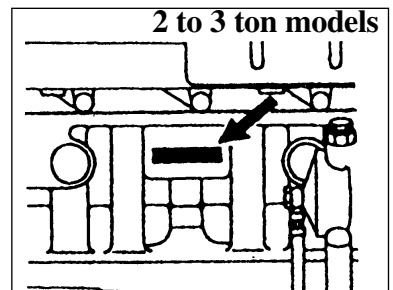
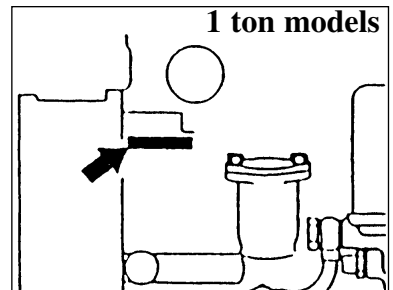

Mast Serial Number

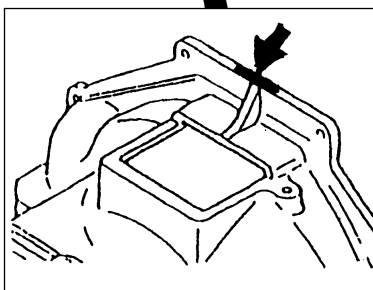

Transmission Serial Number

Chassis and Mast Model Identification

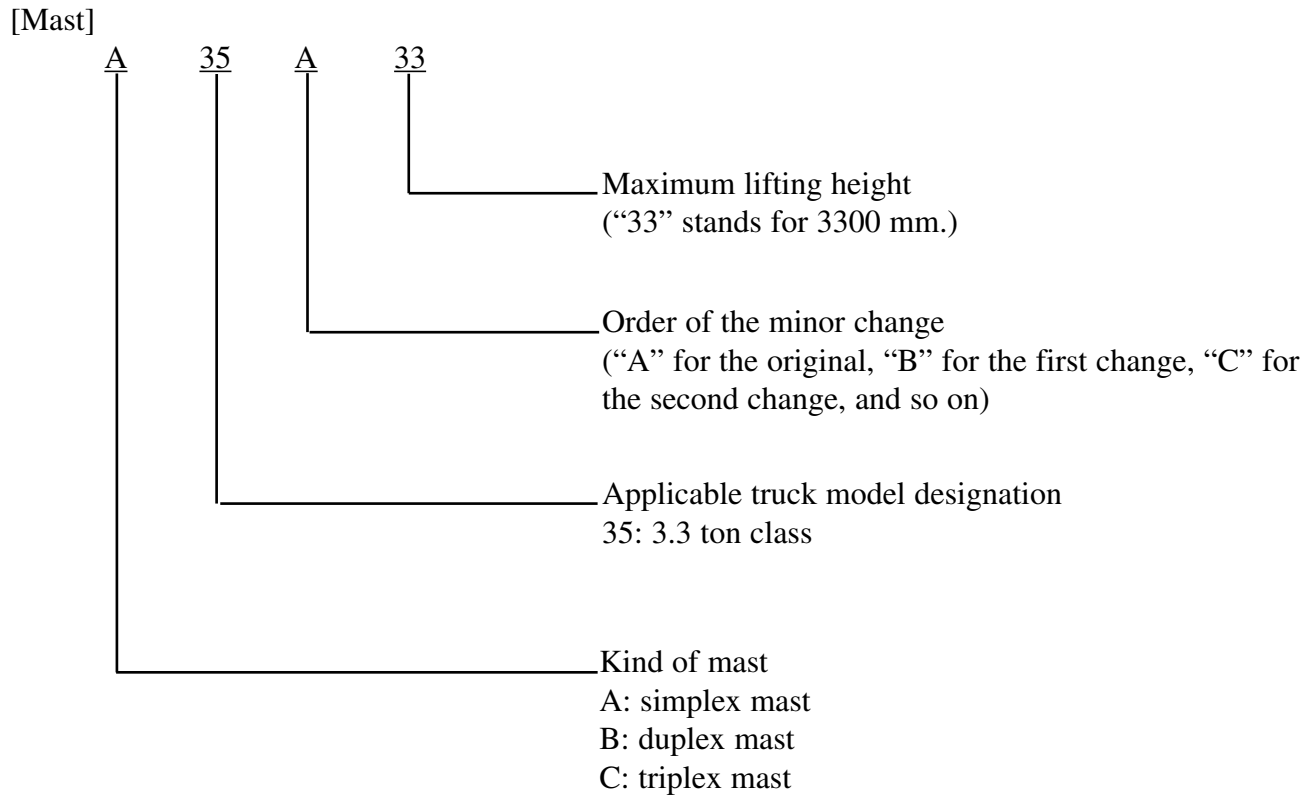
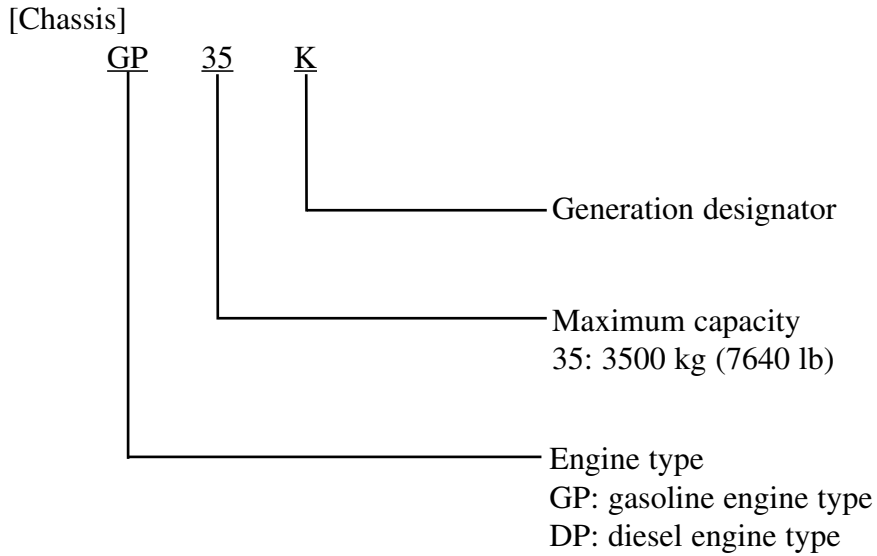

GENERAL INFORMATION

Dimensions

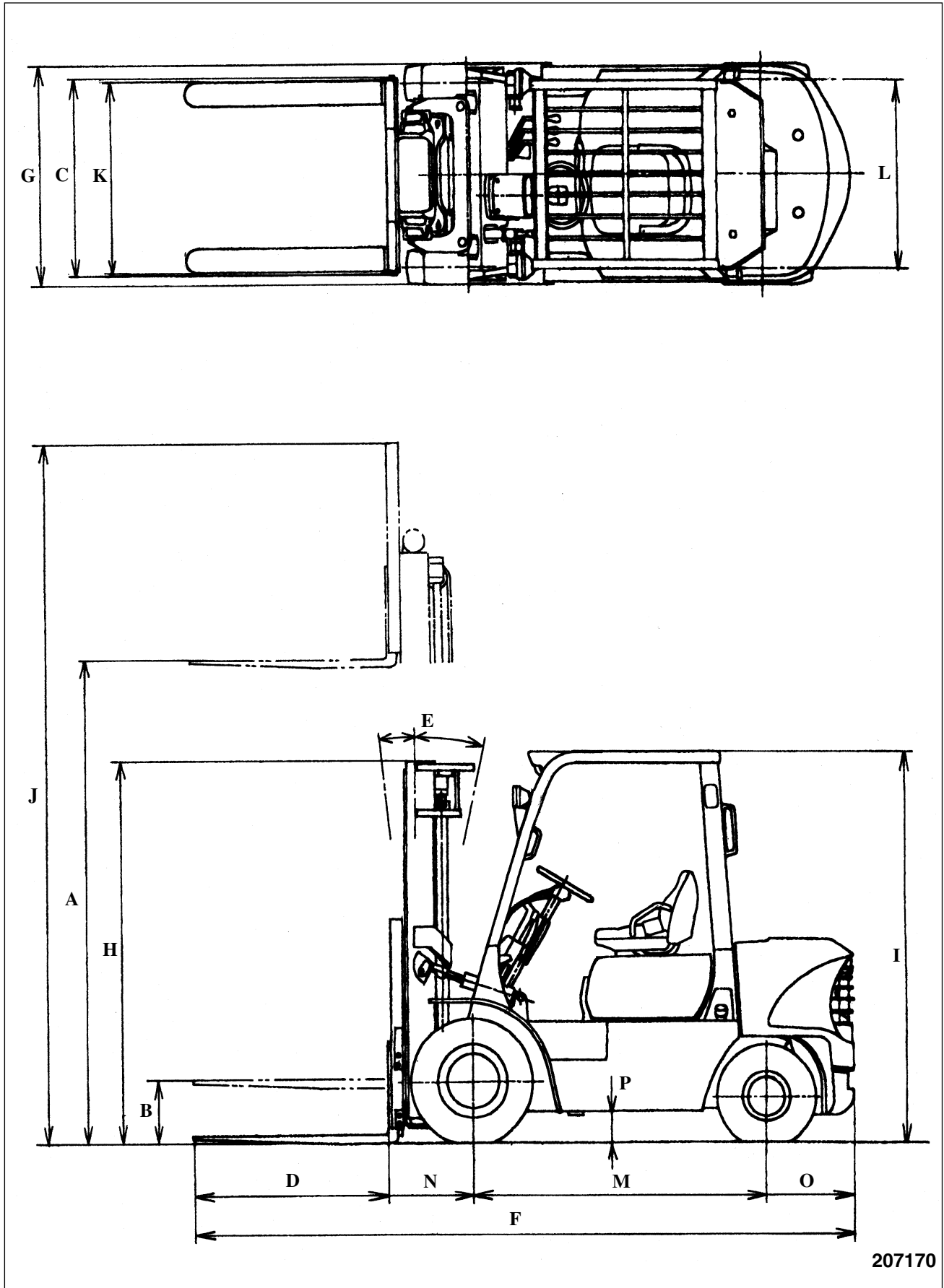

207170

GENERAL INFORMATION

Unit: mm (in.)

Ref. No.	Truck Models		GP15K	GP18K	GP20K	GP25K	GP30K	GP35K
			DP15K	DP18K	DP20K	DP25K	DP30K	DP35K
A	Maximum lift		3300 (130)		3300 (130)		3300 (130)	
B	Free lift (floor to fork top)	Simplex mast	110 (4.3)		140 (5.5)		150 (5.9)	
		Duplex mast	1120 (44.1)	1125 (44.3)	1125 (44.3)	1130 (44.5)	1160 (45.7)	1295 (51)
		Triplex mast						
C	Fork spread		220 to 920 (8.7 to 36.2)		250 to 1000 (9.8 to 39.4)		250 to 1000 (9.8 to 39.4)	
D	Fork length		1070 (42)		1070 (42)		1070 (42)	
E	Tilt angle (forward – backward)		6° – 10°		6° – 10°		6° – 10°	
F	Overall length		3280/3315 (129.1/130.5)		3515/3585 (138.4/141.1)		3775/3830 (143/150.8)	
G	Overall width (w/single tires)		1065 (41.9)		1150 (45.3)		1275/1290 (50.2/50.8)	
	Overall width (w/double tires) (outside)		1330 (52.4)		1480 (58.3)		1490 (58.7)	
H	Overall height (to top of mast lowered)		2145 (84.4)		2210 (87)		2210/2320 (87/91.3)	
I	Overall height (to top of overhead guard)		2055 (80.9)		2070 (81.5)		2095/2105 (82.5/82.9)	
J	Overall height (mast extended)	Simplex mast	4030 (158.7)		4030 (158.7)		4135 (180.1)	
		Duplex mast	4350 (171.3)		4355 (171.5)		4305 (169.5)	4355 (171.5)
		Triplex mast	5805 (228.5)		5805 (228.5)		5755 (226.6)	
K	Tread (front-single tires)		890 (35.0)		960 (37.8)		1060 (41.7)	
	Tread (front-double tires)		1025 (40.4)		1140 (44.9)		1140 (44.9)	
L	Tread (rear)		450 (17.7)		980 (38.6)		980 (38.6)	
M	Wheelbase		1390 (54.7)		1600 (63.0)		1750 (68.9)	
N	Front overhang		402 (15.8)		457 (18)		490 (19.3)	
O	Rear overhang		418/453 (16.5/17.8)		388/458 (15.3/18)		465/520 (18.3/20.5)	
P	Underclearance (at frame)		150 (5.9)		160 (6.3)		190 (7.5)	200 (7.9)

GENERAL INFORMATION

Technical Data (Standard Models)

Truck Model			GP15K	DP15K	GP18K	DP18K	GP20K	DP20K		
Designation			ET31A	ET16B	ET31A	ET16B	ET17B	ET18B		
Work performance	Capacity/load center		kg/mm (lb/in.)	1500/500 (3000/24)		1750/500 (3500/24)		2000/500 (4000/24)		
	Maximum lift height		mm (in.)	3300 (130)		3300 (130)		3300 (130)		
	Lift speed (rated load)		mm/sec	490 (96)	600 (118)	490 (96)	600 (118)	510 (100)	640 (126)	
	Lowering speed (rated load)		(fpm)	500 (98)		500 (98)		500 (98)		
	Mast tilt (forward – backward)		degree	6 – 10		6 – 10		6 – 10		
	Free lift	Simplex mast		mm (in.)	110 (4.3)		110 (4.3)		140 (5.5)	
Duplex mast		1120 (44.1)			1125 (44.3)		1125 (44.3)			
Triplex mast		1120 (44.1)			1125 (44.3)		1125 (44.3)			
Traveling performance	Travel speed	Powershift transmission models	Forward	km/h (mph)	0 to 19 (0 to 11.8)		0 to 18 (0 to 11.2)			
			Reverse		0 to 19 (0 to 11.8)		0 to 18 (0 to 11.2)	0 to 19 (0 to 11.8)		
	Minimum turning radius		mm (in.)	1990 (78.3)		2020 (79.5)		2185 (86)		
	Minimum intersecting isle	Single wheels		1780 (70.1)		1800 (70.9)		1900 (74.8)		
		Double wheels	1880 (74.0)		1900 (74.8)		2020 (79.5)			
	Gradeability (reted load)	Powershift transmission models		% (tan)	30	28	28	25	28	35
Dimensions	Overall length		mm (in.)	3280 (129.1)		3315 (130.5)		3515 (138.4)		
	Overall width	Single wheels		1065 (41.9)		1065 (41.9)		1150 (45.3)		
		Double wheels		1330 (52.4)		1330 (52.4)		1480 (58.3)		
	Overall height	To top of mast lowered		2145 (84.4)		2145 (84.4)		2210 (87)		
		To top of mast extended		4030 (158.7)		4030 (158.7)		4030 (158.7)		
		To top of overhead guard		2055 (80.9)		2055 (80.9)		2070 (81.5)		
	Wheel base			1390 (54.7)		1390 (54.7)		1600 (63.0)		
	Tread	Front		Single wheels	890 (35.0)		890 (35.0)		960 (37.8)	
				Double wheels	1025 (40.4)		1025 (40.4)		1140 (44.9)	
	Overhang	Rear		900 (35.4)		900 (35.4)		980 (38.6)		
		Front		402 (15.8)		402 (15.8)		457 (18)		
	Underclearance (at frame)	Rear		418 (16.5)		453 (17.8)		388 (15.3)		
		Front		150 (5.9)		150 (5.9)		160 (6.3)		
	Tire size and pressure	Front		Single wheels	6.50 – 10 – 10 686 (7) [100]		6.50 – 10 – 10 686 (7) [100]		7.00 – 12 – 12 686 (7) [100]	
Double wheels			4.50 – 12 – 8 686 (7) [100]		4.50 – 12 – 8 686 (7) [100]		5.00 – 15 – 8 686 (7) [100]			
Rear		5.00 – 8 – 8 686 (7) [100]		5.00 – 8 – 8 686 (7) [100]		6.00 – 9 – 10 686 (7) [100]				
Weight	Single wheels (without load)	Service weight		2470 (5450)	2550 (5620)	2640 (5820)	2720 (6000)	3260 (7190)	3380 (7450)	
		Load distribution	Front axle	1040 (2290)	1070 (2360)	1000 (2210)	1030 (2270)	1460 (3220)	1500 (3310)	
			Rear axle	1430 (3150)	1480 (3260)	1640 (3620)	1690 (3730)	1770 (3900)	1850 (4080)	

GENERAL INFORMATION

GP25K	DP25K	GP30K	DP30K	GP35K	DP35K
ET17B	ET18B	ET13D	ET14C	ET13D	ET14C
2500/500 (5000/24)		3000/500 (6000/24)		3500/500 (7000/24)	
3300 (130)		3300 (130)		3300 (130)	
550 (108)	660 (130)	470 (93)	510 (100)	400 (79)	430 (85)
500 (98)		530 (104)		440 (87)	
6 – 10		6 – 10		6 – 10	
140 (5.5)		150 (5.9)		150 (5.9)	
1130 (44.5)		1160 (45.7)		1295 (51)	
1130 (44.5)		1160 (45.7)		1295 (51)	
0 to 18 (0 to 11.2)		0 to 19 (0 to 11.8)		0 to 19 (0 to 11.8)	0 to 18 (0 to 11.2)
0 to 18 (0 to 11.2)	0 to 19 (0 to 11.8)	0 to 19 (0 to 11.8) (0 to 11.8)		0 to 19 (0 to 11.8)	0 to 19 (0 to 11.8)
2245 (88.4)		2445 (96.2)		2485 (97.8)	
1970 (77.6)		2090 (82.3)		2120 (83.5)	
2090 (82.3)		2170 (85.4)		2190 (86.2)	
23	29	23	24	19	20
3585 (141.1)		3775 (143)		3830 (150.8)	
1150 (45.3)		1275 (50.2)		1290 (50.8)	
1480 (58.3)		1490 (58.7)		1490 (58.7)	
2210 (87)		2210 (87)		2320 (91.3)	
4030 (158.7)		4135 (162.8)		4135 (162.8)	
2070 (81.5)		2095 (82.5)		2105 (82.9)	
1600 (63.0)		1750 (68.9)		1750 (68.9)	
960 (37.8)		1060 (41.7)		1060 (41.7)	
1140 (44.9)		1140 (44.9)		1140 (44.9)	
980 (38.6)		980 (38.6)		980 (38.6)	
457 (18)		490 (19.3)		490 (19.3)	
458 (18)		465 (18.3)		520 (20.5)	
160 (6.3)		190 (7.5)		200 (7.9)	
7.00 – 12 – 12 686 (7) [100]		28 × 9 – 15 – 12 686 (7) [100]		250 – 15 – 16 834 (8.5) [120]	
5.00 – 15 – 8 686 (7) [100]		6.50 – 10 – 10 686 (7) [100]		6.50 – 10 – 10 686 (7) [100]	
6.00 – 9 – 10 686 (7) [100]		6.50 – 10 – 10 686 (7) [100]		6.50 – 10 – 12 883 (9.0) [128]	
3620 (7990)	3740 (8250)	4220 (9310)	4340 (9570)	4600 (10140)	4720 (10410)
1400 (3090)	1440 (3180)	1760 (3880)	1710 (3770)	1790 (3950)	1830 (4040)
2220 (4900)	2300 (5070)	2460 (5420)	2530 (5580)	2810 (6200)	2890 (6370)

GENERAL INFORMATION

Truck Model				GP15K	DP15K	GP18K	DP18K	GP20K	DP20K
Weight	Double wheels (withoout load)	Service weight		2500 (5510)	2580 (5690)	2670 (5890)	2750 (6060)	3330 (7340)	3450 (7610)
		Load distribution	Front axle	1070 (2360)	1100 (2430)	1030 (2270)	1060 (2340)	1530 (3370)	1570 (3460)
			Rear axle	1430 (3150)	1480 (3260)	1640 (3620)	1690 (3730)	1770 (3900)	1850 (4080)
Engine	Engine model			4G63	S4Q2	4G63	S4Q2	4G63	S4S
	Manufacturer			Mitsubishi Motors	MHI	Mitsubishi Motors	MHI	Mitsubishi Motors	MHI
	Type			Gasoline	Diesel	Gasoline	Diesel	Gasoline	Diesel
	Cooling System			Water		Water		Water	
	No. of cylinders - arrangement			4 -in-line		4 -in-line		4 -in-line	
	No. of strokes			4		4		4	
	Types of combustion chambers			Semi-spherical	Swirl	Semi-spherical	Swirl	Semi-spherical	Swirl
	Valve arrangement			OHC	OHV	OHC	OHV	OHC	OHV
	Type of cylinder liners			Integral with cylinder block	Dry	Integral with cylinder block	Dry	Integral with cylinder block	Dry
	Cylinder bore × stroke		mm (in.)	85 × 88 (3.346 × 3.465)	88 × 103 (3.465 × 4.055)	85 × 88 (3.346 × 3.465)	88 × 103 (3.465 × 4.055)	85 × 88 (3.346 × 3.465)	94 × 120 (3.701 × 4.724)
	Displacement		cc (cu. in.)	1997 (121.8)	2505 (152.8)	1997 (121.8)	2505 (152.8)	1997 (121.8)	3331 (203.2)
	Compression ratio			8.5 : 1	22 : 1	8.5 : 1	22 : 1	8.5 : 1	22 : 1
	Rated output		PS/rpm	42/2400	40/2200	42/2400	40/2200	42/2400	60/2200
	Maximum torque		N·m (kgf·m) [lbf·ft]/rpm	134 (13.7) [99]/1600	136 (13.9) [101]/1600	134 (13.7) [99]/1600	136 (13.9) [101]/1600	134 (13.7) [99]/1600	201 (20.5) [148]/1400
	Dimensions (length × width × height)		mm (in.)	653 × 604 × 759 (25.7 × 23.8 × 29.9)	686 × 493 × 623 (27.0 × 19.4 × 24.5)	653 × 604 × 759 (25.7 × 23.8 × 29.9)	686 × 493 × 623 (27.0 × 19.4 × 24.5)	653 × 604 × 759 (25.7 × 23.8 × 29.9)	647 × 552 × 712 (25.5 × 21.7 × 28)
	Weight (service)		kg (lb)	150 (330)	180 (397)	150 (330)	180 (397)	150 (330)	260 (570)
	Location			Rear		Rear		Rear	
	Intake valves	Open BTDC	degree	12	30	12	30	12	30
		Close ABDC		40	50	40	50	40	50
	Exhaust valves	Open BBDC		54	74	54	74	54	74
		Close ATDC		6	30	6	30	6	30
	Valve clearance	Intake valves	mm (in.)	0.00 (hot)	0.25 (0.0098) (cold)	0.00 (hot)	0.25 (0.0098) (cold)	0.00 (hot)	0.25 (0.0098) (cold)
		Exhaust valves		0.00 (hot)	0.25 (0.0098) (cold)	0.00 (hot)	0.25 (0.0098) (cold)	0.00 (hot)	0.25 (0.0098) (cold)
	Ignition			Spark	Compression	Spark	Compression	Spark	Compression
	Firing order			1 - 3 - 4 - 2		1 - 3 - 4 - 2		1 - 3 - 4 - 2	
	Ignition timing BTDC		degree/rpm	6/650	–	6/650	–	6/650	–
	Injection timing BTDC		degree	–	18	–	18	–	20
Fuel tank rated capacity		liter (U.S. gal)	53 (14)		53 (14)		76 (20)		

GENERAL INFORMATION

GP25K	DP25K	GP30K	DP35K	GP35K	DP35K
3690 (8140)	3810 (8400)	4240 (9350)	4360 (9610)	4620 (10190)	4740 (10450)
1470 (3240)	1520 (3550)	1780 (3920)	1830 (4040)	1810 (3990)	1850 (4080)
2220 (4900)	2290 (5050)	2460 (5420)	2530 (5580)	2810 (6200)	2890 (6870)
4G63	S4S	4G64	S4S	4G64	S4S
Mitsubishi Motors	MHI	Mitsubishi Motors	MHI	Mitsubishi Motors	MHI
Gasoline	Diesel	Gasoline	Diesel	Gasoline	Diesel
Water		Water		Water	
4 -in-line		4 -in-line		4 -in-line	
4		4		4	
Semi- spherical	Swirl	Semi- spherical	Swirl	Semi- spherical	Swirl
OHC	OHV	OHC	OHV	OHC	OHV
Integral with cylinder block	Dry	Integral with cylinder block	Dry	Integral with cylinder block	Dry
85 × 88 (3.346 × 3.465)	94 × 120 (3.701 × 4.724)	86.5 × 100 (3.406 × 3.937)	94 × 120 (3.701 × 4.724)	86.5 × 100 (3.406 × 3.937)	94 × 120 (3.701 × 4.724)
1997 (121.8)	3331 (203.2)	2350 (143.4)	3331 (203.2)	2350 (143.4)	3331 (203.2)
8.5 : 1	22 : 1	8.6 : 1	22 : 1	8.6 : 1	22 : 1
42/2400	60/2200	50/2400	60/2200	50/2400	60/2200
134 (13.7) [99]/1600	201 (20.5) [148]/1400	167 (17) [123]/1600	201 (20.5) [148]/1400	167 (17) [123]/1600	201 (20.5) [148]/1400
653 × 604 × 759 (25.7 × 23.8 × 29.9)	647 × 552 × 712 (25.5 × 21.7 × 28)	653 × 604 × 759 (25.7 × 23.8 × 29.9)	647 × 552 × 712 (25.5 × 21.7 × 28)	653 × 604 × 759 (25.7 × 23.8 × 29.9)	647 × 552 × 712 (25.5 × 21.7 × 28)
150 (330)	260 (570)	150 (330)	260 (570)	150 (330)	260 (570)
Rear		Rear		Rear	
12	30	12	30	12	30
40	50	40	50	40	50
54	74	54	74	54	74
6	30	6	30	6	30
0.00 (hot)	0.25 (0.0098) (cold)	0.00 (hot)	0.25 (0.0098) (cold)	0.00 (hot)	0.25 (0.0098) (cold)
0.00 (hot)	0.25 (0.0098) (cold)	0.00 (hot)	0.25 (0.0098) (cold)	0.00 (hot)	0.25 (0.0098) (cold)
Spark	Compression	Spark	Compression	Spark	Compression
1 - 3 - 4 - 2		1 - 3 - 4 - 2		1 - 3 - 4 - 2	
6/650	–	6/650	–	6/650	–
–	20	–	20	–	20
76 (20)		76 (20)		76 (20)	

Thank you so much for reading.
Please click the “Buy Now!”
button below to download the
complete manual.



After you pay.

You can download the most
perfect and complete manual in
the world immediately.

Our support email:

ebooklibonline@outlook.com