



Service Manual

Chassis, Mast & Attachments

DP60	T20C-10001-up
DP70	T20C-60001-up

FOREWORD

This service manual is a guide for servicing Cat[®] lift trucks. For your convenience the instructions are grouped by systems as a ready reference.

The long productive life of your lift truck(s) depends on regular and proper servicing. Servicing consistent with what you will learn by reading this service manual.

Read the respective sections of this manual carefully and familiarize yourself with all of the components before attempting to start a test, repair or rebuild job.

The descriptions, illustrations and specifications contained in this manual are for trucks with serial numbers in effect at the time of printing. Cat Lift Trucks reserves the right to change specifications or design without notice and without incurring obligation.

The trucks listed in this manual are powered by S6S diesel engines. For the engine servicing, please refer to the applicable engine service manual.



Indicates a potentially hazardous situation which, if not avoided, could result in death or serious injury.



Indicates a potentially hazardous situation which, if not avoided, may result in death or serious injury or damage to the machine.

NOTE

Indicates a condition that can cause damage to, or shorten service life of, the lift truck.

This document shall not be transferred, rented, or reproduced to a third party without permission.

 **WARNING**

The proper and safe lubrication and maintenance for these lift trucks, recommended by Cat Lift Trucks, are outlined in the OPERATION & MAINTENANCE MANUAL for these trucks.

Improper performance of lubrication or maintenance procedures is dangerous and could result in injury or death. Read and understand the OPERATION & MAINTENANCE MANUAL before performing any lubrication or maintenance on these trucks.

The serviceman or mechanic may be unfamiliar with many of the systems on this truck. This makes it important to use caution when performing service work. A knowledge of the system and/or components is important before the removal or disassembly of any component.

Because of the size of some of the truck components, the serviceman or mechanic should check the weights noted in this Manual. Use proper lifting procedures when removing any components.

Following is a list of basic precautions that should always be observed.

- (1) Read and understand all warning plates and decals on the truck before operating, lubricating or repairing the product.
- (2) Always wear protective glasses and protective shoes when working around trucks. In particular, wear protective glasses when pounding on any part of the truck or its attachments with a hammer or sledge. Use welders gloves, hood/goggles, apron and other protective clothing appropriate to the welding job being performed. Do not wear loose-fitting or torn clothing. Remove all rings from fingers when working on machinery.
- (3) Do not work on any truck that is supported only by lift jacks or a hoist. Always use blocks or jack stands to support the truck before performing any disassembly.
- (4) Lower the forks or other implements to the ground before performing any work on the truck. If this cannot be done, make sure the forks or other implements are blocked correctly to prevent them from dropping unexpectedly.
- (5) Use steps and grab handles (if applicable) when mounting or dismounting a truck. Clean any mud or debris from steps, walkways or work platforms before using. Always face truck when using steps, ladders and walkways. When it is not possible to use the designed access system, provide ladders, scaffolds, or work platforms to perform safe repair operations.

 **WARNING**

Do not operate these trucks unless you have read and understood the instructions in the OPERATION & MAINTENANCE MANUAL. Improper truck operation is dangerous and could result in injury or death.

- (6) To avoid back injury, use a hoist when lifting components which weight 23 kg (50 lb.) or more. Make sure all chains, hooks, slings, etc., are in good condition and are of the correct capacity. Be sure hooks are positioned correctly. Lifting eyes are not to be side loaded during a lifting operation.
- (7) To avoid burns, be alert for hot parts on trucks which have just been stopped and hot fluids in lines, tubes and compartments.
- (8) Be careful when removing cover plates. Gradually back off the last two bolts or nuts located at opposite ends of the cover or device and pry cover loose to relieve any spring or other pressure, before removing the last two bolts or nuts completely.
- (9) Be careful when removing filler caps, breathers and plugs on the truck. Hold a rag over the cap or plug to prevent being sprayed or splashed by liquids under pressure. The danger is even greater if the truck has just been stopped because fluids can be hot.
- (10) Always use tools that are in good condition and be sure you understand how to use them before performing any service work.
- (11) Reinstall all fasteners with same part number. Do not use a lesser quality fastener if replacements are necessary.
- (12) If possible, make all repairs with the truck parked on a level, hard surface. Block truck so it does not roll while working on or under truck.
- (13) Disconnect battery and discharge any capacitors (electric trucks) before starting to work on truck. Hang "Do not Operate" tag in the Operator's Compartment.

-
- (14) Repairs, which require welding, should be performed only with the benefit of the appropriate reference information and by personnel adequately trained and knowledgeable in welding procedures. Determine type of metal being welded and select correct welding procedure and electrodes, rods or wire to provide a weld metal strength equivalent at least to that of parent metal.
 - (15) Do not damage wiring during removal operations. Reinstall the wiring so it is not damaged nor will it be damaged in operation by contacting sharp corners, or by rubbing against some object or hot surface. Place wiring away from oil pipe.
 - (16) Be sure all protective devices including guards and shields are properly installed and functioning correctly before starting a repair. If a guard or shield must be removed to perform the repair work, use extra caution.
 - (17) Always support the mast and carriage to keep carriage or attachments raised when maintenance or repair work is performed, which requires the mast in the raised position.
 - (18) Loose or damaged fuel, lubricant and hydraulic lines, tubes and hoses can cause fires. Do not bend or strike high pressure lines or install ones which have been bent or damaged. Inspect lines, tubes and hoses carefully. Do not check for leaks with your hands. Pin hole (very small) leaks can result in a high velocity oil stream that will be invisible close to the hose. This oil can penetrate the skin and cause personal injury. Use cardboard or paper to locate pin hole leaks.
 - (19) Tighten connections to the correct torque. Make sure that all heat shields, clamps and guards are installed correctly to avoid excessive heat, vibration or rubbing against other parts during operation. Shields that protect against oil spray onto hot exhaust components in event of a line, tube or seal failure, must be installed correctly.
 - (20) Relieve all pressure in air, oil or water systems before any lines, fittings or related items are disconnected or removed. Always make sure all raised components are blocked correctly and be alert for possible pressure when disconnecting any device from a system that utilizes pressure.
 - (21) Do not operate a truck if any rotating part is damaged or contacts any other part during operation. Any high speed rotating component that has been damaged or altered should be checked for balance before reusing.

HOW TO READ THIS MANUAL (Mounting, Dismounting, Disassembly, and Assembly)

Disassembly

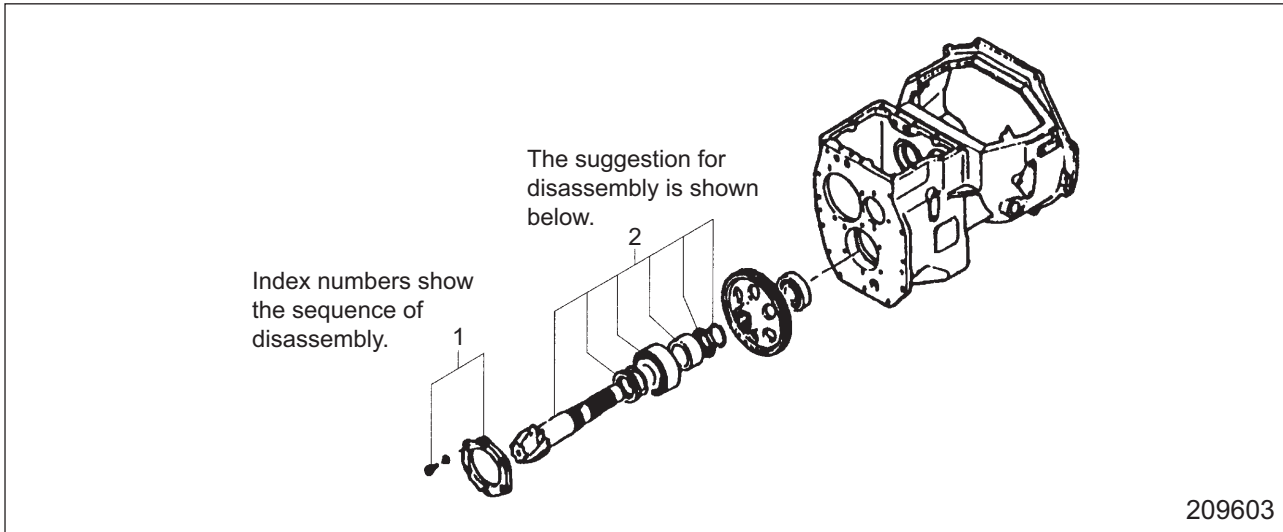

Disassembly sequence

- (1) Bolt, Washer, Cover (part name)
- (2) Snap ring, Output shaft (part name)

Suggestion for disassembly

- (1) Output shaft removal
Use the special tools to remove output shaft.

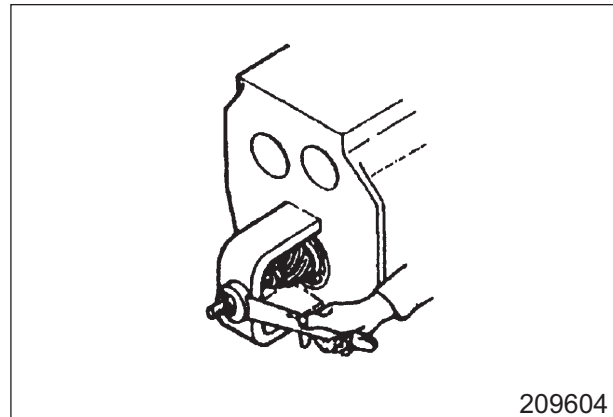

Service data provided in this manual

Clearance between cylinder body and piston	Standard value	0.020 to 0.105 mm (0.00079 to 0.00413 in.)
	Repair or service limit	0.15 mm (0.059 in.)

Symbols or abbreviations

OP Option

R1/4 Taper pipe thread (external) 1/4 inch (formerly PT1/4)

Rc1/8 Taper pipe thread (internal) 1/8 inch (formerly PT1/8)

G1/4A Straight pipe thread (external) 1/4 inch (formerly PF1/4-A)

Rp1/8 Straight pipe thread (internal) 1/8 inch (formerly PS1/8)

Units

- SI Units are used in this manual.
- The following table shows the conversion of SI unit and customary unit.

Item	SI unit	Customary unit
Force	1 N	0.1020 kgf
Pressure	1 kPa	0.0102 kgf/cm ²
Torque	1 N•m	0.1020 kgf•m

GROUP INDEX

GROUP INDEX	Items	
GENERAL INFORMATION	Model View, Truck Models Covered, Serial Number Locations, Main Specifications, Chassis and Mast Model Identification, Dimensions	1
COOLING SYSTEM	Specifications, Structure, Suggestions for Removal and Installation, Inspection and Adjustment	2
ELECTRICAL SYSTEM	Specifications, Location of Components, Structure, Disassembly and Reassembly, Batteries and Charging, Troubleshooting, Electrical Wiring Diagram	3
POWER TRAIN	Specifications, Structure, Reduction Ratio, Removal and Installation of Engine and Transmission Unit	4
POWERSHIFT TRANSMISSIONS	Specifications, Structure, Suggestions for Removal and Installation, Disassembly and Reassembly, Readjust, Troubleshooting, Service Data	5
FRONT AXLE AND REDUCTION DIFFERENTIAL	Specifications, Structure, Suggestions for Removal and Installation, Disassembly and Reassembly, Troubleshooting, Service Data	6
REAR AXLE	Specifications, Description, Removal and Installation, Disassembly and Reassembly, Adjusting, Troubleshooting, Service Data	7
BRAKE SYSTEM	Specifications, Structure, Disassembly and Reassembly, Adjustment and Testing, Troubleshooting, Service Data	8
STEERING SYSTEM	Specifications, Structure and Functions, Removal and Installation, Disassembly and Reassembly, Troubleshooting, Service Data	9
HYDRAULIC SYSTEM	Specifications, Structure and Functions, Removal and Installation, Disassembly and Reassembly, Inspection and Adjustment, Testing, Troubleshooting, Service Data	10
MASTS AND FORKS	Specifications, Structure, Operation of Triplex Mast, Suggestions for Removal and Installation, Disassembly and Reassembly, Chain Adjustment, Troubleshooting, Service Data	11
FORK POSITIONER	Applicable Attachment Models, Specifications, Structure, Suggestions for Removal and Installation, Disassembly and Reassembly, Troubleshooting, Service Data	12
SIDE SHIFTER	Applicable Attachment Models, Specifications, Structure, Suggestions for Removal and Installation, Disassembly and Reassembly, Troubleshooting, Service Data	13
SERVICE DATA	Inspection Point, Tightening Torque of Standard Bolts, Periodic Replacement Parts, Lubrication Standards, Weight of Major Components, Special Tools	14

GENERAL INFORMATION

1. Model View.....	1-2
2. Truck Models Covered	1-2
3. Serial Number Locations.....	1-3
4. Main Specifications	1-4
5. Chassis and Mast Model Identification.....	1-5
6. Dimensions	1-6

1. Model View

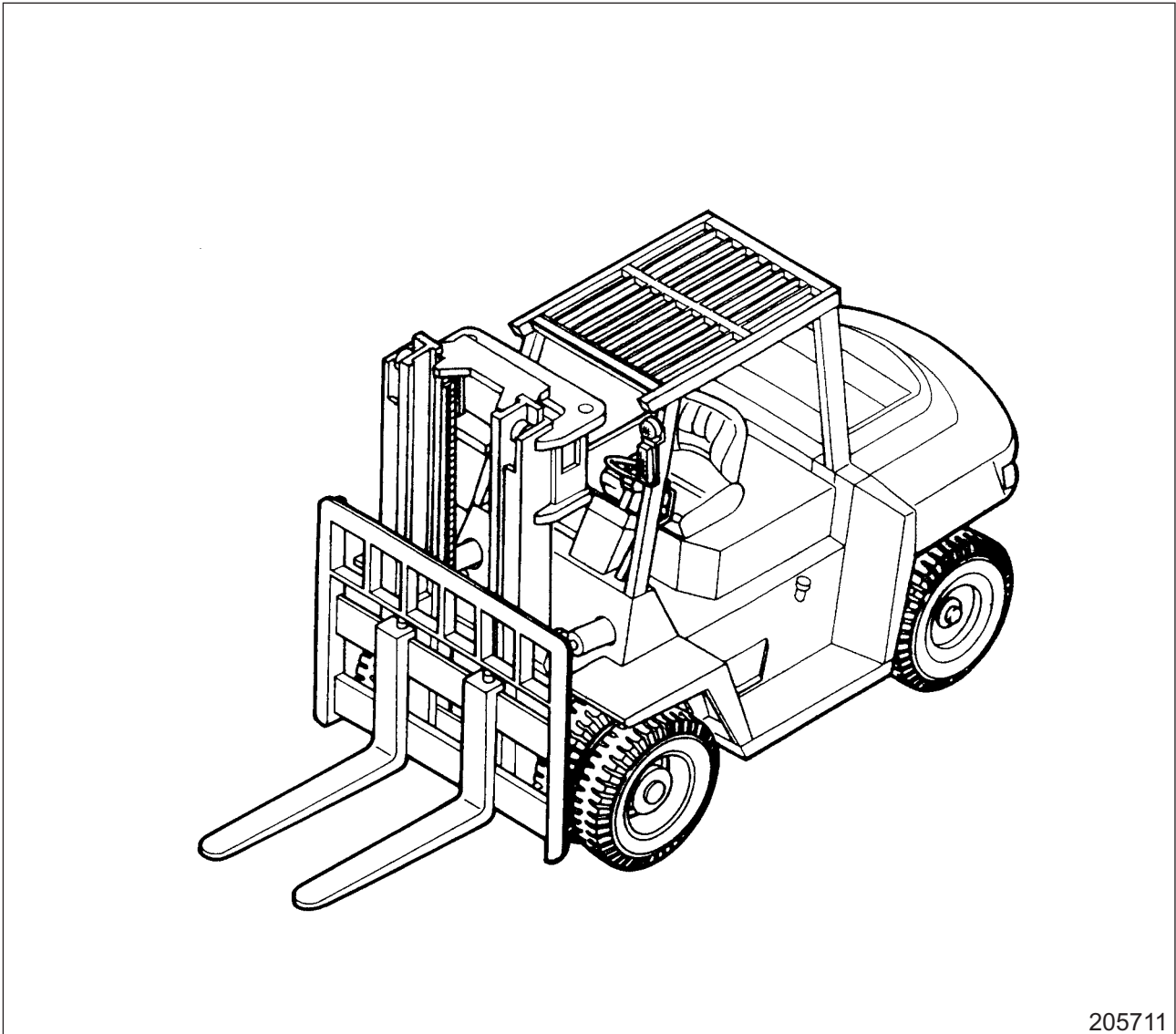

205711

2. Truck Models Covered

This Service Manual applies to the following truck models (common names).

Truck model	Transmission	Model code - Serial number	Engine mounted
DP60	Torque converter drive transmission	T20C-10001-up	Mitsubishi S6S diesel engine
DP70	Torque converter drive transmission	T20C-60001-up	Mitsubishi S6S diesel engine

3. Serial Number Locations

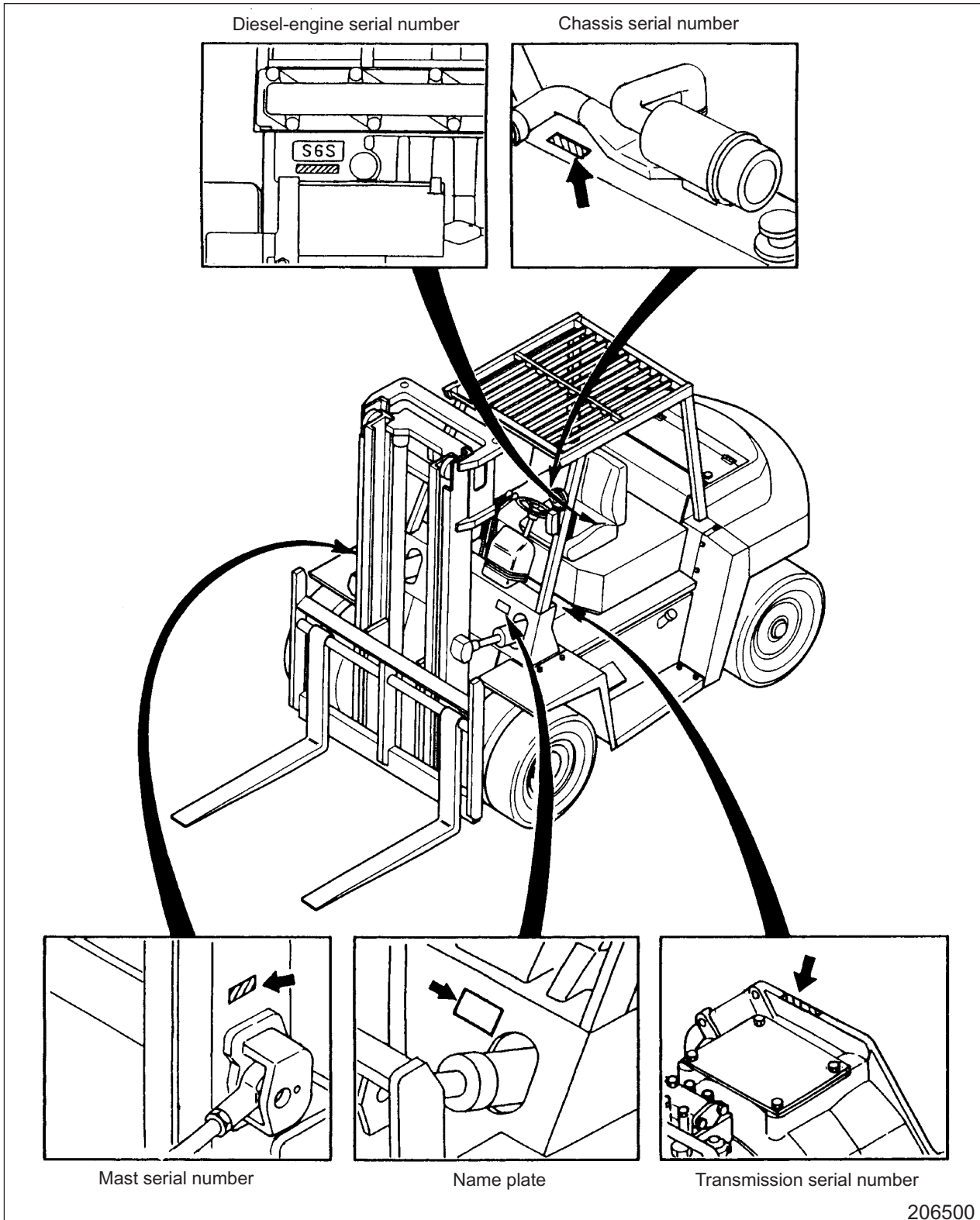

4. Main specifications

Truck model		DP60	DP70
Truck Model		Cat T20C	
Type		Standard (with 2-speed powershift transmission)	
Capacity/load center		6000/600 kgf/mm (13228/24 lbf/in.)	7000/600 kgf/mm (15432/24 lbf/in.)
Lift, maximum		3300 mm (130 in.)	
Lift speed (unloaded/loaded)		470/440 mm/sec (93/87 fpm)	
Lowering speed (unloaded/loaded)		550 mm/sec (108 fpm)	
Mast tilt angle (forward-backward)		6°–12°	
Free lift		205 mm (8.1 in.)	
Forward travel speed (1st/2nd)		10/27.5 km/h (6.2/17.1 mph)	
Reverse travel speed (1st/2nd)			
Minimum turning radius		3310 mm (130.3 in.)	3395 mm (133.7 in.)
Minimum intersecting aisle		3000 mm (118.1 in.)	3050 mm (120 in.)
Front wheel (double-tire)	Size	8.25-15-12PR (1)	
	Inflation	0.7MPa (7kgf/cm ²) [101 psi]	
Rear wheel	Size	8.25-15-12PR (1)	
	Inflation	0.7MPa (7kgf/cm ²) [101 psi]	
Relief-valve setting of power steering		10.8 MPa (110 kgf/cm ²) [1567 psi]	
Relief-valve setting of control valve		19.1 MPa (195 kgf/cm ²) [2770 psi]	
Truck weight		8710 kg (19200 lb)	9320 kg (20546 lb)

5. Chassis and Mast Model Identification

[Chassis]

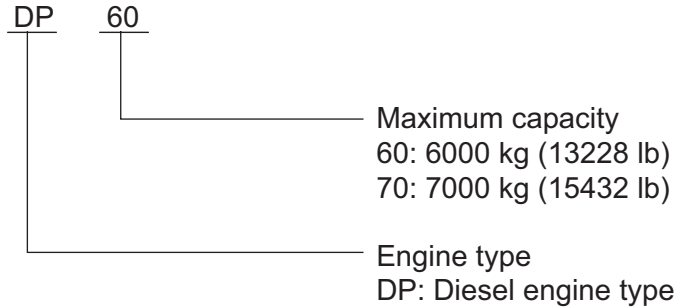

[Mast]

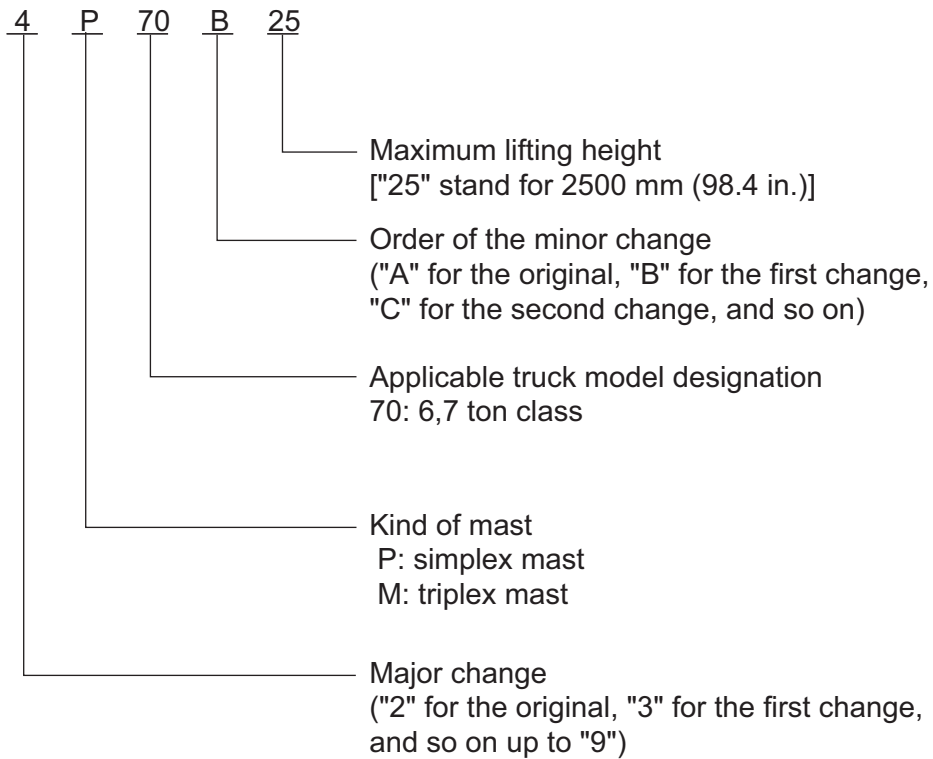

6. Dimensions

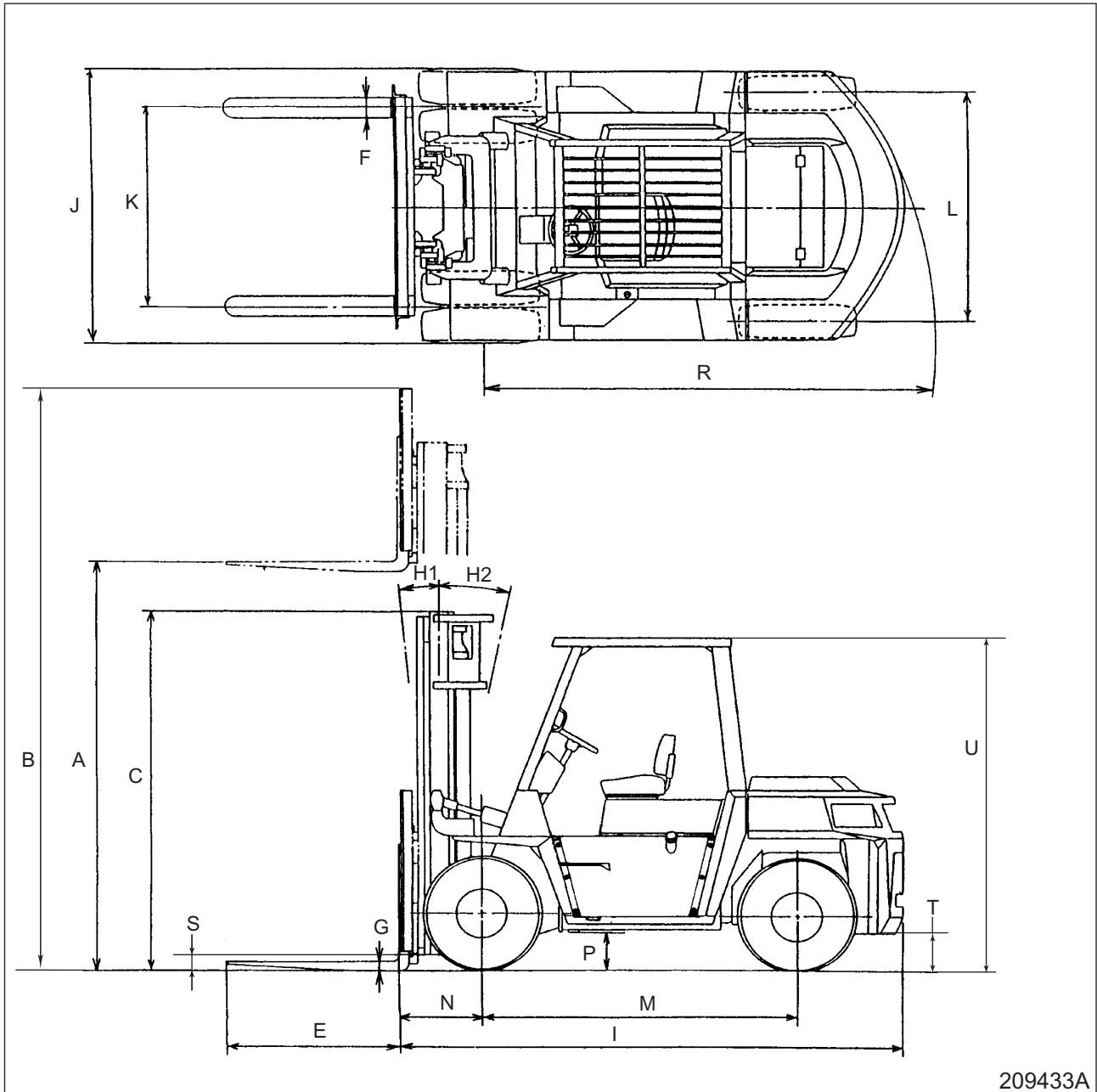

209433A

No.	Truck model	DP60	DP70
A	Maximum lift	3300 mm (130 in.)	
B	Overall height at maximum lift	4580 mm (180.3 in.)	
C	Overall mast height Height of mast lowered	2720 mm (107.1 in.)	
D	Free lift	205 mm (8.1 in.)	
E	Fork length	1220 mm (48 in.)	
F	Fork width	150 mm (5.9 in.)	
G	Fork thickness	65 mm (2.36 in.)	
H1, H2	Mast tilt angle (forward-backward)	6°–12°	
I	Truck length	4805 mm (189.2 in.)	4855 mm (191.1 in.)
J	Overall width (outside of tires)	2170 mm (85.4 in.)	
K	Tread (front wheel)	1650 mm (65 in.)	
L	Tread (rear wheel)	1650 mm (65 in.)	
M	Wheelbase	2300 mm (90.6 in.)	
N	Front overhang	586 mm (23 in.)	
P	Minimum height from ground	265 mm (10.4 in.)	
R	Minimum radius	3310 mm (130 in.)	3395 mm (134 in.)
S	Underclearance (at mast)	170 mm (6.7 in.)	
T	Underclearance (at counterweight)	240 mm (9.5 in.)	
U	Overall height (head-guard height)	2420 mm (95.3 in.)	

COOLING SYSTEM

1. Specifications	2-2
2. Structure.....	2-3
3. Suggestions for Removal and Installation.....	2-4
3.1 Removing Fan Belt	2-4
3.1.1 Suggestions for Removal and Installation.....	2-4
3.1.2 Procedure involving removal of counterweight	2-6
3.1.3 Suggestions for Removal and installation	2-7
3.1.4 Installation	2-7
4. Inspection and Adjustment.....	2-8
4.1 Inspection of Fan Belt	2-8
4.2 Fan Belt Tension Adjustment.....	2-8

1. Specifications

Truck model	DP60	DP70
Cooling method	Forced circulation of coolant	
Radiator type	Corrugated fins with pressure cap	
Total coolant capacity	18 L (1098 cu.in.) [4.7 U. S. gal.]	
Water pump type	Volute type, V-belt driven	
Thermostat type	Wax pellet	

2. Structure

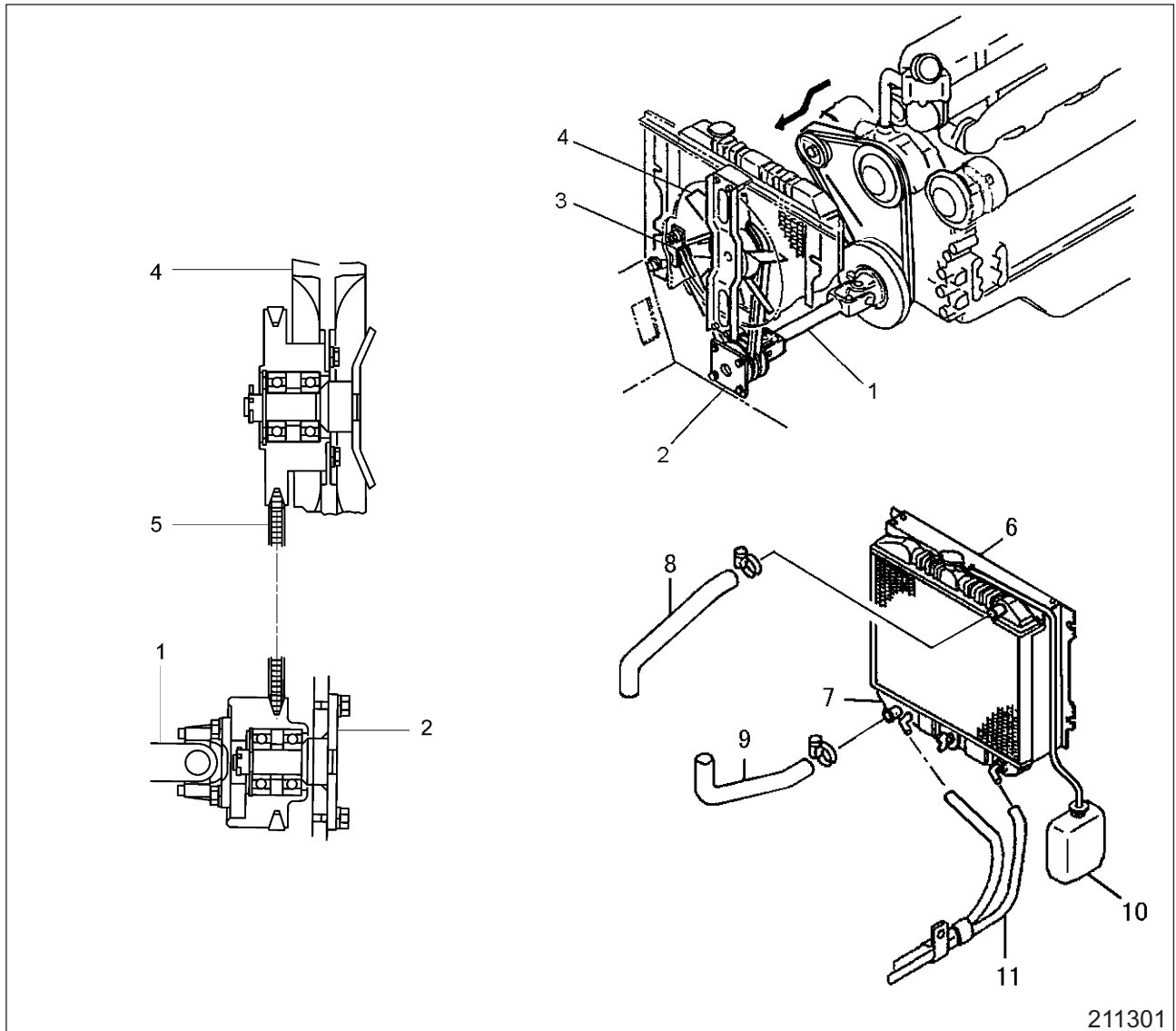

- 1 Universal joint
- 2 Pulley boss
- 3 Tensioner pulley
- 4 Cooling fan
- 5 Fan belt
- 6 Radiator

- 7 Transmission oil cooler
- 8 Upper hose
- 9 Lower hose
- 10 Reserve tank
- 11 Transmission oil hose

The cooling system features a reserve tank as standard equipment and an arrangement that facilitates adjustment of the fan belt tension.

The system incorporates a transmission oil cooler.

3. Suggestions for Removal and Installation

3.1 Removing Fan Belt

3.1.1 Suggestions for Removal and Installation

- (1) Preparation
 - (a) Remove the radiator cover.
 - (b) Remove the engine cover and gas springs.

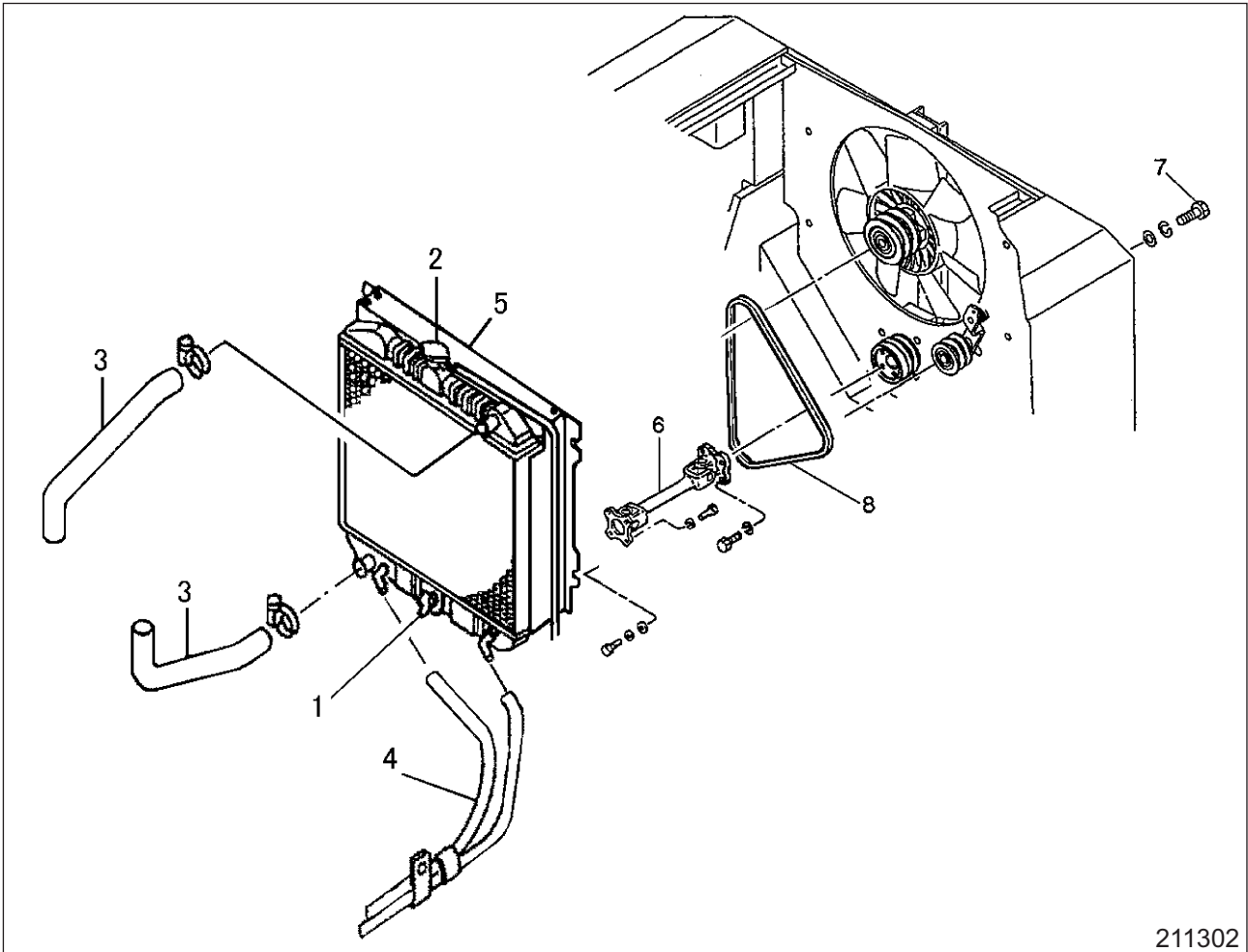

211302

(2) Removal sequence

- | | |
|-------------------------------|---------------------------------|
| 1 Drain cock | 5 Radiator |
| 2 Cap | 6 Universal joint |
| 3 Hose (for coolant) | 7 Tensioner pulley locking bolt |
| 4 Hose (for transmission oil) | 8 Fan belt |

(3) Suggestions for Removal

- (a) Make sure that engine coolant is not hot, then open the drain cock to allow the coolant to be drained.
- (b) Insert Ratchet Wrench A through the adjusting hole in the frame and loosen the tensioner pulley locking bolt one or two turns. With a claw bar move the tensioner pulley as far as possible to the fan side, then tighten the tensioner pulley locking bolt so that the fan belts can be easily removed.

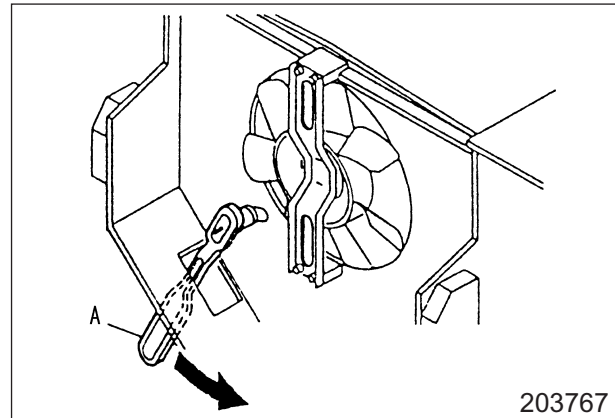

(4) Installation

Follow the removal procedure in reverse while noting the following instructions.

- (a) Check the fan bearing for smooth rotation with the belt removed. Replace the bearing if it generates abnormal sound.
- (b) Install the belt and push it at a point midway between the driven and drive pulleys to make sure that the tensioner pulley moves, then tighten the pulley lock bolt firmly.
- (c) Connect each hose to the radiator making sure that the end of the hose reaches the root of the fitting. Tighten the clamp and make sure the hose end is stopped at the flare of the fitting.
- (d) Pour antifreeze and coolant into the radiator and start the engine. Warm-up the engine while checking for abnormal sound. Check the reserve tank to see whether it is filled with the given quantity of coolant.

Thank you so much for reading.
Please click the “Buy Now!”
button below to download the
complete manual.



After you pay.

You can download the most
perfect and complete manual in
the world immediately.

Our support email:

ebooklibonline@outlook.com