



Service Repair Manual

Models

160H Motor Grader

Product: MOTOR GRADER

Model: 160H MOTOR GRADER CCP

Configuration: 160H Motor Grader CCP0001-UP (MACHINE) POWERED BY 3176C Engine

Disassembly and Assembly 12H, 140H and 160H Motor Graders Machine Systems

Media Number -REN4124-06

Publication Date -01/09/2007

Date Updated -24/09/2007

i07430989

Piston Pump (Hydraulic and Steering) - Assemble

SMCS - 4306-016; 5070-016

Assembly Procedure

Table 1

Required Tools			
Tool	Part Number	Part Description	Qty
B	1P-1861	Retaining Ring Pliers	1
D	1P-0510	Driver Group	1
E	8T-5096	Dial Indicator Group	1
F	-	Loctite LB 8632 Silicone Lubricant ⁽¹⁾	-
	-	Loctite LB 8104 Silicone Lubricant ⁽²⁾	-
	-	Loctite LB 8801 Silicone Lubricant ⁽³⁾	-
	-	Loctite LB Superlube ⁽⁴⁾	-
G	-	Loctite 243	-

⁽¹⁾ North America

⁽²⁾ EAME

⁽³⁾ Asia Pacific Division

⁽⁴⁾ South America

Note: The axial end play must be adjusted if the swashplate, the swashplate bearings, the shaft, the shaft bearings, the head, or the housing has been replaced.

1. During the assembly of the piston pump, check the condition of all the O-ring seals and the lip seals that are used in the pump. If any of these seals are damaged, use new parts for replacement.

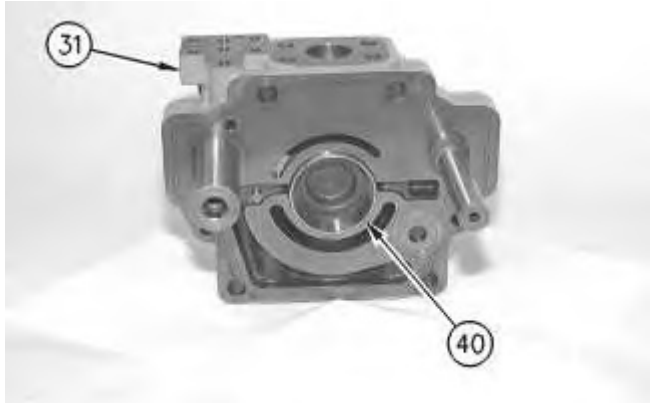

Illustration 1

g00991054

2. Lower the temperature of bearing cup (40). Use Tooling (D) to install bearing cup (40) in head (31). Install bearing cup (40) until the bearing cup is seated.

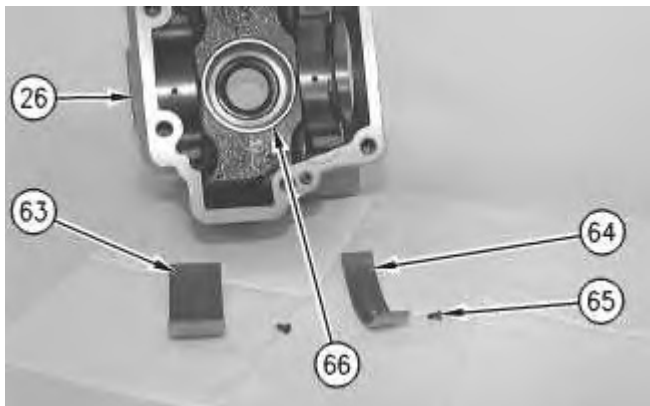

Illustration 2

g00990468

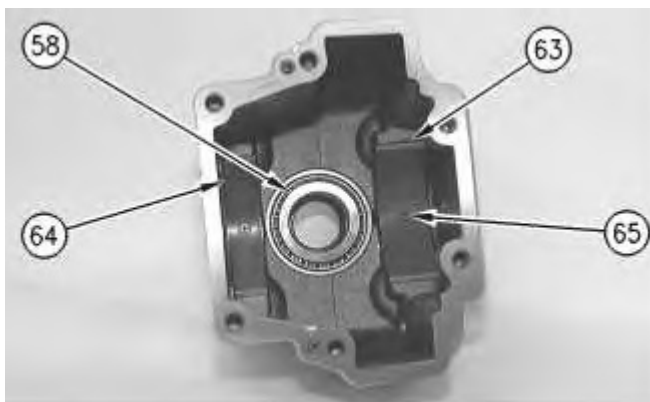

Illustration 3

g00990696

3. Lower the temperature of bearing cup (66). Use Tooling (D) to install bearing cup (66) in housing (26). Install bearing cup (66) until the bearing cup is seated.
4. Install bearing (58) in housing (26).

5. Install bearing (63) and bearing (64) into housing (26). Install set screws (65).

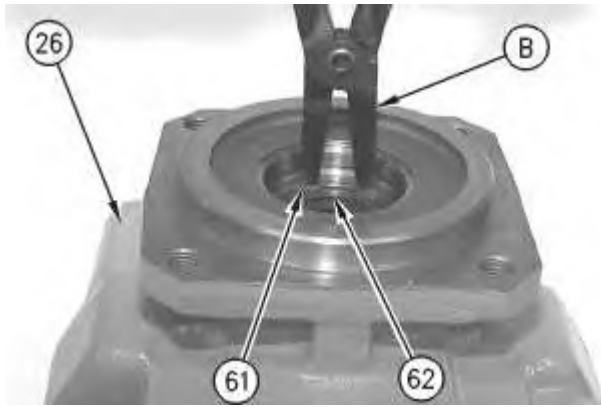

Illustration 4

g00990391

6. Use Tooling (D) to install lip seal (62) in housing (26) until the lip seal is seated. The sealing lip must face inward. Lubricate the sealing lip lightly with hydraulic oil before installation. Use Tooling (B) to install retaining ring (61) into housing (26).

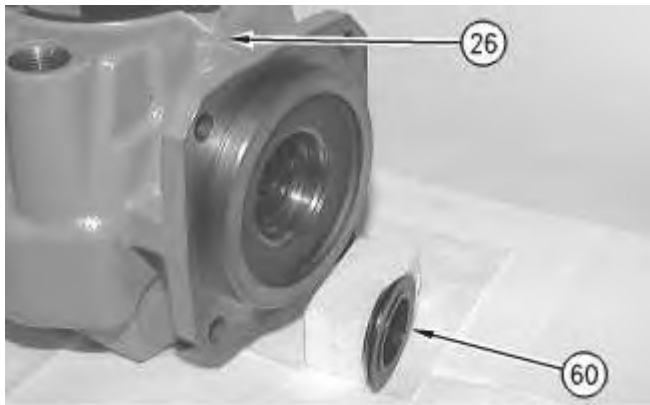

Illustration 5

g00990390

7. Install shield (60) into housing (26).

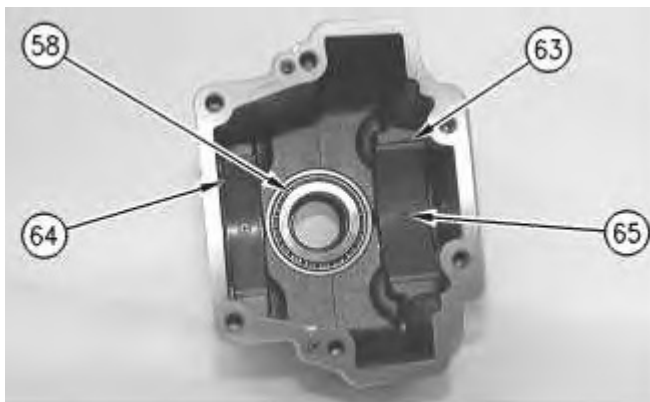

Illustration 6

g00990696

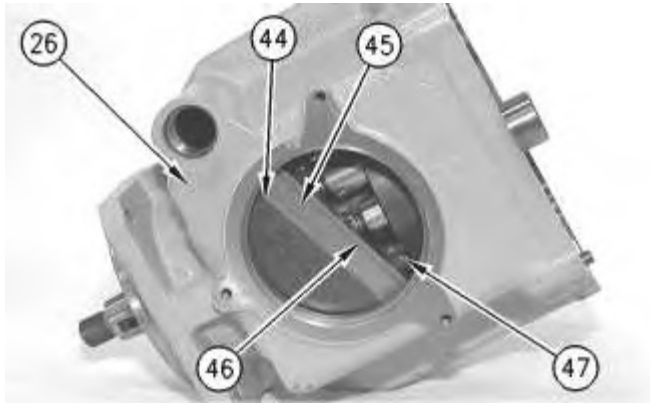

Illustration 7

g00990376

8. Place a light coat of hydraulic oil on bearing (64) and bearing (65). The hydraulic oil will hold swashplate (54) in position during the following steps. Install swashplate (44) into housing (26). Swashplate (44) should fit into bearing (64) and bearing (65).

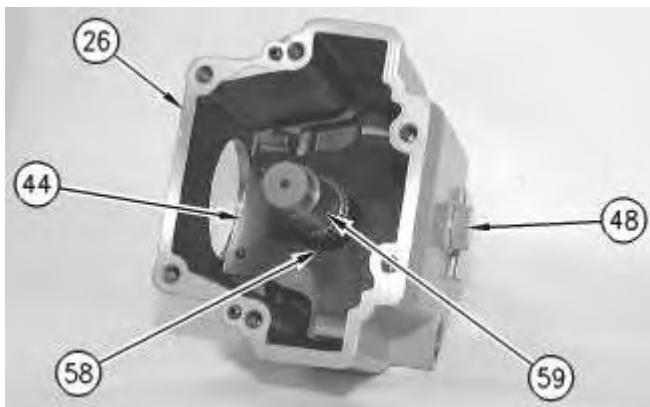

Illustration 8

g00990697

9. Place housing (26) onto support blocks to allow space for installation of shaft (59). Shaft (59) extends beyond the end of housing (26). Install shaft (59) through swashplate (44), through bearing (58) (not shown), and through housing (26).
10. Install plug (48) into housing (26). Install the O-ring seal into housing (26).

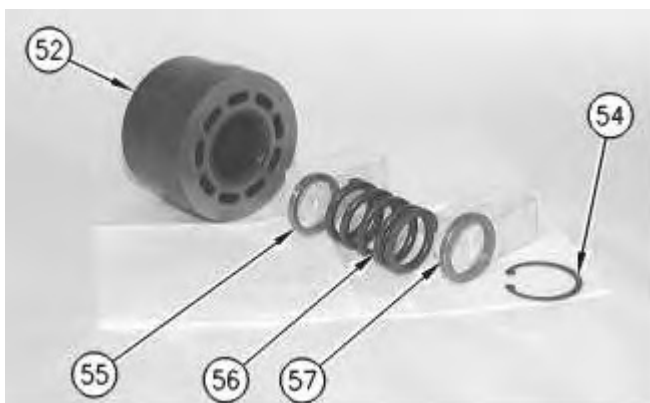

Illustration 9

g00990382

Thank you so much for reading.
Please click the “Buy Now!”
button below to download the
complete manual.



After you pay.

You can download the most
perfect and complete manual in
the world immediately.

Our support email:

ebooklibonline@outlook.com