



# Service Repair Manual

## **Model**

**226B3 SKID STEER LOADER**

---

Product: SKID STEER LOADER

Model: 226B3 SKID STEER LOADER SNA

Configuration: 226B3 Skid Steer Loader SNA00001-UP (MACHINE) POWERED BY C2.2 Engine

## Disassembly and Assembly

### 259B3 Compact Track Loader, 247B3 and 257B3 Multi Terrain Loaders and 216B3, 226B3, 236B3, 242B3 and 252B3 Skid Steer Loaders Power Train

Media Number -UENR0251-07

Publication Date -01/07/2018

Date Updated -11/07/2018

i02362815

## Piston Pump (Hydrostatic) - Assemble

SMCS - 5070-016-H7

### Assembly Procedure

Table 1

Required Tools			
Tool	Part Number	Part Description	Qty
A	9U-7289	Ruler	1
B	1P-1861	Retaining Ring Pliers	1
F	1P-0510	Driver Gp	1
G	1P-1854	Retaining Ring Pliers	1
J	1P-1860	Retaining Ring Pliers	1
K	8H-0663	Bearing Puller Gp	1
L	2P-8301	Seal Guide	1
M	6V-2055	Grease	1
N	1U-6395	Grease	1
P	9S-3263	Thread Lock Compound	1

---

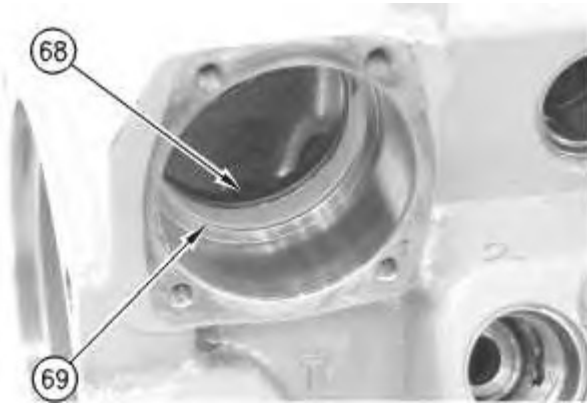

---

Illustration 1

g00906515

1. Install liner (69).
  2. Install seal (68).
- 



---

Illustration 2

g00906511

3. Install actuator (67).
- 

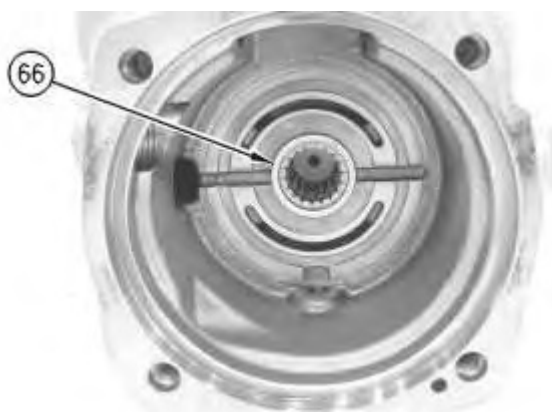

---

Illustration 3

g00906134

4. Install bearing (66).
-

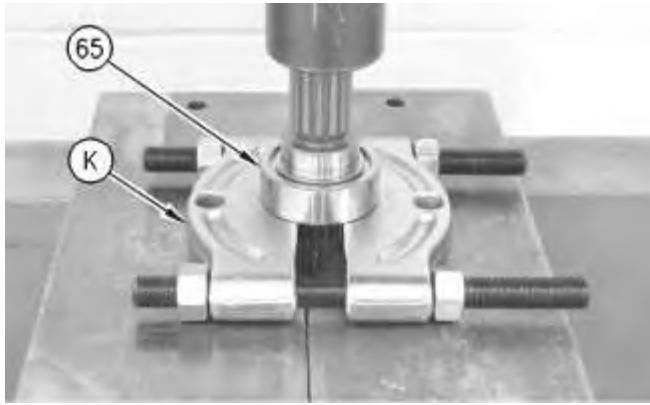

Illustration 4

g00906130

5. Raise the temperature of bearing (65).
6. Use a suitable press and Tooling (K) to install bearing (65).

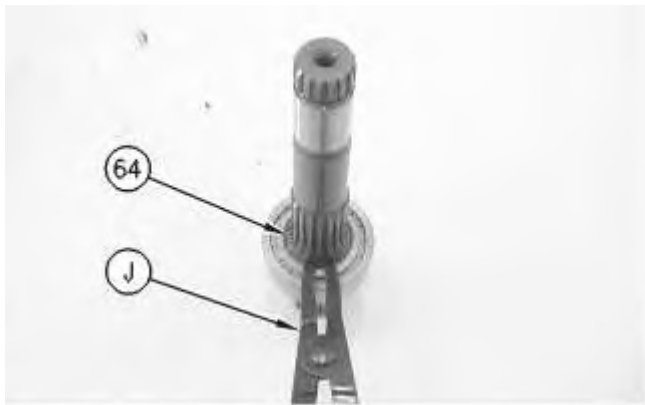

Illustration 5

g00905698

7. Use Tooling (J) to install retaining ring (64).

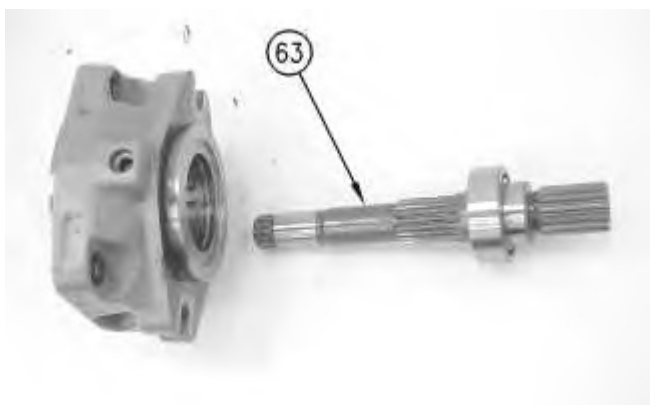
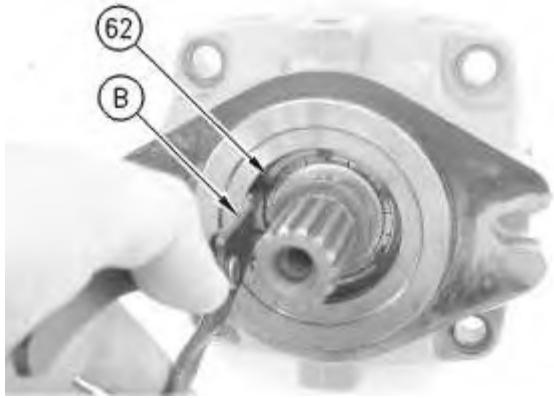

Illustration 6

g00905653

8. Install shaft (63).



---

Illustration 7

g00905582

9. Use Tooling (B) to install retaining ring (62).
- 



---

Illustration 8

g00905650

10. Dowel (59) must be aligned with the piston pump housing during assembly.  
11. Install O-ring seal (58).
- 



---

Illustration 9

g00905648

12. Install bearing races (56) on pins (57).
-

Thank you so much for reading.  
Please click the “Buy Now!”  
button below to download the  
complete manual.



After you pay.

You can download the most  
perfect and complete manual in  
the world immediately.

Our support email:

[ebooklibonline@outlook.com](mailto:ebooklibonline@outlook.com)