



# Service Repair Manual

## **Model**

**235C EXCAVATOR**

---

Product: EXCAVATOR

Model: 235C EXCAVATOR 3WG

Configuration: 235C EXCAVATOR 3WG00001-UP (MACHINE) POWERED BY 3306 ENGINE

## Disassembly and Assembly 3306 VEHICULAR ENGINE FOR 235C & 235D EXCAVATOR

Media Number -SEN3833-01

Publication Date -01/12/1991

Date Updated -11/10/2001

### Fuel Injection Pumps

SMCS - 1251-011; 1251-012; 1251-017

### Remove Fuel Injection Pumps

Tools Needed		A	B	C
6V4186	Timing Pin	1		
8S4613	Wrench		1	
8S2244	Extractor			1

Start By:

- a. remove governor \*

\*See Governor, Disassemble & Assemble

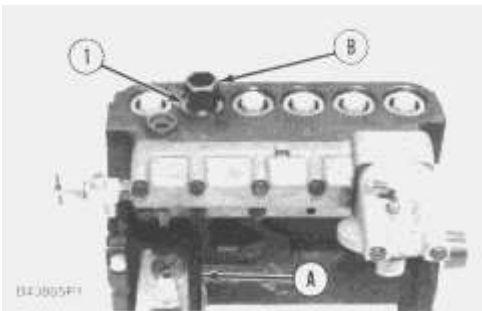

1. Remove the bolts and the plate from side of the fuel injection pump housing.
2. Install tool (A) in the fuel injection pump housing. Move the rack until tool (A) can be installed to hold the rack in the center position. The rack must be in the center position to remove the fuel injection pumps.
3. Use tool (B) to remove bushing (1) from the fuel injection pump housing.
4. Remove the O-ring seal from the fuel injection pump housing.

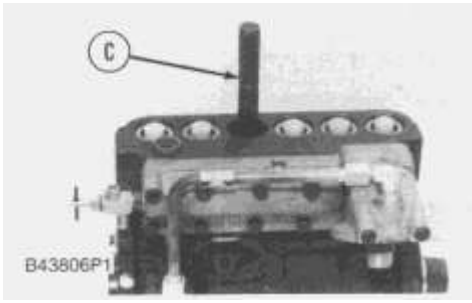

5. Install tool (C) on the bonnet and remove the fuel injection pump.

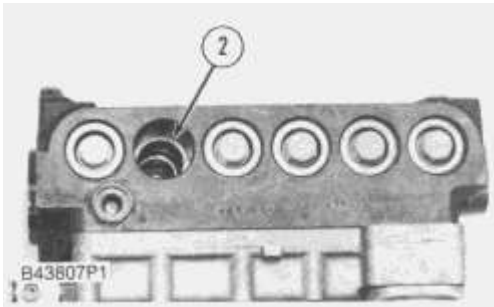

6. Remove spacer (2) from the fuel injection pump housing.

**NOTE:** Spacers (2) are the same thickness for each fuel injection pump so they can be mixed. The fuel injection pump plungers and barrels are in sets and can not be mixed.

7. Do Steps 3 through 6 to remove the other fuel injection pumps.

## Install Fuel Injection Pumps

Tools Needed		A	B	C	D
6V4186	Timing Pin	1			
8S4613	Wrench		1		
8S2244	Extractor			1	
9S0228	Rack Position Tool Group				1
3S3270	1 in Contact Tip				1
	C-Clamp				1

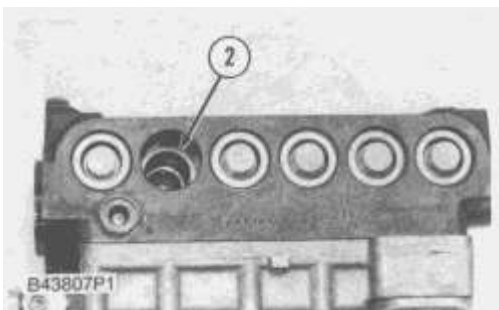

1. Install spacer (2) in the fuel injection pump housing.

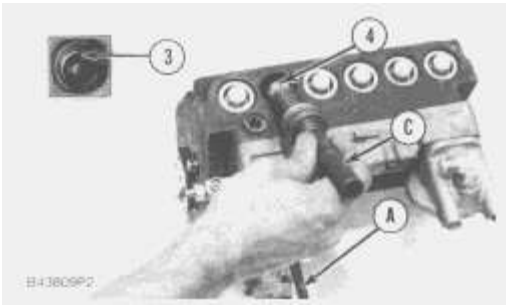

2. Install tool (A) in the fuel injection pump housing. Move the rack until tool (A) can be installed to hold the rack in the center position. The rack must be in the center position to install the fuel injection pumps.

3. Turn camshaft until the lobe of the camshaft is down for the pump to be installed.

4. Install tool (C) on the bonnet of the fuel injection pump.

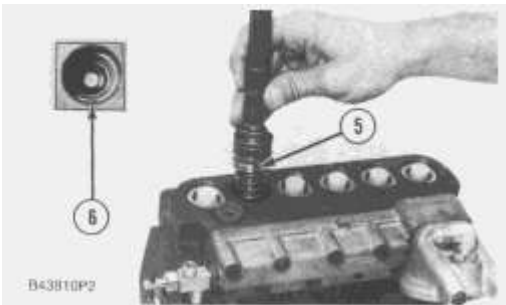

5. Install the fuel injection pump in the pump housing with saw cut (slot (4) in the gear in alignment with the small pin (3), and groove (5) in the barrel in alignment with dowel (6) in the pump housing.

6. Put clean oil on the O-ring seal and install it in the fuel injection pump housing.

7. Install the bushing by hand until the bushing is even with the top of the housing. If the bushing can not be installed this far by hand, remove it. Remove the fuel injection pump and put the pump in alignment again and install the bushing again.

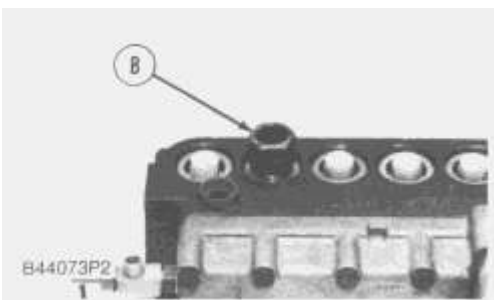

8. Install tool (B) on the bushing and tighten the bushing to a torque of  $190 \pm 14 \text{ N}\cdot\text{m}$  ( $140 \pm 10 \text{ lb}\cdot\text{ft}$ ).

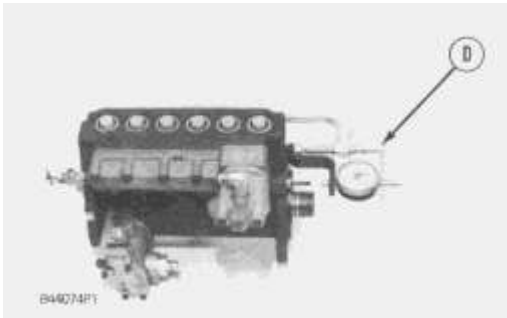

9. Install tooling (D) to measure total rack travel. Correct rack travel is **15.7 mm (.618 in.)**. A smaller measurement is an indication of wrong fuel injection pump installation.

10. Do Steps 1 through 9 again for installation of the other fuel pumps.

11. Install the cover and gasket on the fuel injection pump housing.

End By:

a. install governor \*

---

\*See Governor, Disassemble And Assemble

## Disassemble & Assemble Fuel Injection Pumps

Start By:

a. remove fuel injection pumps

---

### NOTICE

**Be careful when the injection pumps are disassembled. Do not damage the surfaces of the plungers, barrels and bonnets. Any scratches will cause leakage inside the fuel injection pump. The plunger and barrel for each pump are made as a set. Do not put the plunger of one pump in the barrel of another pump. If one part has wear, install a complete new pump assembly. Be careful when the plunger is put into the bore of the barrel.**

---

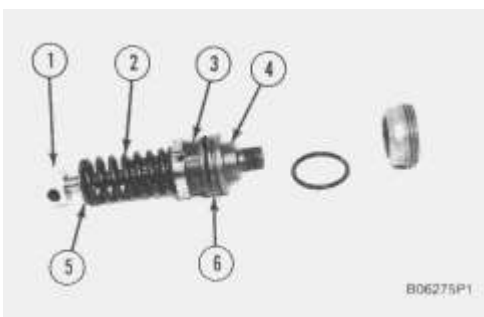

Thank you so much for reading.  
Please click the “Buy Now!”  
button below to download the  
complete manual.



After you pay.

You can download the most  
perfect and complete manual in  
the world immediately.

Our support email:

[ebooklibonline@outlook.com](mailto:ebooklibonline@outlook.com)