



Service Repair Manual

Models

259D COMPACT TRACK LOADER

Product: COMPACT TRACK LOADER
Model: 259D COMPACT TRACK LOADER GTK
Configuration: 259D Compact Track Loader GTK00001-UP (MACHINE)

Disassembly and Assembly C2.6 and C3.3B Engines for Caterpillar Built Machines

Media Number -UENR0137-11

Publication Date -01/08/2015

Date Updated -12/07/2018

i05242938

Pistons and Connecting Rods - Remove and Install

SMCS - 1225-010

Removal Procedure

Start By:

- a. Remove cylinder head.
- b. Remove engine oil pan.

Note: Refer to Specification UENR0995 "Engine Design" for non-specified engine Torque Values.

1. Rotate the crankshaft until the crank pin is at the bottom center position.

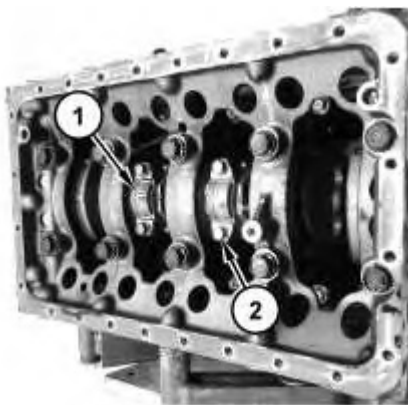

Illustration 1

g02797660

2. Remove bolts (2) and remove connecting rod cap (1).
-



Illustration 2

g02797658

3. Carefully push piston (3) and the connecting rod from cylinder block (4) bore.
4. The connecting rod and the connecting rod cap should have an etched Number (X) on the side. The number on the connecting rod and the connecting rod cap must match. Ensure that the connecting rod and the connecting rod cap are marked for the correct location. If necessary, make a temporary mark on the connecting rod and the connecting rod cap in order to identify the cylinder number.

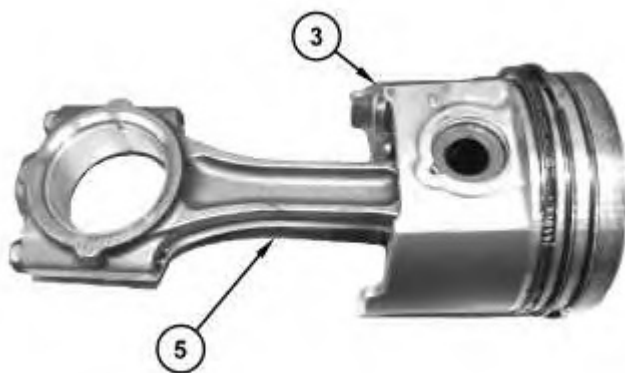

Illustration 3

g02797689

5. Remove piston (3) and connecting rod (5).

Installation Procedure

Table 1

Required Tools			
Tool	Part Number	Part Description	Qty
A	1U-6684	Piston Ring Compressor	1

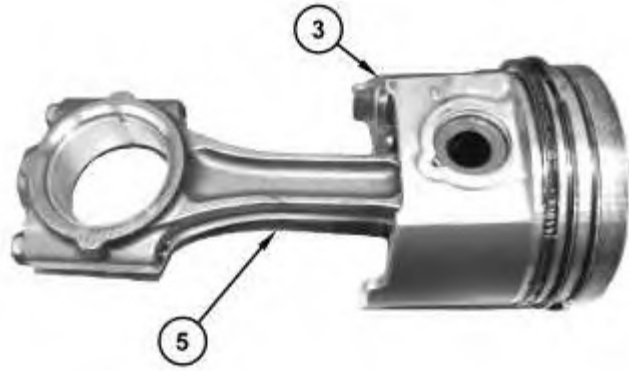

Illustration 4

g02797689

1. Inspect piston (3) and connecting rod assembly (5).
2. Apply clean engine oil to the cylinder bore, to the piston rings, to the outer surface of the piston and to the bearing shells.

Note: Install the bearing shells for the connecting rods dry when clearance checks are performed. Refer to Disassembly and Assembly, "Bearing Clearance - Check" for the correct procedure. Apply clean engine oil to the bearing shells for the connecting rods during final assembly.

Note: Ensure that the piston and the connecting rod assembly are installed in the correct cylinder.

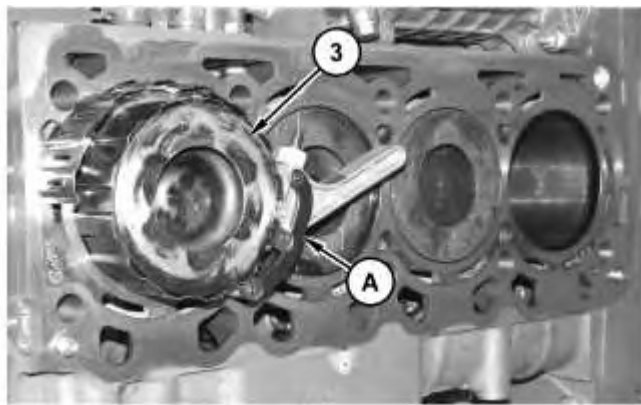

Illustration 5

g02797721

3. Install Tooling (A) onto piston (3).

Note: Ensure that Tooling (A) is installed correctly and that piston (3) can easily slide from the tool.

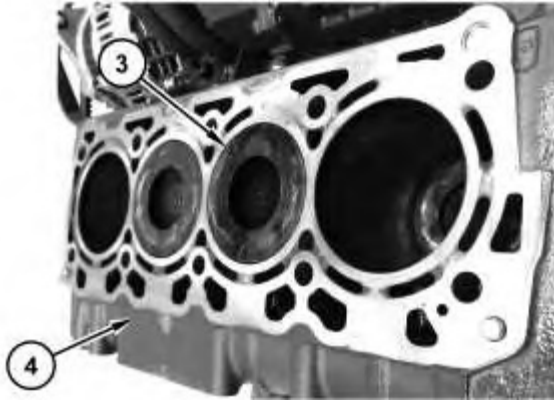

Illustration 6

g02797658

- Carefully push piston (3) and the connecting rod assembly into cylinder block (4) bore and onto the crankshaft pin.

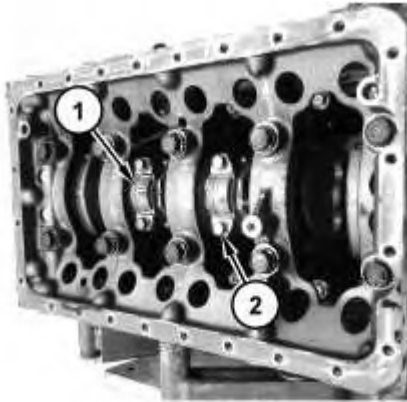

Illustration 7

g02797660

- Install connecting rod cap (1) onto the connecting rod .

Note: Ensure that etched Number (X) on connecting rod cap (1) matches etched Number (X) on the connecting rod. Ensure the correct orientation of the connecting rod cap. The locating tab for the upper bearing shell and the lower bearing shell should be on the same side.

Note: Do not reuse the old connecting rod bolts in order to secure the connecting rod cap.

- For the C3.3B apply clean engine oil to bolt threads and install new bolts (2) to the connecting rod. Tighten bolts (2) to a torque of 69 to 73 N·m (51 to 54 lb ft).
- For the C2.6 apply clean engine oil to bolt threads and install new bolts (2) to the connecting rod. Tighten bolts (2) to a torque of 45 ± 49 N·m (33 ± 36 lb ft).
- Ensure that the installed connecting rod assembly has side play. Rotate the crankshaft in order to ensure that there is no binding.
- Repeat Step 1 through Step 8 in order to install the remaining pistons and connecting rods.

End By:

Thank you so much for reading.
Please click the “Buy Now!”
button below to download the
complete manual.



After you pay.

You can download the most
perfect and complete manual in
the world immediately.

Our support email:

ebooklibonline@outlook.com