



Service Repair Manual

Models

307 MINI HYDRAULIC EXCAVATOR

S/N DAN00001 and up

Product: EXCAVATOR

Model: 307 EXCAVATOR 2WM

Configuration: 307 Excavator 2WM00500-UP (MACHINE) POWERED BY 3054 Engine

Disassembly and Assembly 3054 Engine for Caterpillar Built Machines

Media Number -SEN6241-13

Publication Date -01/08/2008

Date Updated -04/08/2008

i02105278

Fuel Injection Pump - Remove - Type 2 Engines and 7BJ Engines

SMCS - 1251-011

Removal Procedure

Table 1

Required Tools			
Tool	Part Number	Part Description	Qty
A	150-3992	Timing Pin ⁽¹⁾	1
	150-3993	Timing Pin ⁽²⁾	1
B	171-1085 or 173-9774	Tamper Resistant Tool Gp	1

⁽¹⁾ Tool (A) is required in order to remove Bosch fuel injection pumps.

⁽²⁾ Tool (A) is required in order to remove Delphi (Lucas) and Stanadyne fuel injection pumps.

Start By:

- A. Remove the water pump. Refer to Disassembly and Assembly, "Water Pump - Remove".
- B. Remove the fuel injection lines. Refer to Disassembly and Assembly, "Fuel Injection Lines - Remove and Install".

NOTICE

Keep all parts clean from contaminants.

Contaminants may cause rapid wear and shortened component life.

NOTICE

Care must be taken to ensure that fluids are contained during performance of inspection, maintenance, testing, adjusting and repair of the product. Be prepared to collect the fluid with suitable containers before opening any compartment or disassembling any component containing fluids.

Refer to Special Publication, NENG2500, "Caterpillar Tools and Shop Products Guide" for tools and supplies suitable to collect and contain fluids on Caterpillar products.

Dispose of all fluids according to local regulations and mandates.

1. Ensure that the No. 1 cylinder is at the top center position on the compression stroke. Refer to the Testing and Adjusting, "Fuel System" topic for additional information.
-

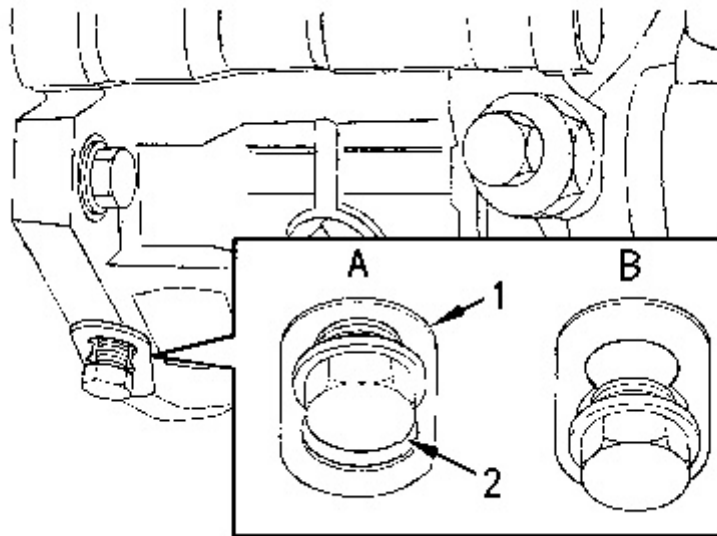

Illustration 1

g00808245

2. Loosen locking screw (2) (if equipped) until locking spacer (1) moves freely. Move locking spacer (1) into position (B). Tighten locking screw (2) to a torque of 10 N·m (7 lb ft).
-

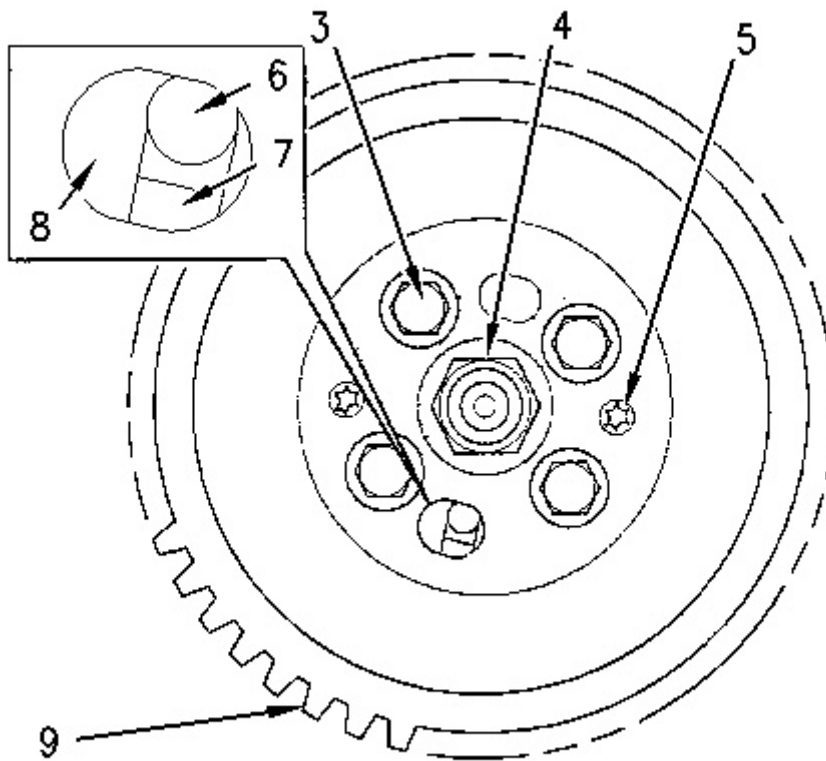

Illustration 2

g00808370

Typical example

Note: Do not remove hub nut (4) from the shaft of the fuel injection pump. The hub of the fuel injection pump is installed in the correct position from the factory in order to ensure proper timing. If hub nut (4) is removed and the hub is removed, the hub will need to be accurately installed on the shaft of the fuel injection pump by the use of special equipment. Refer to your Caterpillar Dealer for more information.

Note: Do not release Torx screws (5) (if equipped). If the Torx screws are released and the timing plate is moved, the timing position that is set at the factory will be lost. If the Torx screws are released, the No. 1 cylinder must be set to the top center position on the compression stroke before the Torx screws are tightened.

3. Slowly rotate the crankshaft until hole (6) in the timing gear and hole (7) in the hub are in alignment with hole (8) in the fuel injection pump body.

Note: The location of Tool (A) for Bosch fuel injection pumps will be located toward the top of the fuel injection pump. The location of Tool (A) for Delphi (Lucas) and Stanadyne fuel injection pumps will be located toward the bottom of the fuel injection pump.

4. Install Tool (A) through hole (6) in the timing gear and hole (7) in the hub. Push Tool (A) into position in hole (8) in the fuel injection pump body. If Tool (A) can be fully seated, the fuel injection pump timing is correct. No resistance should be felt when the timing pin is inserted into hole (8) of the fuel injection pump body.

Note: Some fuel injection pumps are installed with tamper proof bolts. Tool (B) may be necessary in order to remove the tamper proof bolts.

5. Remove four bolts (3) that fasten the fuel injection pump gear to the fuel injection pump. Timing gear (9) should be free from the fuel injection pump shaft.

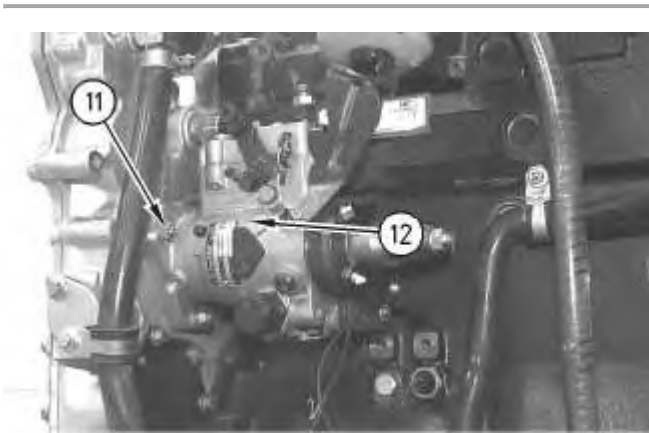

Illustration 3

g00808376

Typical example

6. Remove three flange nuts (10) and fuel injection pump (11) from the engine.

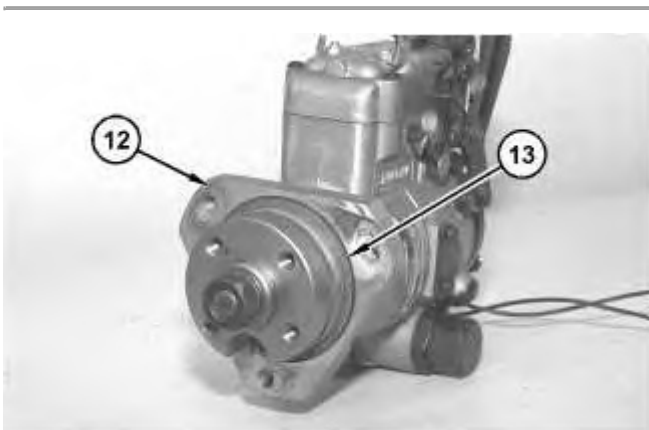

Illustration 4

g01059878

Typical example

7. Remove O-ring seal (12) from fuel injection pump (11) .

Thank you so much for reading.
Please click the “Buy Now!”
button below to download the
complete manual.



After you pay.

You can download the most
perfect and complete manual in
the world immediately.

Our support email:

ebooklibonline@outlook.com