



Service Repair Manual

Models

320D and 320D L Excavator

Product: EXCAVATOR

Model: 320D EXCAVATOR MZD

Configuration: 320D & 320D L Excavators MZD00001-UP (MACHINE) POWERED BY C6.6 Engine

Disassembly and Assembly C6.6 Engines for Caterpillar Built Machines

Media Number -KENR6081-15

Publication Date -01/03/2014

Date Updated -04/03/2014

i03547100

Rocker Shaft and Pushrod - Install

SMCS - 1102-012; 1208-012

Installation Procedure

Table 1

Required Tools			
Tool	Part Number	Part Description	Qty
A	227-4389	E10 Torx Socket	1
B	385-4005	Feeler Gauge	1

NOTICE

Keep all parts clean from contaminants.

Contaminants may cause rapid wear and shortened component life.

1. Clean the valve bridges. Inspect the valve bridges for wear or damage. Replace any valve bridges that are worn or damaged.
-

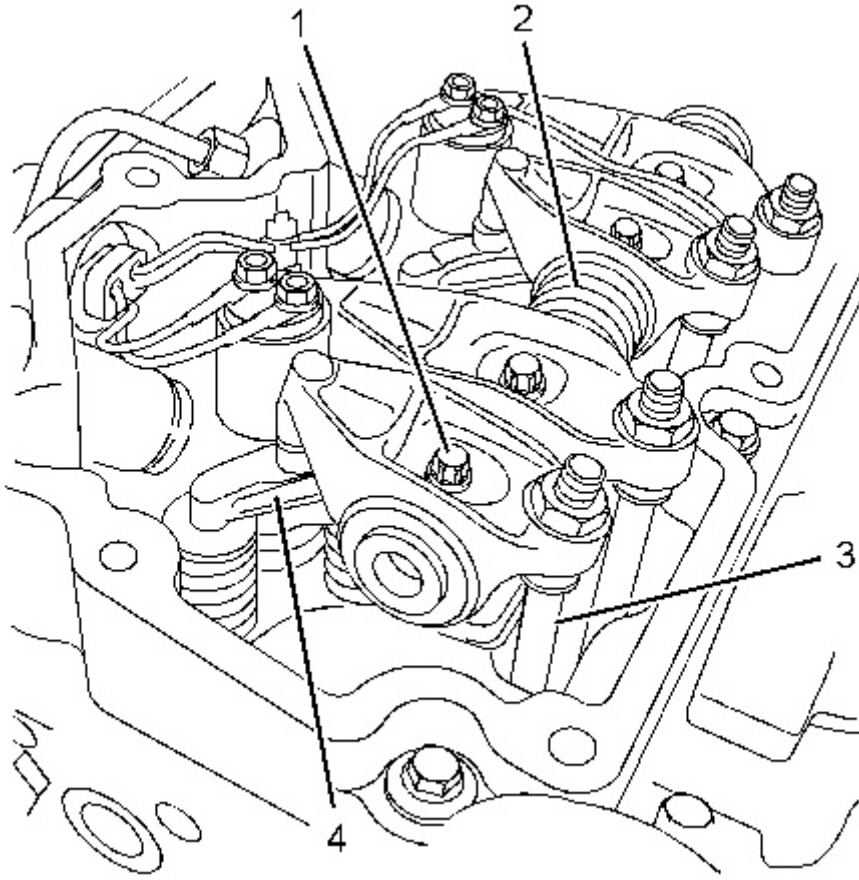

Illustration 1

g01340041

2. Lubricate valve bridges (4) with clean engine oil.
-

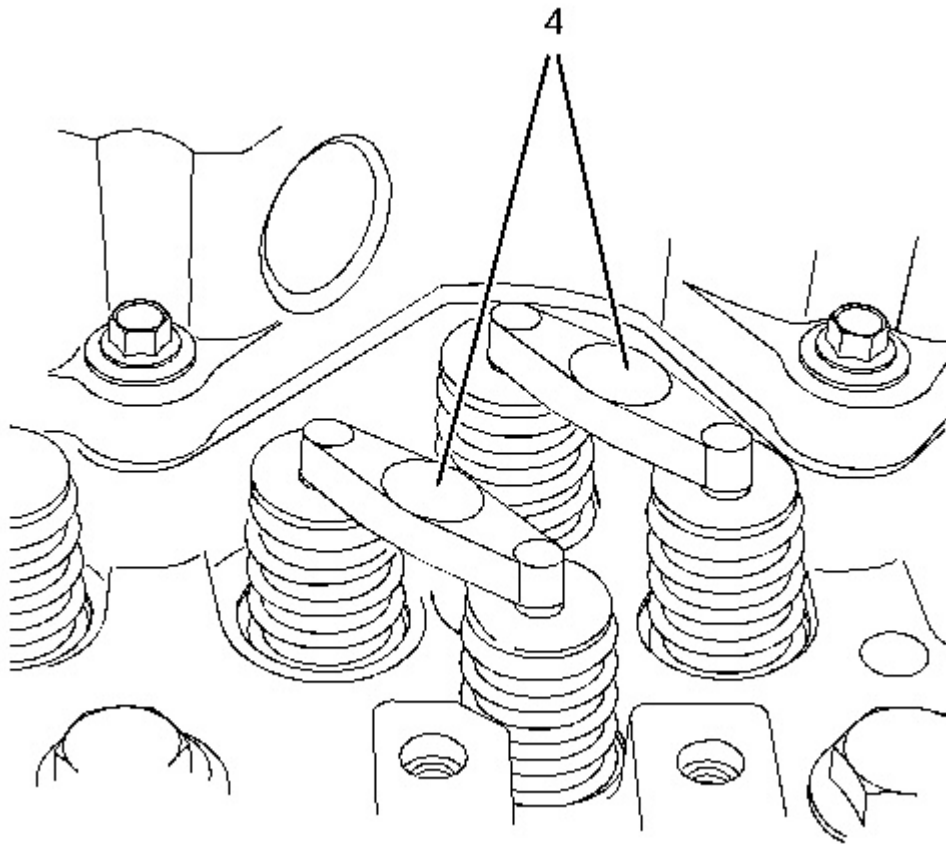

Illustration 2

g01355120

The correct location of valve bridges on valve stems is shown. The electronic unit injector is not shown for clarity.

NOTICE

Failure to ensure that ALL valve bridges are correctly seated onto the valve stems will cause interference between the pistons and the valves, resulting in damage to the engine.

3. Install valve bridges (4) to the cylinder head.

Note: Install used valve bridges in the original location and in the original orientation. Ensure that the valve bridges are correctly seated on the valves. New valve bridges may be installed in either orientation.

4. Clean the pushrods. Inspect the pushrods for wear or damage. Replace any pushrods that are worn or damaged.
5. Apply clean engine lubricating oil to both ends of pushrods (3). Install the pushrods to the engine with the cup upward.

Note: Ensure that pushrods (3) are installed in the original location and that the ball end of each pushrod is correctly seated in the valve lifters.

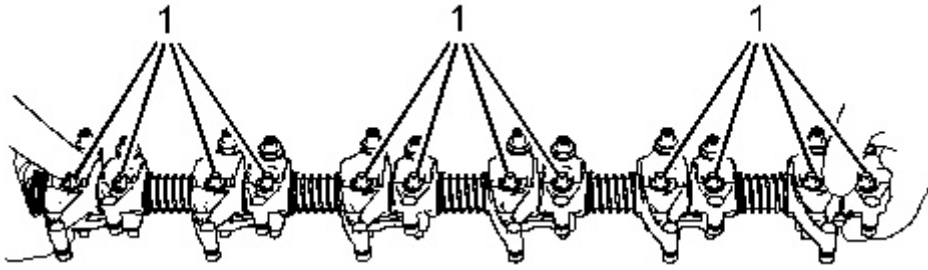

Illustration 3

g01340040

6. Ensure that the rocker shaft assembly is clean and free from wear or damage. Install torx screws (1) in the rocker shaft.

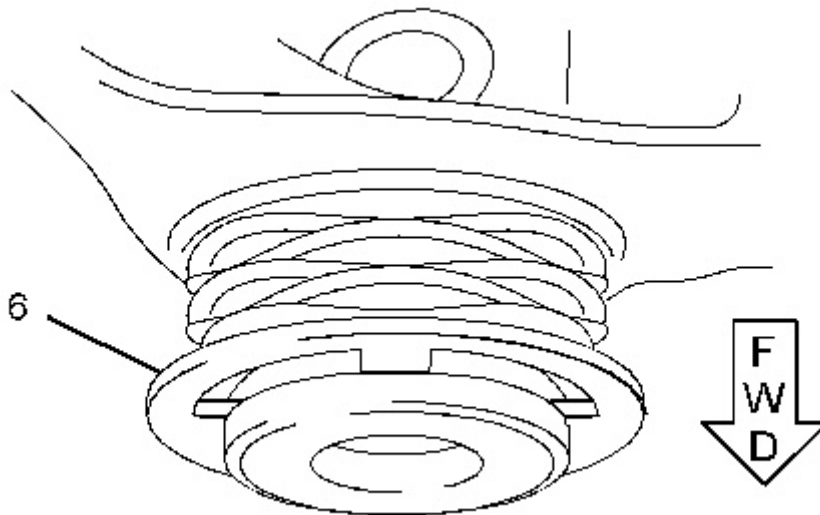

Illustration 4

g01340044

7. Position rocker shaft assembly (2) onto the cylinder head. The retaining clip (6) should face the front of the engine.

Note: Ensure that adjustment screws (5) are properly seated in ends of pushrods (3).

8. Use Tooling (A) to gradually tighten torx screws (1).

Note: To avoid distortion of rocker shaft assembly (2), tighten the torx screws in the center first. Work toward the outside of the rocker shaft assembly.

Tighten torx screws (1) to a torque of 35 N·m (26 lb ft).

Thank you so much for reading.
Please click the “Buy Now!”
button below to download the
complete manual.



After you pay.

You can download the most
perfect and complete manual in
the world immediately.

Our support email:

ebooklibonline@outlook.com