



Service Repair Manual

Models

320D2 Excavator

Product: EXCAVATOR

Model: 320D2 EXCAVATOR WBY

Configuration: 320D2 Excavator WBY00001-UP (MACHINE) POWERED BY C7.1 Engine

Disassembly and Assembly C7.1 (Mech) Engines for Caterpillar Built Machines

Media Number -UENR0674-08

Publication Date -01/06/2015

Date Updated -23/01/2017

i06257875

Fuel Injection Pump - Remove - With Boost Control

SMCS - 1251-011

Removal Procedure

Table 1

Required Tools			
Tool	Part Number	Part Description	Qty
A ⁽¹⁾	9U-7336	Crankshaft Turning Tool	1
A ⁽²⁾	5P-7305	Housing	1
	5P-7305	Engine Turning Tool	1
B	136-4632	Timing Pin (Crankshaft)	1
	268-1966	Adapter	1
C	230-6284	Timing Pin (Camshaft)	1
D	422-7170	Capping Kit	1

⁽¹⁾ The Crankshaft Turning Tool is used on the front pulley.

⁽²⁾ This Tool is used in the aperture for the electric starting motor.

Start By:

- A. Remove the front cover. Refer to Disassembly and Assembly, "Front Cover - Remove and Install" for the correct procedure .
- B. Remove the fuel injection lines. Refer to Disassembly and Assembly, "Fuel Injection Lines - Remove" for the correct procedure.

Note: Either Tooling (A) can be used. Use the Tooling that is most suitable.



WARNING

Contact with high pressure fuel may cause fluid penetration and burn hazards. High pressure fuel spray may cause a fire hazard. Failure to follow these inspection, maintenance and service instructions may cause personal injury or death.

NOTICE

Ensure that all adjustments and repairs that are carried out to the fuel system are performed by authorized personnel that have the correct training.

Before beginning ANY work on the fuel system, refer to Operation and Maintenance Manual, "General Hazard Information and High Pressure Fuel Lines" for safety information.

Refer to System Operation, Testing and Adjusting, "Cleanliness of Fuel System Components" for detailed information on the standards of cleanliness that must be observed during ALL work on the fuel system.

1. Turn the fuel supply to the OFF position.
 2. Turn the battery disconnect switch to the OFF position.
-

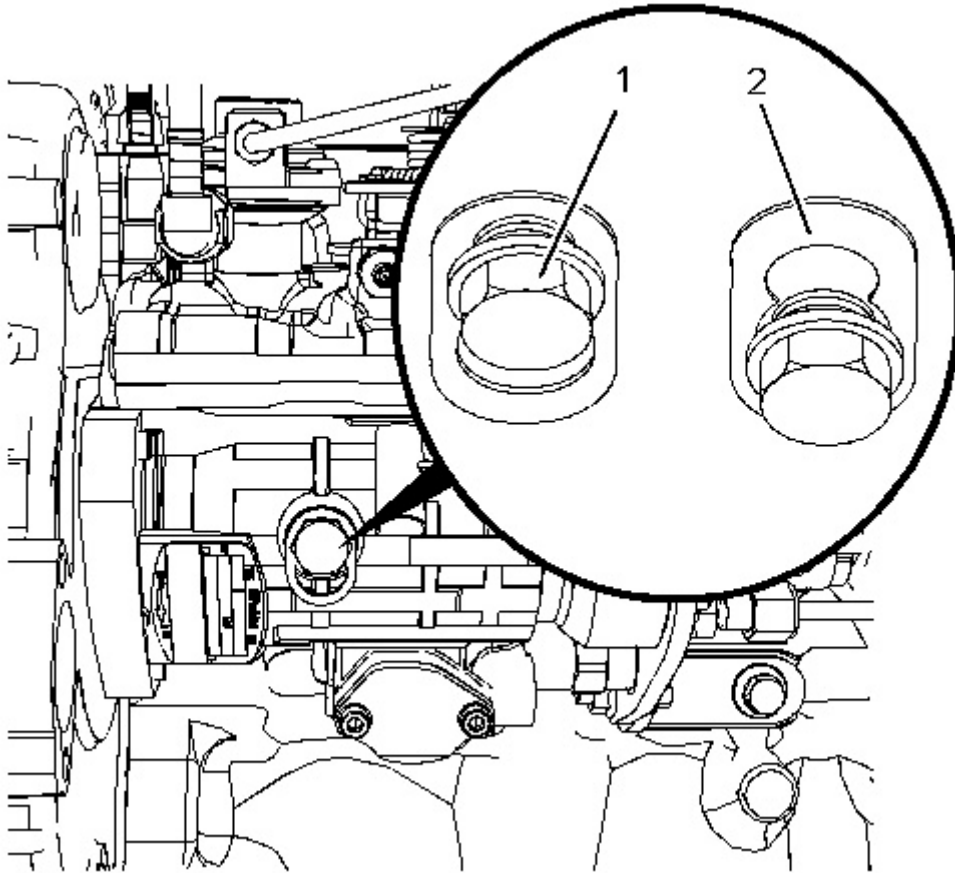

Illustration 1

g02791601

3. Use Tooling (A) in order to rotate the crankshaft so that number one piston is at top dead center position . Refer to System Operation, Testing and Adjusting, "Finding Top Center Position for No.1 Piston" for the correct procedure.
4. Use Tooling (B) in order to lock the crankshaft so that number one piston is at top dead center position.
5. Use Tooling (C) in order to lock the camshaft.
6. Loosen locking screw (1) . Rotate spacer (2) in order to allow locking screw (1) to tighten against the shaft of the fuel injection pump. Rotate the fuel injection pump gear in a counterclockwise direction in order to remove the backlash. Tighten locking screw (1) to a torque of 15 N·m (133 lb in).

Note: Locking the screw must be tightened in order to prevent the shaft of the fuel injection pump from rotating. The shaft of the fuel injection pump must not be rotated after the fuel injection pump has been removed from the engine.

7. Remove the backlash from the fuel pump gear. Lock the fuel injection pump in the correct position and remove the fuel pump gear. Refer to Disassembly and Assembly, "Fuel Pump Gear - Remove and Install" for the correct procedure.
-

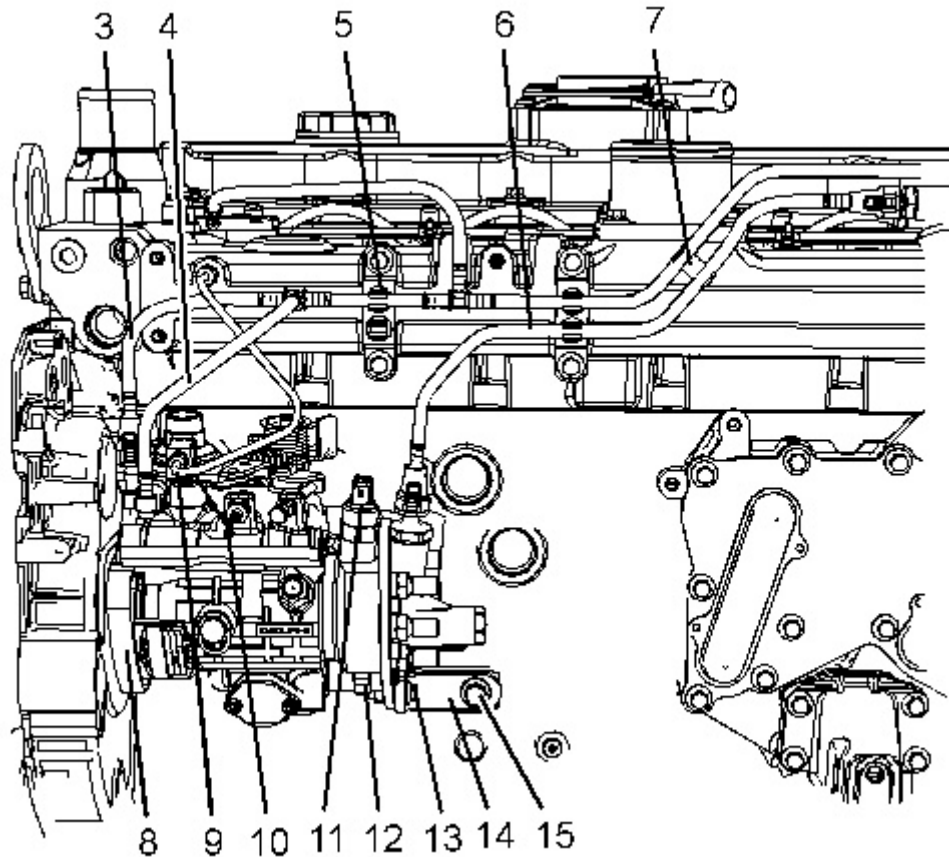

Illustration 2

g02791603

8. Clean fuel injection pump (8) and the area around the fuel injection pump. Ensure that the area is free from contamination before beginning disassembly.
9. Place a suitable container below fuel injection pump (8) in order to catch any fuel that might be spilled.
10. Disconnect plastic tube assembly (3) , plastic tube assembly (4) , and plastic tube assembly (6) from fuel injection pump (8) .
11. Remove plastic tube assembly (3) , plastic tube assembly (4) , and plastic tube assembly (6) from clips (5) and clip (7) . Position the plastic tube assemblies away from the fuel injection pump.
12. Use Tooling (D) in order to plug plastic tube assembly (3) , plastic tube assembly (4) , and plastic tube assembly (6) .
13. Use Tooling (D) in order to cap connections for the plastic tube assemblies on fuel injection pump (8) .
14. Remove tube assembly (9) from fuel injection pump (8) and the cylinder head.
15. Remove seal (10) (not shown).
16. Disconnect the OEM harness assemblies from solenoid (11) and solenoid (12) .
17. Remove the nut and bolt (13) from fuel injection pump (8) .

Thank you so much for reading.
Please click the “Buy Now!”
button below to download the
complete manual.



After you pay.

You can download the most
perfect and complete manual in
the world immediately.

Our support email:

ebooklibonline@outlook.com