



Service Repair Manual

Models

320D2 and 320D2 L Excavator

Product: EXCAVATOR

Model: 320D2 L EXCAVATOR WBF

Configuration: 320D2 & 320D2 L Excavators WBF00001-UP (MACHINE) POWERED BY C7.1 Engine

Disassembly and Assembly C7.1 (Mech) Engines for Caterpillar Built Machines

Media Number -UENR0674-08

Publication Date -01/06/2015

Date Updated -23/01/2017

i04780443

Flywheel - Remove

SMCS - 1156-011

Removal Procedure

Table 1

Required Tools			
Tool	Part Number	Part Description	Qty
A	-	Guide Stud 1/2 inch - UNF by 4 inch	2

Start By:

- Remove the electric starting motor. Refer to Disassembly and Assembly, "Electric Starting Motor - Remove and Install" for the correct procedure.

NOTICE

Keep all parts clean from contaminants.

Contaminants may cause rapid wear and shortened component life.

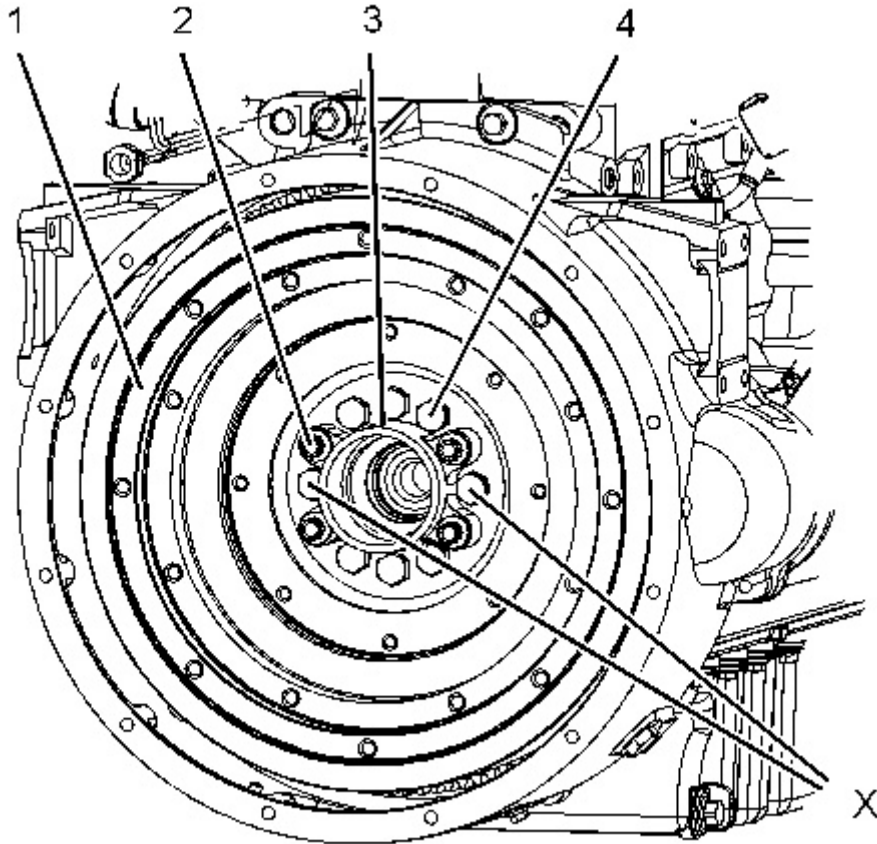

Illustration 1
Typical example

g01336668

1. Remove bolts from Position (X) from flywheel (1).
 2. Install Tooling (A) in Position (X) to flywheel (1).
 3. Install a suitable lifting device onto flywheel (1). Support the weight of the flywheel. The flywheel can weigh 71 kg (156 lb).
 4. If necessary, remove bolts (2) that secure the housing for pilot bearing (3) to flywheel (1). Remove the housing for pilot bearing (3).
 5. Remove remaining bolts (4).
 6. Use the lifting device to remove the flywheel from the engine.
-

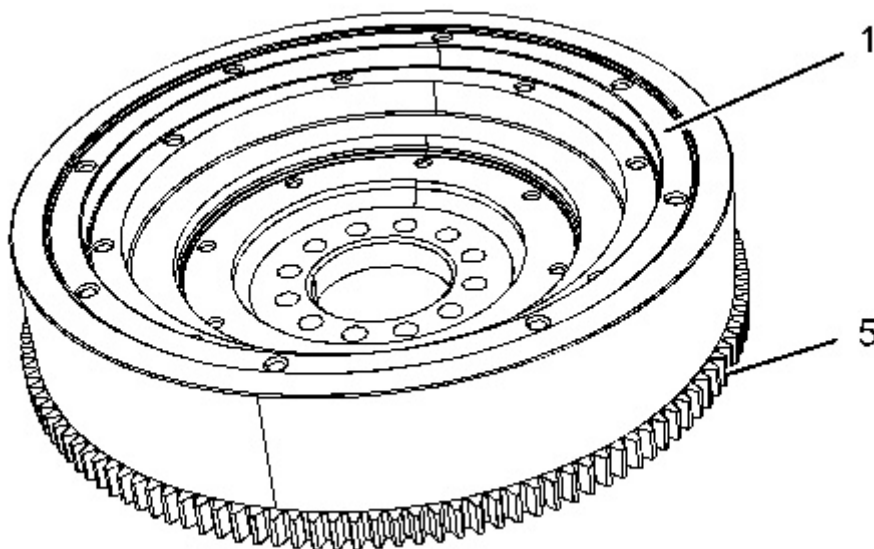

Illustration 2

g01336669

Typical example

7. Inspect flywheel (1) and ring gear (5) for wear and damage. Replace any worn components or damaged components.
8. To remove flywheel ring gear (5), follow Step 8.a through Step 8.b.
 - a. Place the flywheel assembly on a suitable support.
 - b. Use a hammer and a punch in order to remove ring gear (5) from flywheel (1).

Note: Identify the orientation of the teeth on the flywheel ring gear.

Product: EXCAVATOR

Model: 320D2 L EXCAVATOR WBF

Configuration: 320D2 & 320D2 L Excavators WBF00001-UP (MACHINE) POWERED BY C7.1 Engine

Disassembly and Assembly C7.1 (Mech) Engines for Caterpillar Built Machines

Media Number -UENR0674-08

Publication Date -01/06/2015

Date Updated -23/01/2017

i04780442

Flywheel - Install

SMCS - 1156-012

Installation Procedure

Table 1

Required Tools			
Tool	Part Number	Part Description	Qty
A	-	Guide Stud 1/2 inch - UNF by 4 inch	2

NOTICE

Keep all parts clean from contaminants.

Contaminants may cause rapid wear and shortened component life.

Thank you so much for reading.
Please click the “Buy Now!”
button below to download the
complete manual.



After you pay.

You can download the most
perfect and complete manual in
the world immediately.

Our support email:

ebooklibonline@outlook.com