



Service Repair Manual

Models

320E L Excavator

Product: EXCAVATOR

Model: 320E L EXCAVATOR REE

Configuration: 320E L EXCAVATORS REE00001-UP (MACHINE) POWERED BY C6.6 Engine

Disassembly and Assembly C6.6 Engines for Caterpillar Built Machines

Media Number -KENR9249-07

Publication Date -01/09/2015

Date Updated -19/06/2017

i03914529

Gear Group (Front) - Remove and Install

SMCS - 1206-010

Removal Procedure

Table 1

Required Tools			
Tool	Part Number	Part Description	Qty
A ⁽¹⁾	9U-6198	Crankshaft Turning Tool	1
A ⁽²⁾	5P-7306	Housing	1
	5P-7305	Engine Turning Tool	1
B	230-6284	Timing Pin (Camshaft)	1
C	364-9107	Fuel Injection Pump Timing Pin	1
D	136-4632	Timing Pin (Crankshaft)	1
E	-	T40 Torx Socket	1

⁽¹⁾ The Crankshaft Turning Tool is used on the front pulley.

⁽²⁾ This Tool is used in the aperture for the electric starting motor.

Start By:

- Remove the front cover. Refer to Disassembly and Assembly, "Front Cover - Remove and Install" for the correct procedure.
- Remove the valve mechanism cover. Refer to Disassembly and Assembly, "Valve Mechanism Cover - Remove and Install" for the correct procedure.

NOTICE

Keep all parts clean from contaminants.

Contaminants may cause rapid wear and shortened component life.

NOTICE

Care must be taken to ensure that fluids are contained during performance of inspection, maintenance, testing, adjusting and repair of the product. Be prepared to collect the fluid with suitable containers before opening any compartment or disassembling any component containing fluids.

Dispose of all fluids according to local regulations and mandates.

Note: Either Tooling (A) can be used. Use the Tooling that is most suitable. Care must be taken in order to ensure that the fuel injection pump timing is not lost during the removal of the front gear group. Carefully follow the procedure in order to remove the gear group.

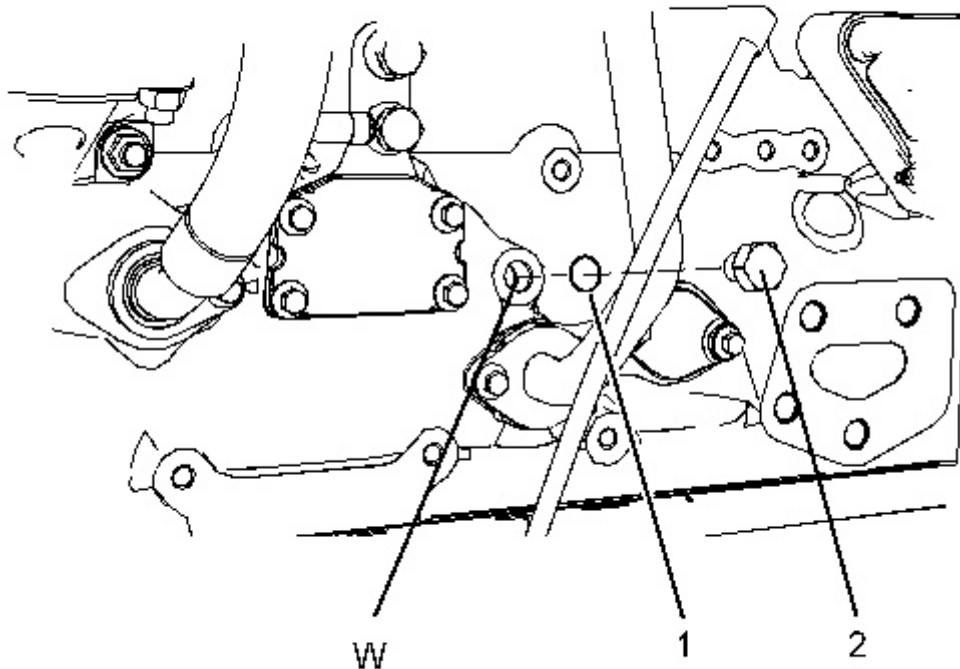

1. Remove plug (2) from the cylinder block. Remove O-ring seal (1) from the plug.
 2. Use Tooling (A) in order to rotate the crankshaft so that number one piston is at top dead center on the compression stroke. Refer to System Operation, Testing and Adjusting, "Finding Top Center Position for No.1 Piston" for the correct procedure.
 3. Install Tooling (D) through Hole (W) in order to lock the crankshaft.
 4. Remove Tooling (D).
 5. Use Tooling (A) in order to rotate the crankshaft in a clockwise direction and position the crankshaft at 60 degrees after top dead center. Refer to System Operation, Testing and Adjusting, "Position the Valve Mechanism Before Maintenance Procedures" for the correct procedure.
-

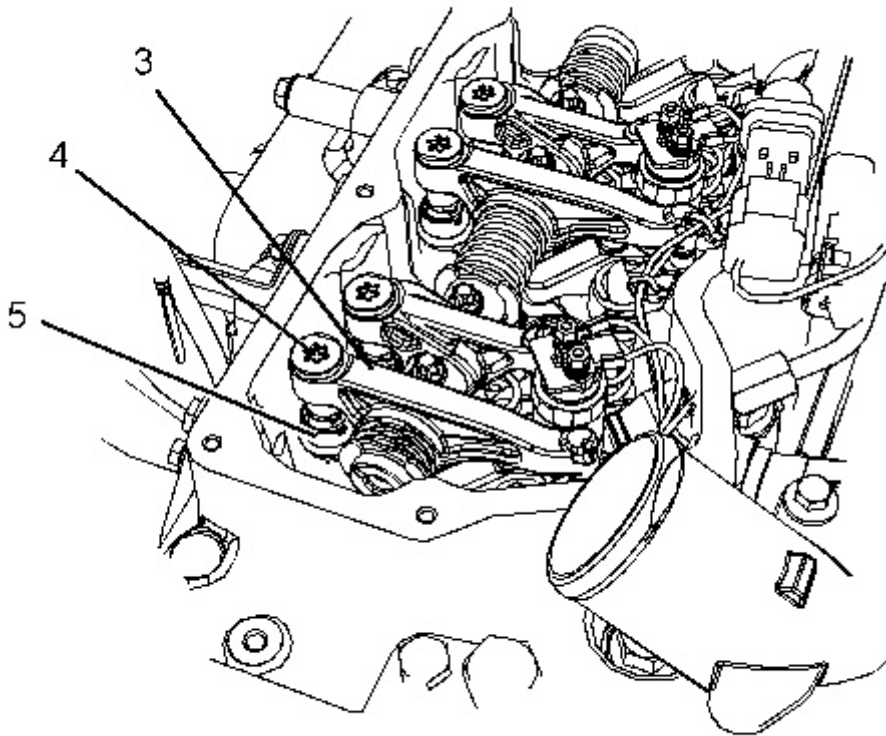

Illustration 2

g01992077

6. Use Tooling (E) in order to loosen threaded inserts (4) on all rocker arms (3). Unscrew threaded inserts (4) on all rocker arms (3) until all valves are fully closed. Ensure that guides (5) for the pushrods are left in position on threaded inserts (4).

Note: Ensure that ALL threaded inserts are fully unscrewed.

7. Use Tooling (A) in order to rotate the crankshaft so that number one piston is at top dead center on the compression stroke. Refer to System Operation, Testing and Adjusting, "Finding Top Center Position for No.1 Piston" for the correct procedure.

8. Use Tooling (C) in order to lock the fuel injection pump gear in the correct position. Refer to Disassembly and Assembly, "Fuel Injection Pump - Remove" for the correct procedure.
-

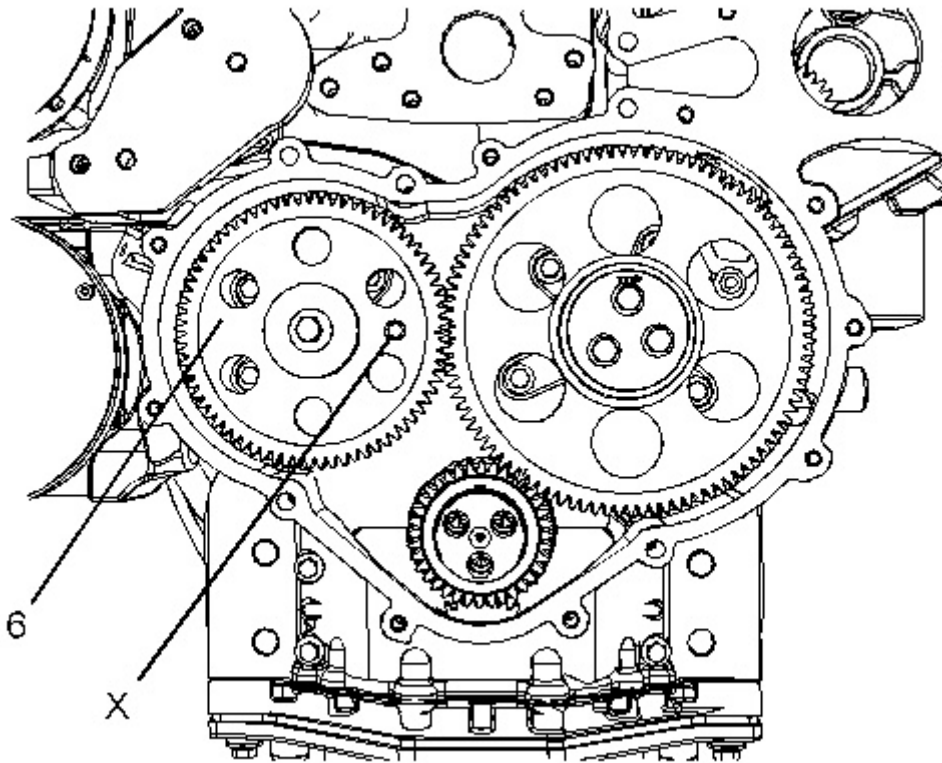

Illustration 3

g01992075

9. Install Tooling (B) through Hole (X) in camshaft gear (6) into the front housing. Use Tooling (B) in order to lock the camshaft in the correct position. Refer to System Operation, Testing and Adjusting, "Finding Top Center Position for No.1 Piston" for the correct procedure.
10. Install Tooling (D) into Hole (W) in the cylinder block. Use Tooling (D) in order to lock the crankshaft in the correct position. Refer to System Operation, Testing and Adjusting, "Finding Top Center Position for No.1 Piston" for the correct procedure.

Note: Do not use excessive force to install Tooling (D). Do not use Tooling (D) to hold the crankshaft during repairs.

Thank you so much for reading.
Please click the “Buy Now!”
button below to download the
complete manual.



After you pay.

You can download the most
perfect and complete manual in
the world immediately.

Our support email:

ebooklibonline@outlook.com