



# Service Repair Manual

## **Models**

# 322C FM EXCAVATOR

---

Product: EXCAVATOR

Model: 322C FM EXCAVATOR C3R

Configuration: 322C Forest Swing Machines C3R00001-UP (MACHINE) POWERED BY 3126B Engine

## Disassembly and Assembly 3126B Engines for Caterpillar Built Machines

Media Number -SEN9581-06

Publication Date -01/08/2018

Date Updated -17/08/2018

i01908258

# Unit Injector Hydraulic Pump - Remove

SMCS - 1714-011

## Removal Procedure

Table 1

Required Tools			
Tool	Part Number	Part Description	Qty
A	5P-0327	Crowfoot Wrench	1
B	180-0186	Removal Tool	1

---

### NOTICE

**Keep all parts clean from contaminants.**

**Contaminants may cause rapid wear and shortened component life.**

---

### NOTICE

**Care must be taken to ensure that fluids are contained during performance of inspection, maintenance, testing, adjusting, and repair of the product. Be prepared to collect the fluid with suitable containers before opening any compartment or disassembling any component containing fluids.**

Refer to Special Publication, NENG2500, "Dealer Service Tool Catalog" for tools and supplies suitable to collect and contain fluids on Cat products.

Dispose of all fluids according to local regulations and mandates.

---

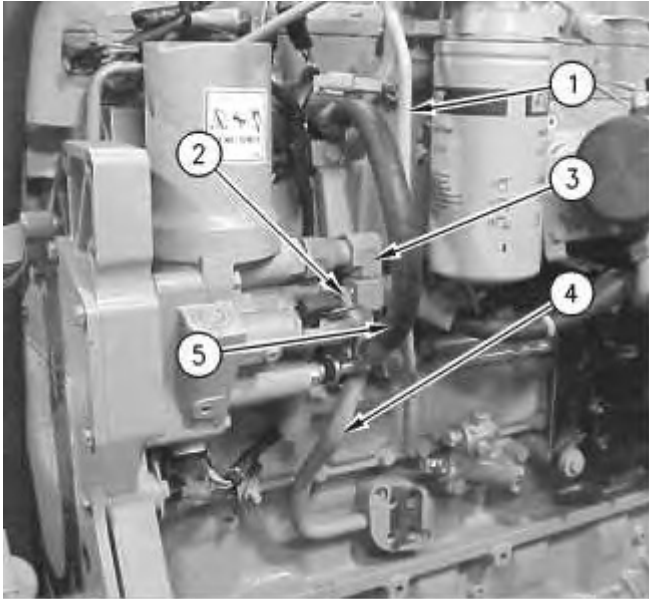

Illustration 1

g00727629

---

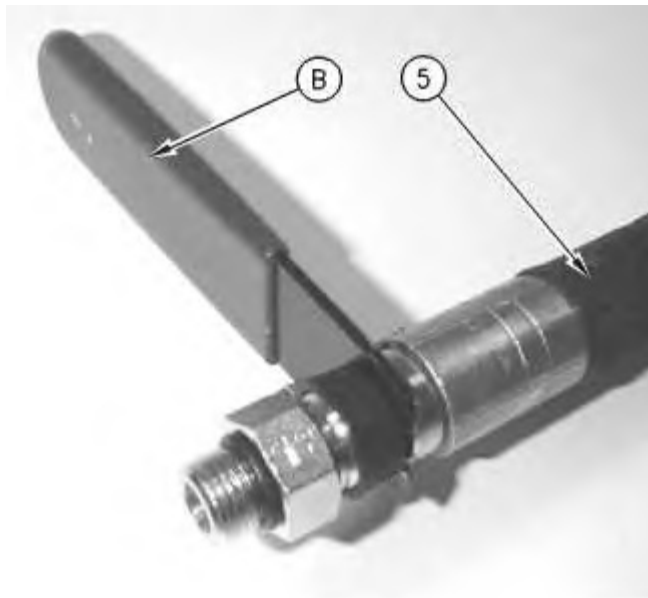

Illustration 2

g00774887

Hose assembly (5) is disconnected in Illustration 2 for photographic purposes.

1. Insert Tooling (B) on the hose side of the rubber boot on hose assembly (5). Push the rubber boot toward the fitting in order to remove hose assembly (5). Use Tooling (A) to remove line assembly (1).

**Note:** If Tooling (B) is not available, screwdrivers that are medium sized may be used. Insert the screwdrivers on each side of the rubber boot and move the rubber boot toward the fitting. This will allow the removal of hose assembly (5).

2. Disconnect harness assembly (2).
3. Remove return line assembly (4) from the engine block and from fitting (3).

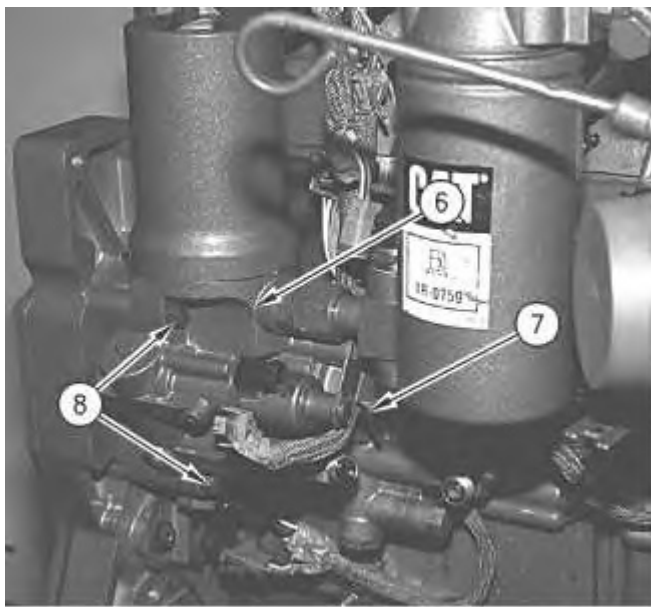

Illustration 3

g00727632

4. Cut cable strap (7) that fastens the harness assembly to unit injector hydraulic pump (6).
5. Remove three bolts (8) and remove unit injector hydraulic pump (6) from the timing gear housing.

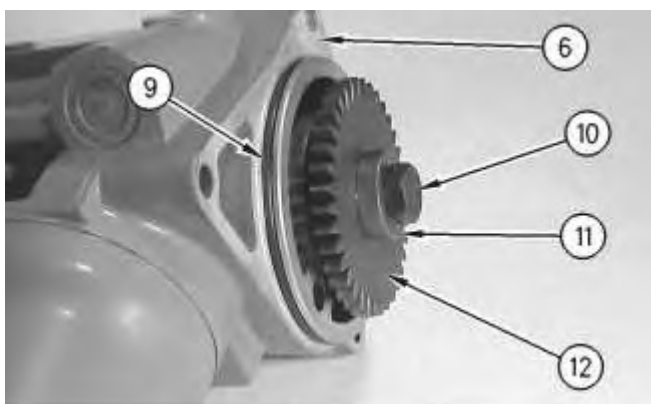

Illustration 4

g00994656

6. Remove O-ring seal (9) from unit injector hydraulic pump (6). Inspect the O-ring seal for wear or for damage. If the O-ring seal is worn or damaged, use a new part for replacement.
7. Remove bolt (10) and washer (11). Remove drive gear (12). Inspect the drive gear for wear or for damage. Replace the drive gear, if necessary.

Thank you so much for reading.  
Please click the “Buy Now!”  
button below to download the  
complete manual.



After you pay.

You can download the most  
perfect and complete manual in  
the world immediately.

Our support email:

[ebooklibonline@outlook.com](mailto:ebooklibonline@outlook.com)