



Service Repair Manual

Models

329DL EXCAVATOR

S/N -

S/N -

S/N -

S/N -

Assembly Procedure

Table 1

Required Tools			
Tool	Part Number	Part Description	Qty
B	1P-2420	Transmission Repair Stand	1
C	138-7575	Link Bracket	3
D	1P-0510	Driver Group	1
	1U-8605	Seal Guide	1
E	1P-1859	Retaining Ring Pliers	1
H	1U-6396	O-Ring Assembly Compound	1

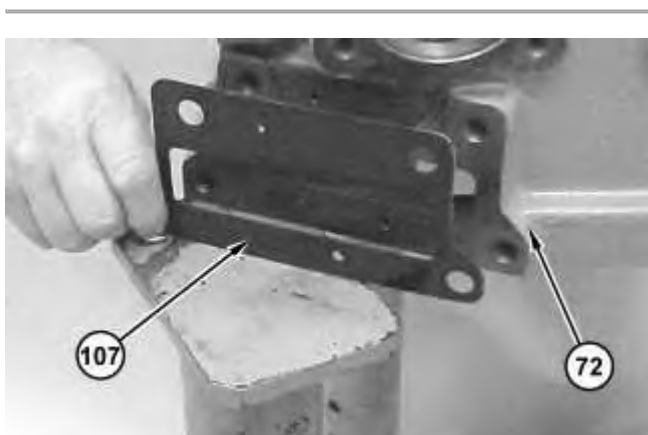

Illustration 1

g01200516

1. Install gasket (107) onto pump housing (72) .

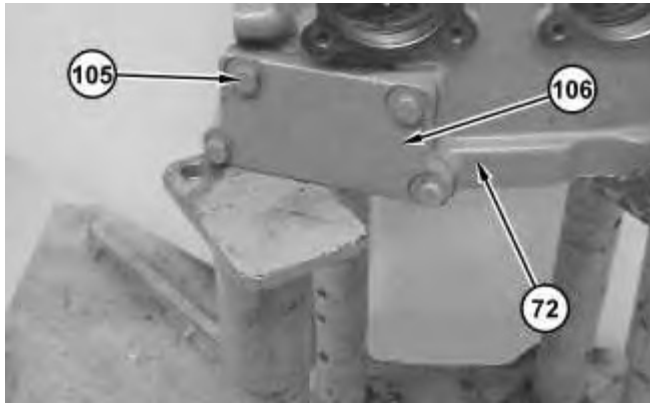

Illustration 2

g01200514

2. Install cover (106) and bolts (105) onto pump housing (72) .

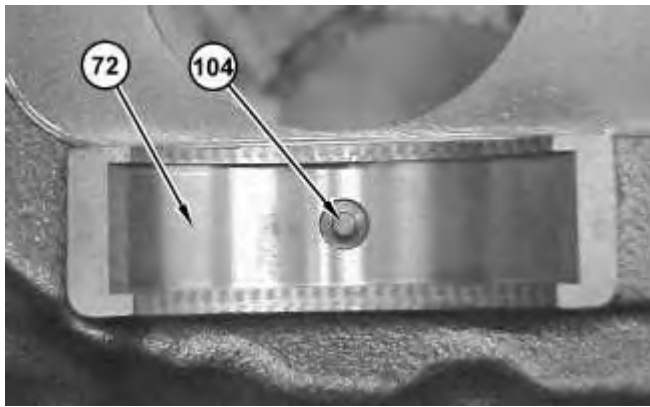

Illustration 3

g01200512

3. Install guide pins (104) onto pump housing (72) .

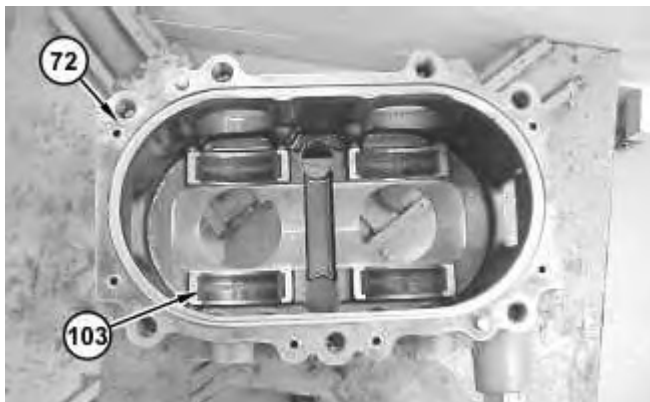

Illustration 4

g01200511

4. Install bearings (103) onto pump housing (72) .

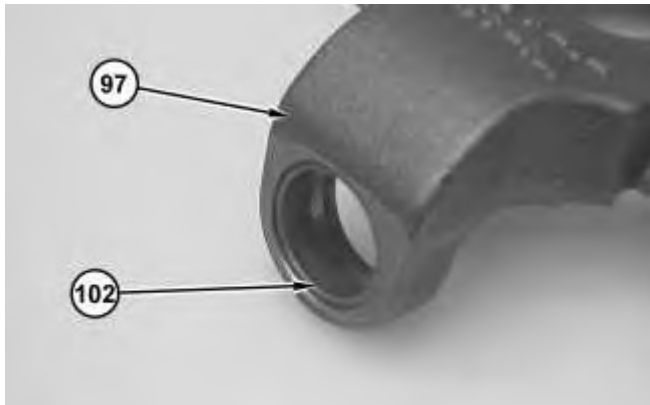

Illustration 5

g01200510

5. Install bearing (102) into swashplate (97) .



Illustration 6

g01200509

6. Install dowel pins (101) into swashplate (97) .



7. Install bearings (100) onto swashplate assembly (97) .



Illustration 8

8. Install plate (99) onto swashplate assembly (97) .
9. Repeat Step 5 through Step 8 for swashplate assembly (98) .

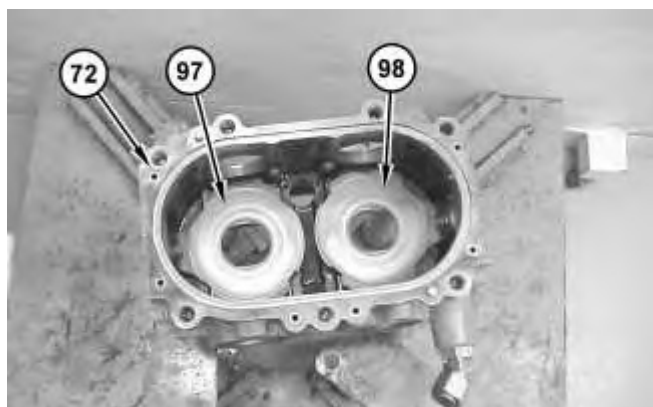

Illustration 9

10. Install swashplate assemblies (97) and (98) into pump housing (72) .

Note: The swashplate assemblies must be installed in the original position during assembly.

Thank you so much for reading.
Please click the “Buy Now!”
button below to download the
complete manual.



After you pay.

You can download the most
perfect and complete manual in
the world immediately.

Our support email:

ebooklibonline@outlook.com