



Service Repair Manual

Models

329DL MOBILE HYD
POWER UNIT Excavator

Tool	Part Number	Part Description	Qty
A	1P-2420	Transmission Repair Stand	1
B	138-7573	Link Bracket	2
C	1P-1863	Retaining Ring Pliers	1
D	138-7575	Link Bracket	3
E	4C-8359	Eyebolt	2
F	138-7574	Link Bracket	2
G	138-7576	Link Bracket	2

Start By:

- a. Start by removing the final drive. Refer to Disassembly and Assembly, "Final Drive - Remove".

Note: Cleanliness is an important factor. Before the disassembly procedure, the exterior of the component should be thoroughly cleaned. This will prevent dirt from entering the internal mechanism.

1. Put an alignment mark across the sections of the final drive for assembly purposes. The parts must be reinstalled to the original locations.



Illustration 1

g00892878

2. Use Tooling (G) and a suitable lifting device to position the final drive assembly onto Tooling (A). The weight of the final drive assembly is approximately 550 kg (1200 lb).
3. Remove bolts (1).

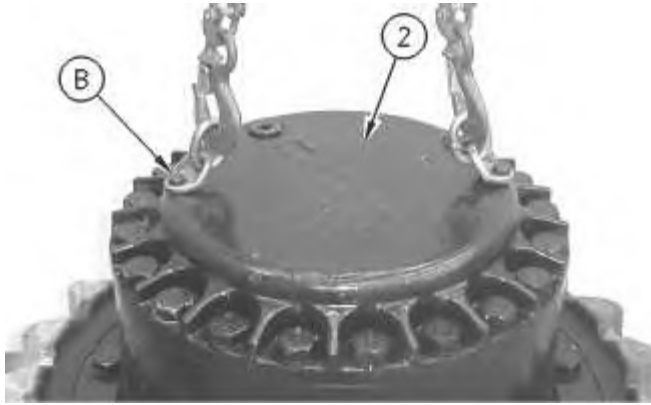

Illustration 2

g00892883

4. Use Tooling (B) and a suitable lifting device to remove cover (2). The weight of cover (2) is approximately 32 kg (70 lb).



Illustration 3

g00892888

5. Remove bolts (3) and gear (4). Check plate (6). Replace plate (6) if plate (6) is worn. Remove plugs (5) from cover (2).



Illustration 4

g00892906

6. Remove O-ring seals (7) from plugs (5).

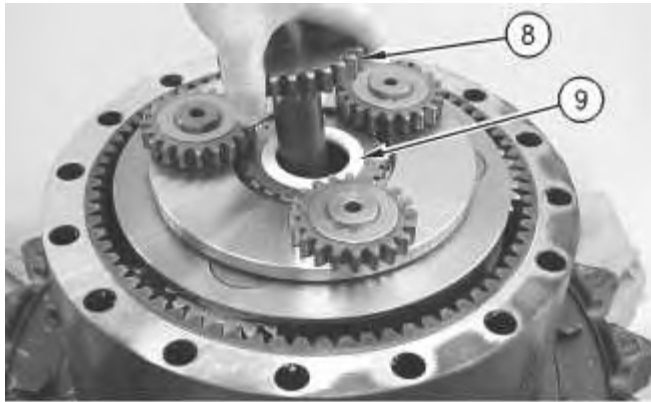

Illustration 5

g00892930

7. Remove gear (8) and spacer (9).



Illustration 6

g00892965

8. Use Tooling (C) to remove retaining ring (10). Remove washer (11) and gear (12). Remove bearing assembly (13) and washer (14).
9. Repeat Step 8 for the other two gear assemblies.

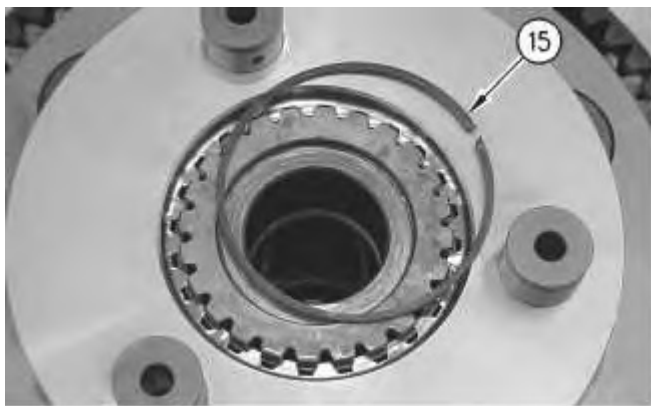

Illustration 7

g00892968

10. Remove retaining ring (15).

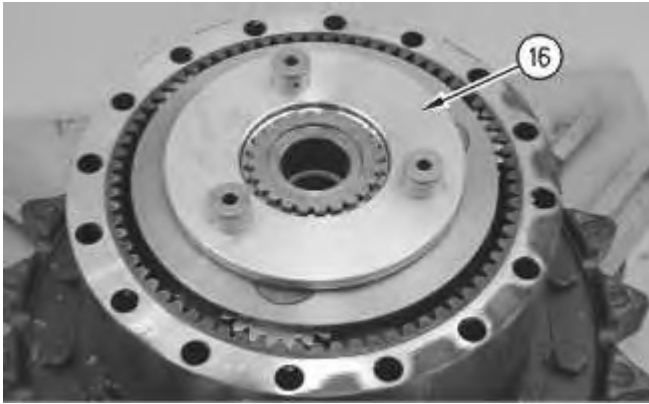

Illustration 8

g00892975

11. Remove carrier assembly (16).

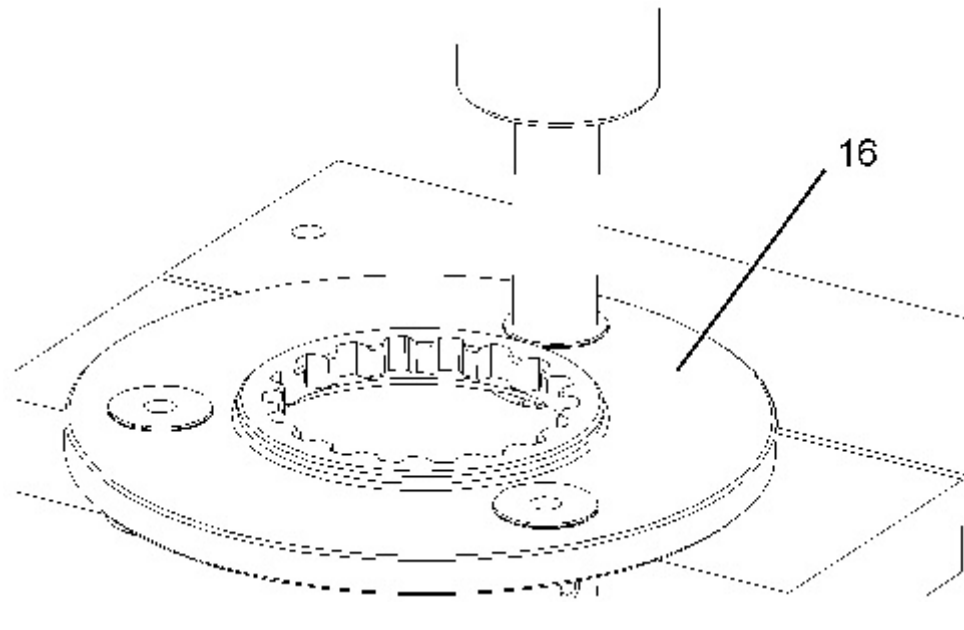

Illustration 9

g01389804

12. Use a suitable press to remove the shafts from carrier assembly (16).

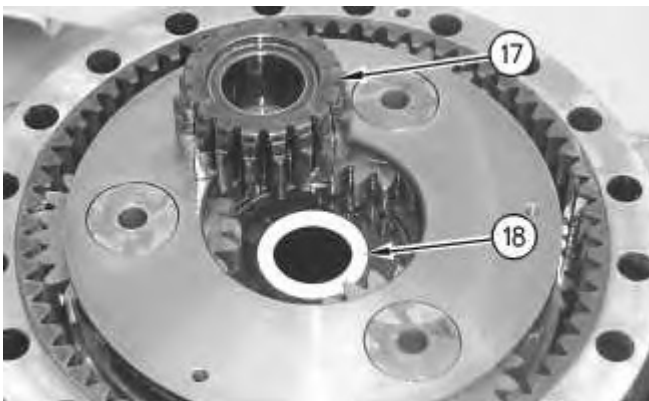

Illustration 10

g00892977

Thank you so much for reading.
Please click the “Buy Now!”
button below to download the
complete manual.



After you pay.

You can download the most
perfect and complete manual in
the world immediately.

Our support email:

ebooklibonline@outlook.com