



Service Repair Manual

Models

329E L EXCAVATOR

Product: EXCAVATOR

Model: 329E L EXCAVATOR RDX

Configuration: 329E & 329E L Excavators RDX00001-UP (MACHINE) POWERED BY C7.1 Engine

Disassembly and Assembly C7.1 Engines for Caterpillar Built Machines

Media Number -KENR8881-05

Publication Date -01/11/2012

Date Updated -10/05/2016

i03934057

Crankshaft Rear Seal - Install

SMCS - 1161-012

Installation Procedure With Oil Pan in Position

Table 1

Required Tools			
Tool	Part Number	Part Description	Qty
A	194-3536	T40 Torx Socket	1
B	227-4389	E10 Torx Socket	1

Note: The crankshaft rear seal and the housing are manufactured as one assembly.

Note: Do not lubricate the crankshaft rear seal or the crankshaft flange. The crankshaft rear seal must be installed dry.

NOTICE

Keep all parts clean from contaminants.

Contaminants may cause rapid wear and shortened component life.

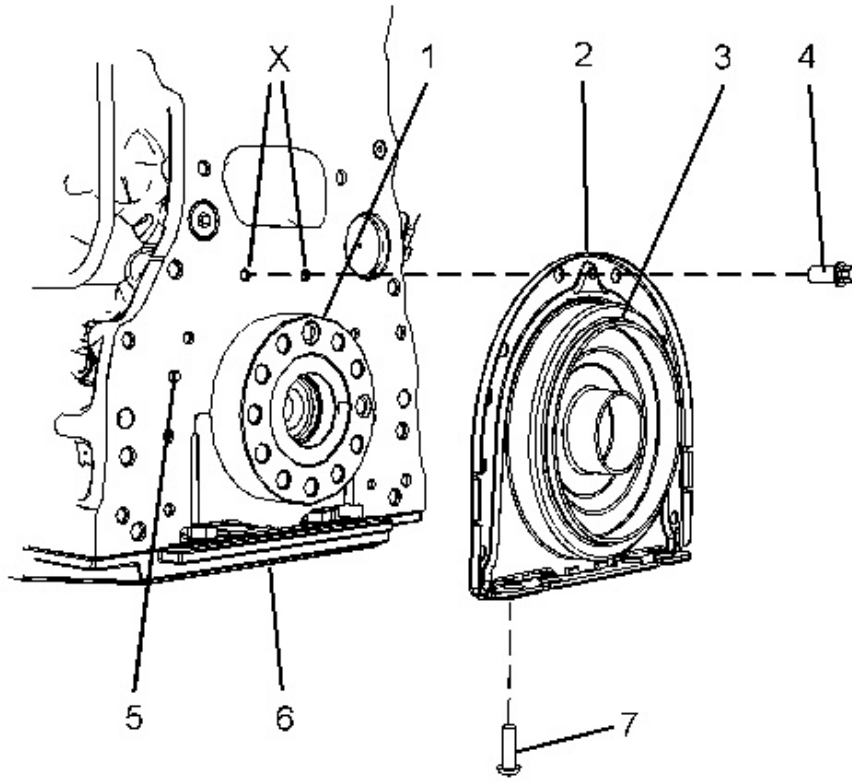

Illustration 1

g01986153

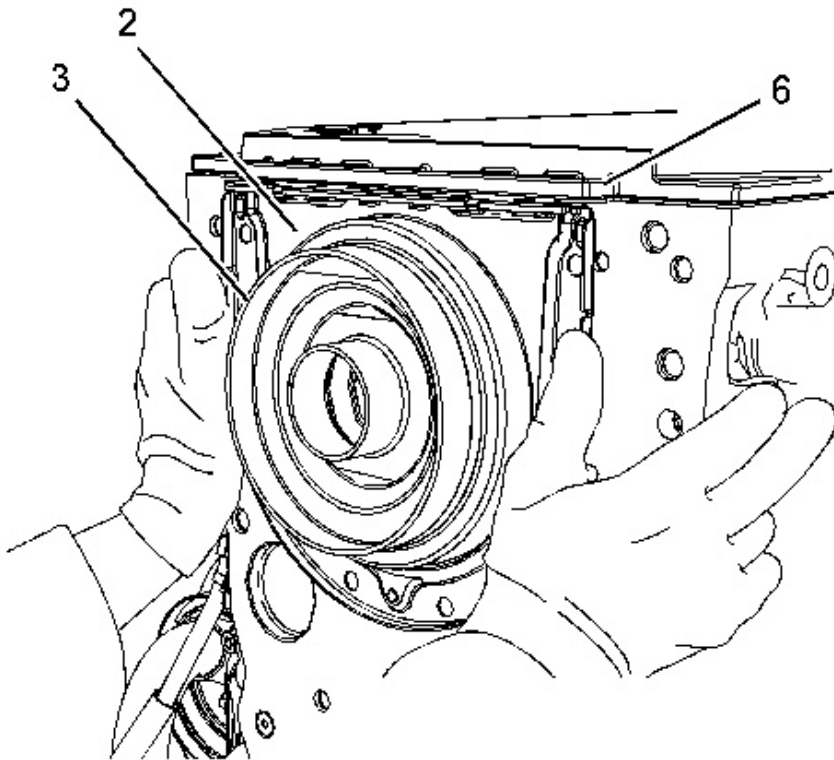

Illustration 2

g01986154

1. Ensure that crankshaft flange (1) is clean, dry, and free from damage.

2. Ensure that the gasket surface of the cylinder block is clean, free from damage, and dry. Ensure that the gasket surface of isolating frame (6) is clean and dry.
3. Ensure that plastic sleeve (3) is squarely installed within new crankshaft rear seal (2).

Note: The plastic sleeve is included in order to protect the lip of the seal as the crankshaft rear seal is pushed over crankshaft flange (1). Do not attempt to install a crankshaft rear seal without the plastic sleeve.

4. Place the assembly of crankshaft rear seal (2) over crankshaft flange (1). Align dowel (5) with the slot in crankshaft rear seal (2).
5. Ensure that plastic sleeve (3) is engaged on crankshaft flange (1). Push crankshaft rear seal (2) squarely onto the crankshaft. Ensure that the crankshaft rear seal is seated against the cylinder block. During this process, plastic sleeve (3) will be forced out of the crankshaft rear seal. Discard the plastic sleeve.

Note: Ensure that dowel (5) is engaged in the slot in the crankshaft rear seal.

6. Use Tooling (A) in order to install two outer Torx bolts (7) at the base of crankshaft rear seal (2). Tighten Torx bolts (7) to a torque of 15 N·m (133 lb in).
7. Use Tooling (B) in order to install two Torx bolts (4) to crankshaft rear seal (2) at Position (X). Tighten Torx bolts (4) to a torque of 22 N·m (195 lb in).
8. Use Tooling (A) in order to unscrew Torx bolts (7) by one complete turn.
9. Use Tooling (A) in order to install remaining Torx bolts (7). Tighten all Torx bolts (7) to a torque of 22 N·m (195 lb in).

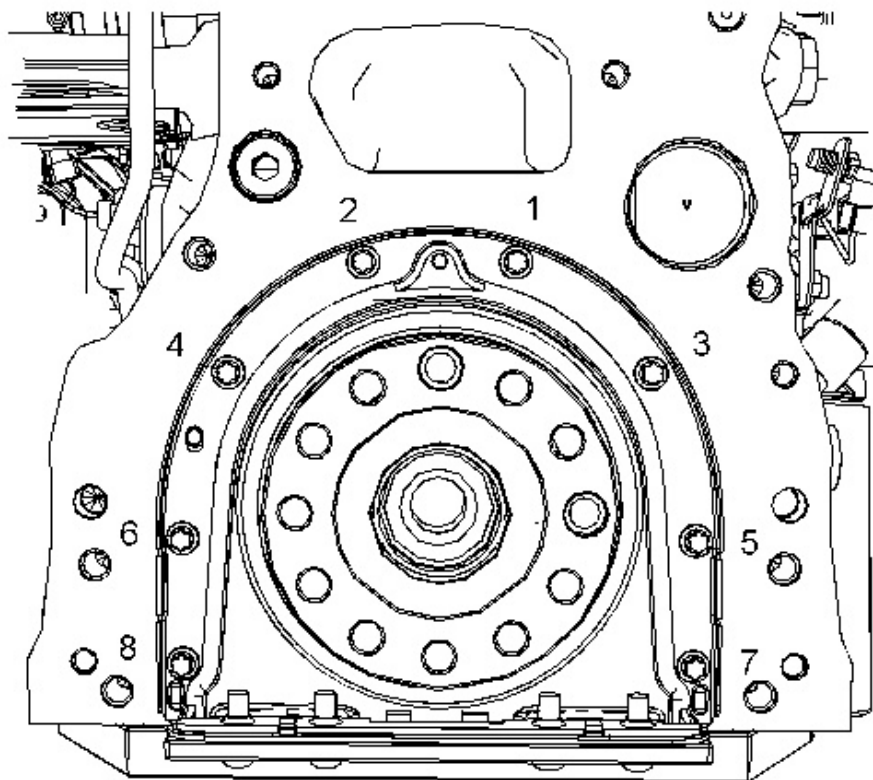

Illustration 3

g02047453

10. Tighten all Torx bolts (4) in the numerical sequence that is shown in Illustration 3. Tighten all Torx bolts (4) to a torque of 22 N·m (195 lb in).

End By:

- a. Install the flywheel housing. Refer to Disassembly and Assembly, "Flywheel Housing - Remove and Install" for the correct procedure.

Installation Procedure Without Isolating Frame for the Oil Pan

Table 2

Required Tools			
Tool	Part Number	Part Description	Qty
A	194-3536	T40 Torx Socket	1
C	-	Alignment Tool	1
	-	Bolts (M8 by 20 mm)	4

Note: The crankshaft rear seal and the housing are manufactured as one assembly.

Note: Do not lubricate the crankshaft rear seal or the crankshaft flange. The crankshaft rear seal must be installed dry.

NOTICE

Keep all parts clean from contaminants.

Contaminants may cause rapid wear and shortened component life.

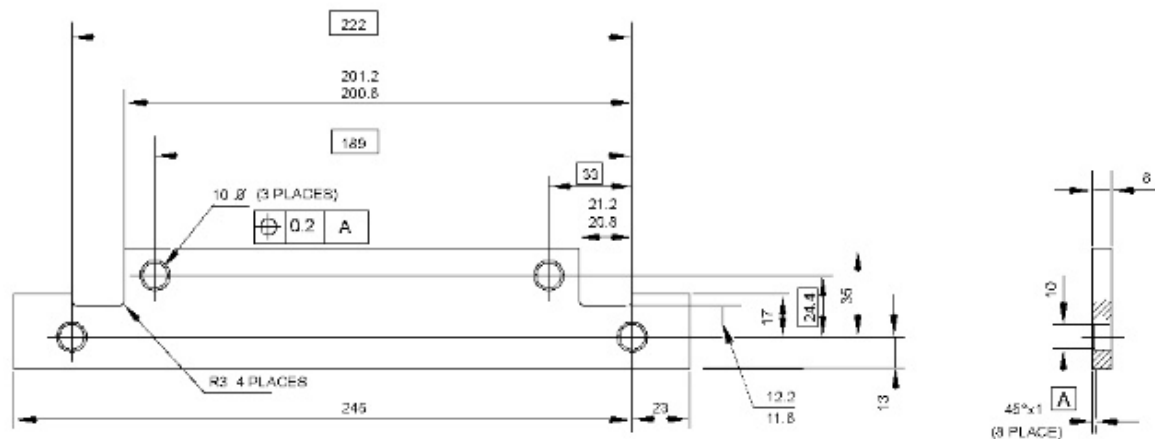

Illustration 4
Alignment tool

Thank you so much for reading.
Please click the “Buy Now!”
button below to download the
complete manual.



After you pay.

You can download the most
perfect and complete manual in
the world immediately.

Our support email:

ebooklibonline@outlook.com