



Service Repair Manual

Models

420D BACKHOE LOADER

Product: BACKHOE LOADER

Model: 420D BACKHOE LOADER BMC

Configuration: 420D Backhoe Loader BMC00611-UP (MACHINE) POWERED BY 3054 Engine

Disassembly and Assembly

416D, 420D, 424D, 428D, 430D, 432D, 438D and 442D Backhoe Loaders Power Train

Media Number -REN3578-12

Publication Date -01/04/2010

Date Updated -13/04/2010

i02047322

Steering Cylinder (Front) - Remove and Install

SMCS - 4303-010-FR

Removal Procedure

Table 1

Required Tools			
Tool	Part Number	Part Description	Qty
A	1P-2853	Spanner Wrench	1

Start By:

- A. Remove the tie rods from the axle. Refer to Disassembly and Assembly, "Tie Rod (Steering) (Front) - Remove and Install".



Cylinders equipped with lock valves can remain pressurized for very long periods of time, even with the hoses removed.

Failure to relieve pressure before removing a lock valve or disassembling a cylinder can result in personal injury or death.

Ensure all pressure is relieved before removing a lock valve or disassembling a cylinder.



Personal injury can result from hydraulic oil pressure and hot oil.

Hydraulic oil pressure can remain in the hydraulic system after the engine has been stopped. Serious injury can be caused if this pressure is not released before any service is done on the hydraulic system.

Make sure all of the work tools have been lowered to the ground, and the oil is cool before removing any components or lines. Remove the oil filler cap only when the engine is stopped, and the filler cap is cool enough to touch with your bare hand.

NOTICE

Care must be taken to ensure that fluids are contained during performance of inspection, maintenance, testing, adjusting and repair of the product. Be prepared to collect the fluid with suitable containers before opening any compartment or disassembling any component containing fluids.

Refer to Special Publication, NENG2500, "Caterpillar Tools and Shop Products Guide" for tools and supplies suitable to collect and contain fluids on Caterpillar products.

Dispose of all fluids according to local regulations and mandates.



Illustration 1

g00775110

1. Use Tooling (A) and remove spanner nut (1).
-

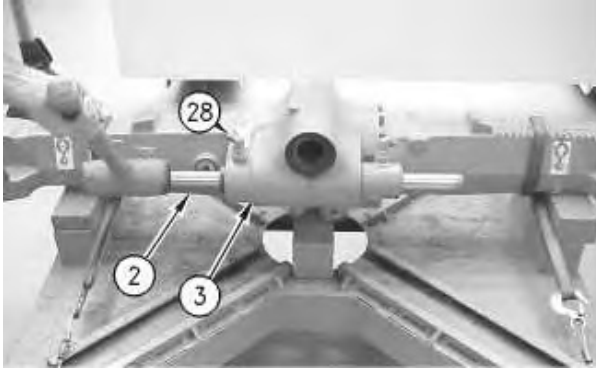

Illustration 2

g00775111

2. Use a rubber mallet in order to remove steering cylinder assembly (2) from axle housing (3) .

Disassembly Procedure



Cylinders equipped with lock valves can remain pressurized for very long periods of time, even with the hoses removed.

Failure to relieve pressure before removing a lock valve or disassembling a cylinder can result in personal injury or death.

Ensure all pressure is relieved before removing a lock valve or disassembling a cylinder.

NOTICE

Care must be taken to ensure that fluids are contained during performance of inspection, maintenance, testing, adjusting and repair of the product. Be prepared to collect the fluid with suitable containers before opening any compartment or disassembling any component containing fluids.

Refer to Special Publication, NENG2500, "Caterpillar Tools and Shop Products Guide" for tools and supplies suitable to collect and contain fluids on Caterpillar products.

Dispose of all fluids according to local regulations and mandates.

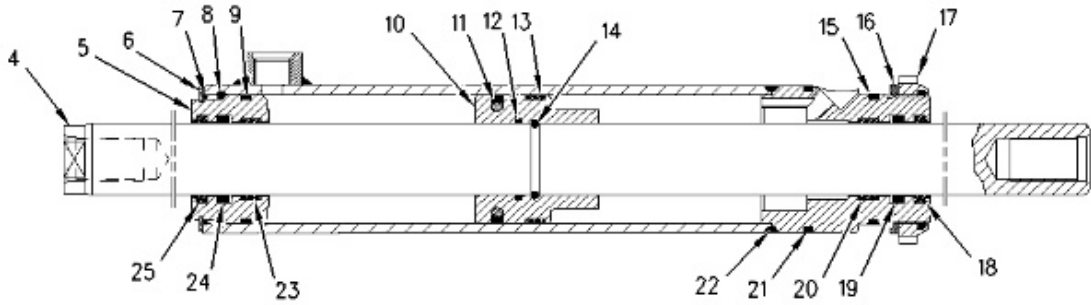

Illustration 3

g00775336

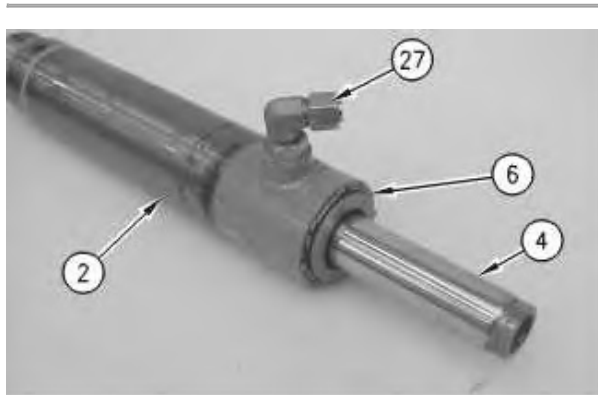

Illustration 4

g00775113

1. Remove retaining ring (6) .
2. Remove cap (27) .

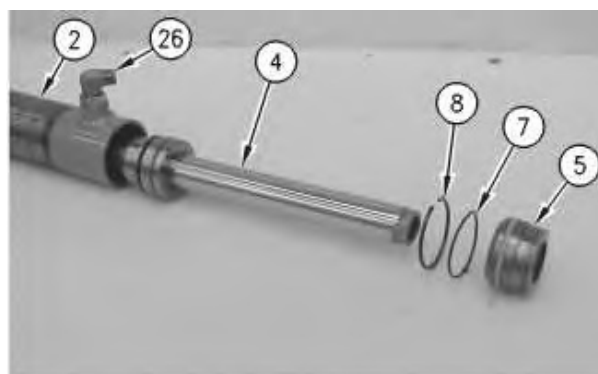

Illustration 5

g00775328

3. Push guide (5) into cylinder assembly (2). Remove snap ring (8) .
4. Remove guide (5) .
5. Remove O-ring seal (7) from guide (5) .
6. Remove fitting (26) .

Thank you so much for reading.
Please click the “Buy Now!”
button below to download the
complete manual.



After you pay.

You can download the most
perfect and complete manual in
the world immediately.

Our support email:

ebooklibonline@outlook.com