



Service Repair Manual

Models

420F Backhoe Loader

Product: BACKHOE LOADER

Model: 420F BACKHOE LOADER LKH

Configuration: 420F Backhoe Loader LKH00001-UP (MACHINE) POWERED BY C4.4 Engine

Disassembly and Assembly C4.4 (Mech) Engines for Caterpillar Built Machines

Media Number -KENR9210-10

Publication Date -01/12/2014

Date Updated -08/08/2018

i02763410

Exhaust Elbow - Remove and Install

SMCS - 1061-010-E4

Removal Procedure

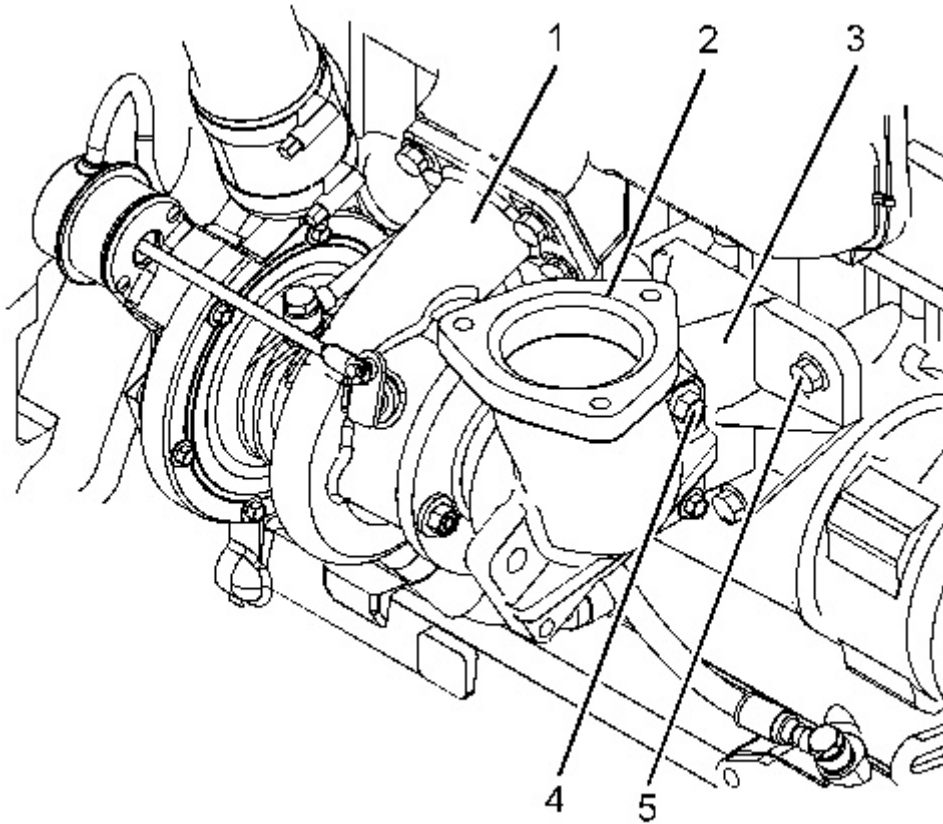

Illustration 1
Typical example

g01343547

1. Remove bolts (4) and remove exhaust elbow (2). Note the orientation of the exhaust elbow.
2. Remove bolts (5) and remove support bracket (3) from the cylinder block.

Installation Procedure

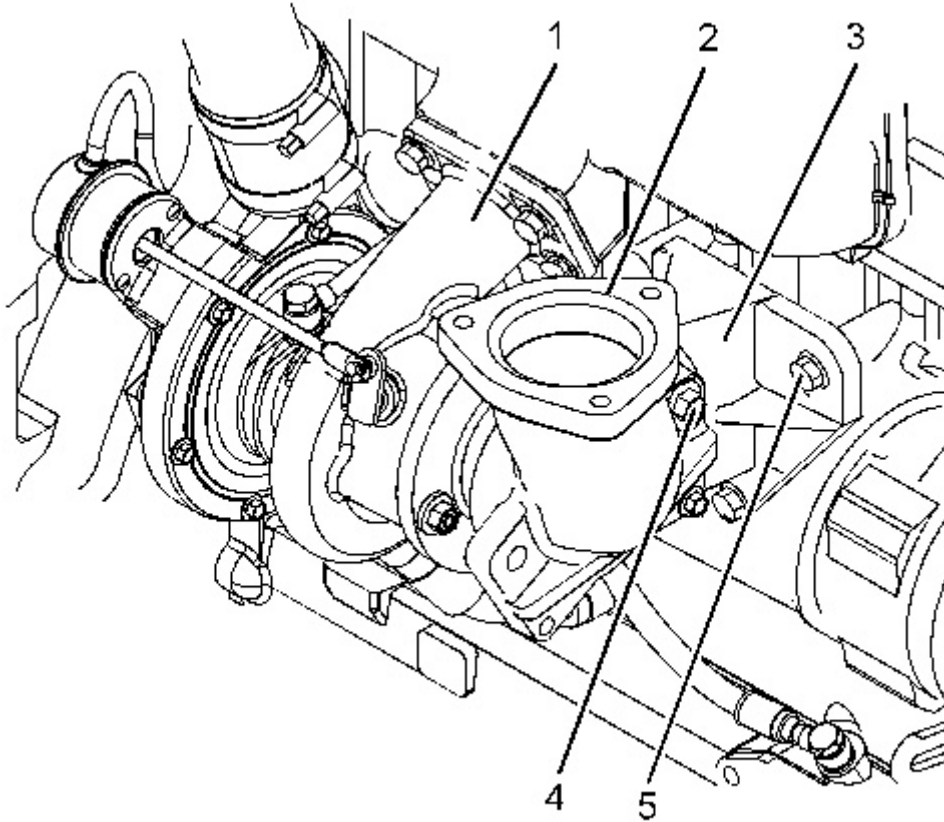

Illustration 2

g01343547

Typical example

1. Ensure that the exhaust elbow is clean and free from wear or damage.
2. Position support bracket (3) to the cylinder block and install bolts (5). Tighten bolts (5) to a torque of 44 N·m (33 lb ft).
3. Position exhaust elbow (2).

Note: Ensure the correct orientation of the exhaust elbow.

4. Install bolts (4) to support bracket (3). Tighten bolts (4) to a torque of 44 N·m (33 lb ft).

Product: BACKHOE LOADER

Model: 420F BACKHOE LOADER LKH

Configuration: 420F Backhoe Loader LKH00001-UP (MACHINE) POWERED BY C4.4 Engine

Disassembly and Assembly C4.4 (Mech) Engines for Caterpillar Built Machines

Media Number -KENR9210-10

Publication Date -01/12/2014

Date Updated -08/08/2018

i02763412

Inlet and Exhaust Valve Springs - Remove and Install

SMCS - 1108-010

Removal Procedure

Table 1

Required Tools			
Tool	Part Number	Part Description	Qty
A ⁽¹⁾	9U-6198	Crankshaft Turning Tool	1
A ⁽²⁾	9U-7336	Housing	1
	5P-7305	Engine Turning Tool	1
B	9U-6195	Valve Spring Compressor	1
	268-1969	Adapter	1
	276-1221	Head	1

⁽¹⁾ The Crankshaft Turning Tool is used on the front pulley.

⁽²⁾ This Tool is used in the aperture for the electric starting motor.

Start By:

- a. Remove the rocker shaft assembly. Refer to Disassembly and Assembly, "Rocker Shaft and Pushrod - Remove".

Note: Either Tooling (A) can be used. Use the Tooling that is most suitable.

NOTICE

Keep all parts clean from contaminants.

Contaminants may cause rapid wear and shortened component life.

Note: The following procedure should be adopted in order to remove the valve springs when the cylinder head is installed to the engine. Refer to Disassembly and Assembly, "Inlet and Exhaust Valves - Remove and Install" for the procedure to remove the valve springs from a cylinder head that has been removed from the engine.

Note: Ensure that the appropriate piston is at the top center position before the valve spring is removed. Failure to ensure that the piston is at the top center position may allow the valve to drop into the cylinder bore.

NOTICE

Plug the apertures for the push rods in the cylinder head in order to prevent the entry of loose parts into the engine.



Personal injury can result from being struck by parts propelled by a released spring force.

Make sure to wear all necessary protective equipment.

Follow the recommended procedure and use all recommended tooling to release the spring force.

NOTICE

Ensure that the valve spring is compressed squarely or damage to the valve stem may occur.

1. Follow Steps 1.a through 1.d in order to position the appropriate piston at top center.
 - a. Install Tooling (B) in position on the cylinder head in order to compress a valve spring for the appropriate piston.
 - b. Use Tooling (B) in order to compress valve spring (3) and open the valve slightly.

Note: Do not compress the spring so that valve spring retainer (2) touches the valve stem seal.

Thank you so much for reading.
Please click the “Buy Now!”
button below to download the
complete manual.



After you pay.

You can download the most
perfect and complete manual in
the world immediately.

Our support email:

ebooklibonline@outlook.com