



# Service Repair Manual

## **Models**

# 420F2 Backhoe Loader

---

Product: BACKHOE LOADER

Model: 420F2 BACKHOE LOADER HWD

Configuration: 420F2 IT Center Pivot Backhoe Loader HWD00001-UP (MACHINE) POWERED BY C4.4 Engine

## Disassembly and Assembly C4.4 Engines for Caterpillar Built Machines

Media Number -UENR4516-11

Publication Date -01/06/2015

Date Updated -29/10/2018

i05820268

# Inlet and Exhaust Valves - Remove and Install

SMCS - 1105-010

## Removal Procedure

Table 1

Required Tools			
Tool	Part Number	Part Description	Qty
A	9U-6195	Valve Spring Compressor	1
	268-1969	Adapter	1
	276-1221	Head	1

### Start By:

- a. Remove the cylinder head. Refer to Disassembly and Assembly, "Cylinder Head - Remove" for the correct procedure.

---

### NOTICE

**Keep all parts clean from contaminants.**

**Contaminants may cause rapid wear and shortened component life.**

---

1. Clean the bottom mating surface of the cylinder head. Check the depth of the valves below the face of the cylinder head before the valve springs are removed. Refer to Specifications, "Cylinder Head Valves" for the correct dimensions.

2. Place a temporary identification mark on the heads of the valves in order to identify the correct position.

**Note:** Inlet valves have a recess in the center of the head.

3. Use a suitable lifting device to position the cylinder head with the valve springs upward. The weight of the cylinder head is approximately 65 kg (143 lb).

**Note:** Ensure that the cylinder head is kept on a clean, soft surface in order to prevent damage to the machined face.

## **WARNING**

**Personal injury can result from being struck by parts propelled by a released spring force.**

**Make sure to wear all necessary protective equipment.**

**Follow the recommended procedure and use all recommended tooling to release the spring force.**

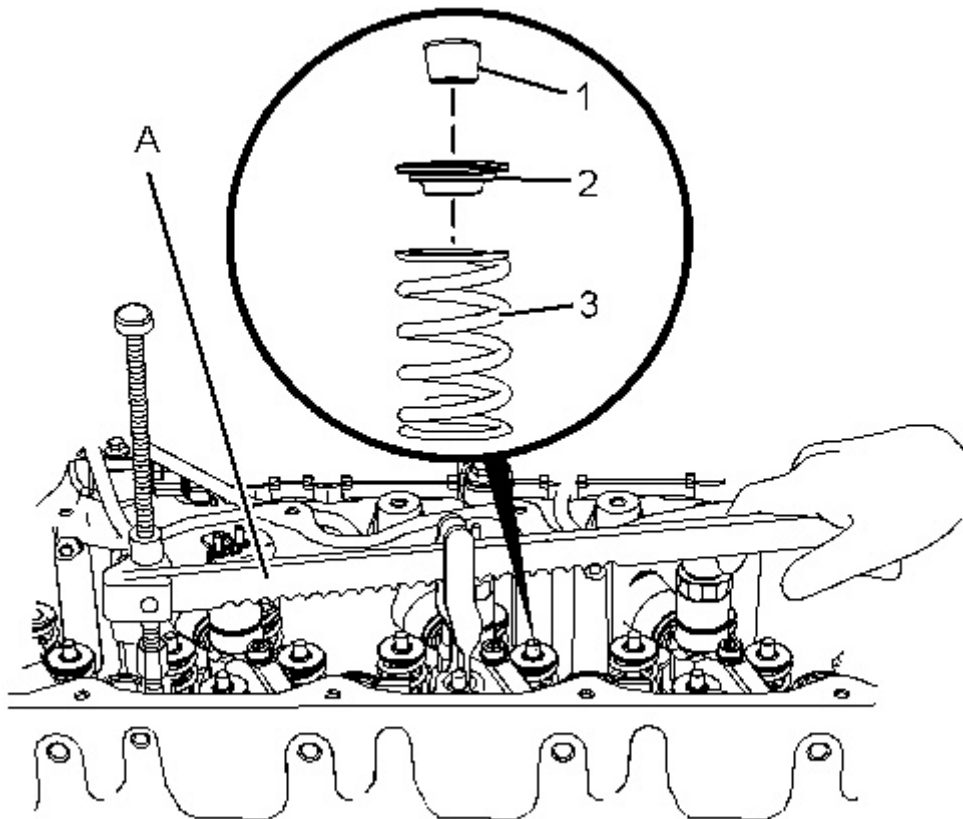

4. Install Tooling (A) in position on the cylinder head in order to compress appropriate valve spring (3).

---

### NOTICE

**Ensure that the valve spring is compressed squarely or damage to the valve stem may occur.**

---

5. Apply sufficient pressure to Tooling (A) in order to remove valve keepers (1).

**Note:** Do not compress the spring so that valve spring retainer (2) touches valve stem seal (4).

6. Slowly release pressure on Tooling (A).

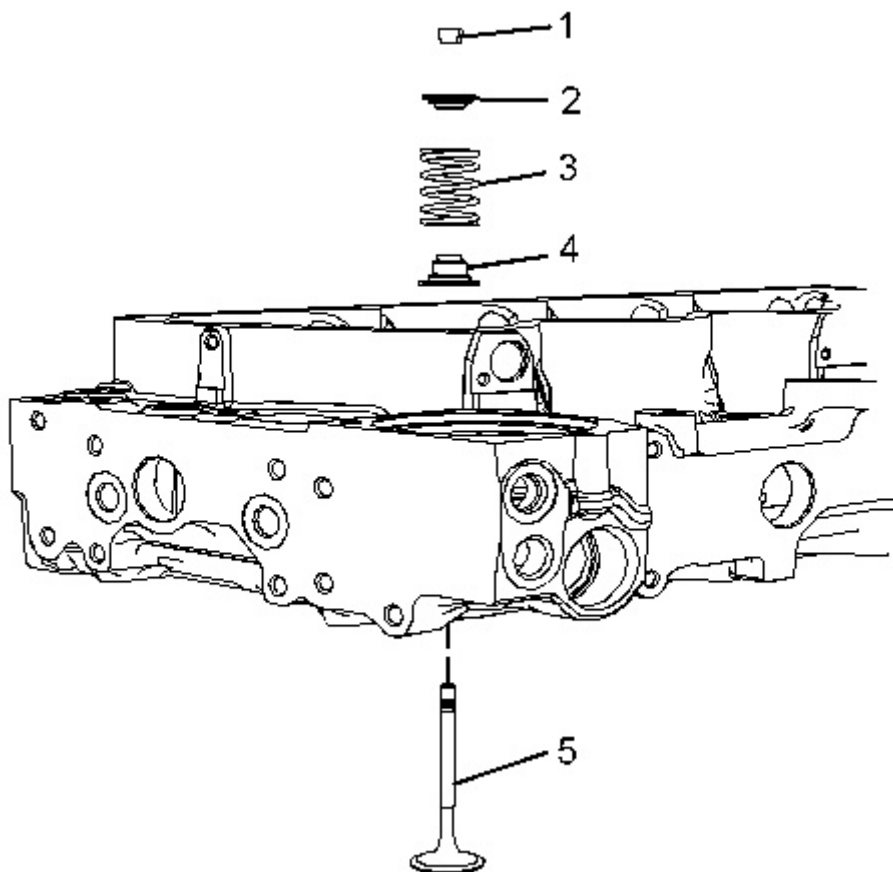

---

Illustration 2

g02511676

7. Place a temporary identification mark on valve spring (3) in order to identify the correct position.
8. Remove valve spring retainer (2). Remove valve spring (3).
9. Repeat Step 4 through Step 8 for the remaining valves.

10. Remove Tooling (A).
11. Remove valve stem seals (4).
12. Use a suitable lifting device in order to carefully turn over the cylinder head.
13. Remove valves (5).

## Installation Procedure

Table 2

Required Tools			
Tool	Part Number	Part Description	Qty
A	9U-6195	Valve Spring Compressor	1
	268-1969	Adapter	1
	276-1221	Head	1

---

### NOTICE

**Keep all parts clean from contaminants.**

**Contaminants may cause rapid wear and shortened component life.**

---

**Note:** The valves have a hard surface finish. Grinding compound must not be used on the valves. Grinding compound will damage the hard surface finish of the valves.

1. Clean all components of the cylinder head assembly. Ensure that all ports, all coolant passages, and all lubrication passages in the cylinder head are free from debris. Follow Step 1.a through Step 1.d in order to inspect the components of the cylinder head assembly. Replace any components that are worn or damaged.
  - a. Inspect the cylinder head for wear and for damage. Refer to System Operation, Testing and Adjusting, "Cylinder Head Inspect" for the correct procedure.
  - b. Inspect the valve seats for wear and for damage. Refer to Specifications, "Cylinder Head Valves" for further information.
  - c. Inspect the valve guides for wear and for damage. Refer to Specifications, "Cylinder Head Valves" and System Operation, Testing and Adjusting, "Valve Guide - Inspect" for further information.
  - d. Inspect the valves for wear and for damage. Refer to Specifications, "Cylinder Head Valves" for further information.
  - e. Inspect valve springs (3) for damage and for the correct length. Refer to Specifications, "Cylinder Head Valves " for further information.

Thank you so much for reading.  
Please click the “Buy Now!”  
button below to download the  
complete manual.



After you pay.

You can download the most  
perfect and complete manual in  
the world immediately.

Our support email:

[ebooklibonline@outlook.com](mailto:ebooklibonline@outlook.com)