



# Service Repair Manual

## **Models**

# 424D Backhoe Loader

---

Product: BACKHOE LOADER

Model: 424D BACKHOE LOADER BKR

Configuration: 424D Backhoe Loader BKR00001-00528 (MACHINE) POWERED BY 3054 Engine

## Disassembly and Assembly

### 416D, 420D, 424D, 428D, 430D, 432D, 438D and 442D Backhoe Loaders Power Train

Media Number -REN3578-12

Publication Date -01/04/2010

Date Updated -13/04/2010

i01381641

## Transmission (Direct Drive) - Assemble

SMCS - 3030-016-DD; 3066-016

### Assembly Procedure

Table 1

Required Tools			
Tool	Part Number	Part Description	Qty
A	137-8102	Spring Compressor	1
B	1P-1859	Snap Ring Pliers	1
C	4C-3652	Spring Compressor	1
D	6V-2157	Link Bracket	1
E	8T-5096	Indicator	1
F	1U-5750	Engine Stand	1

**Note:** The transmission will be assembled in major components. The major components will then be assembled.

**Note:** Cleanliness is an important factor. Before assembly, all parts should be thoroughly cleaned in cleaning fluid. Allow the parts to air dry. Wiping cloths or rags should not be used to dry parts. Lint may be deposited on the parts which may cause later trouble. Inspect all parts. If any parts are worn or damaged, use new parts for replacement.

**Note:** Apply a light film of clean transmission oil to all components before assembly.

## Transmission case

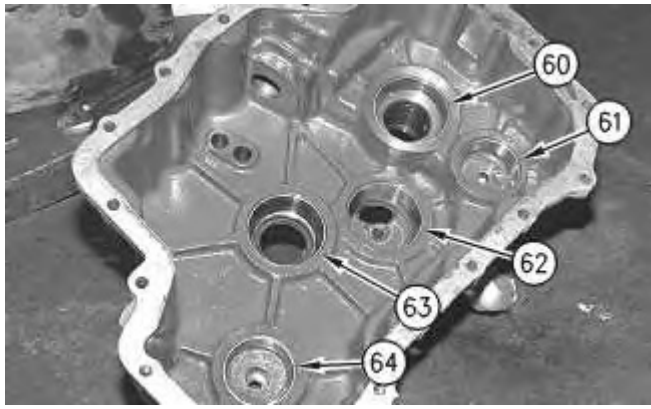

Illustration 1

g00729262

**Note:** Install the shims behind each bearing cup that was recorded on the disassembly procedure.

1. Install bearing cups (60), (61), (62), (63), and (64) .

## (Direct Drive) Input Shaft

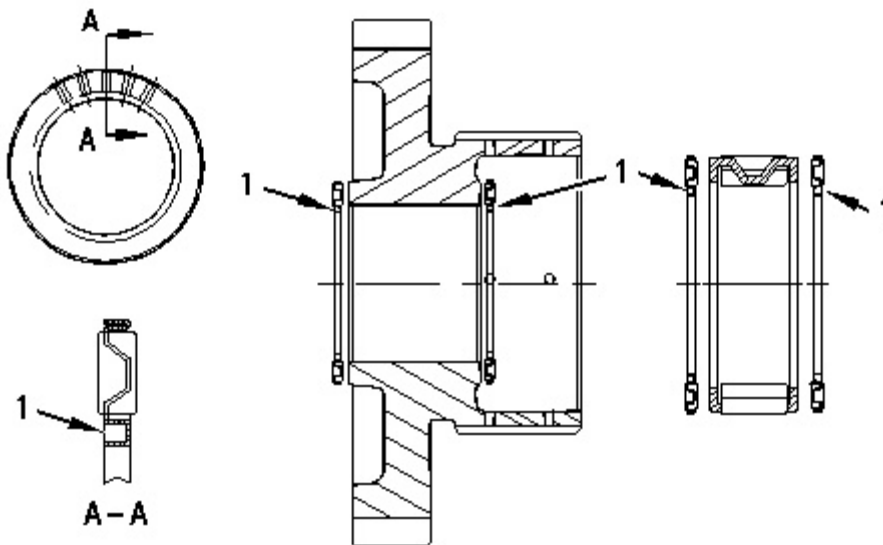

Illustration 2

g00731364

1. Install the needle thrust bearings on the shafts. The open end of cups (1) must point away from the bearings or gears that are contacted.
-

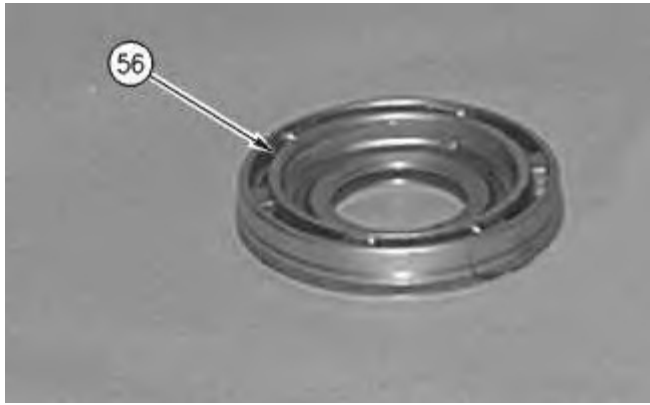

Illustration 3

g00729745

2. Install the seals on piston (56) .

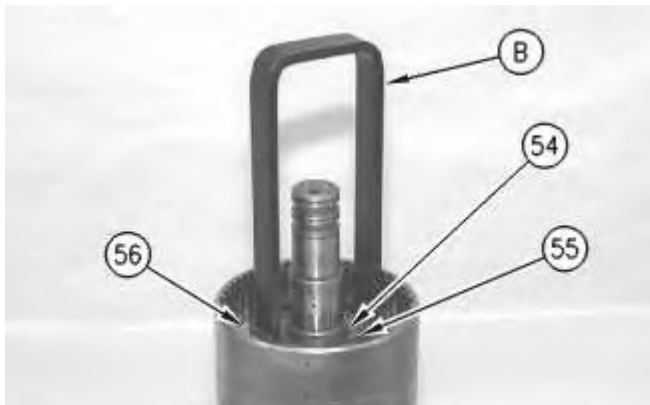

Illustration 4

g00729752

3. Install piston (56). Install the retainer and spring (55). Use tooling (A) and a suitable press in order to compress spring (55). Use tooling (B) in order to install snap ring (54) .

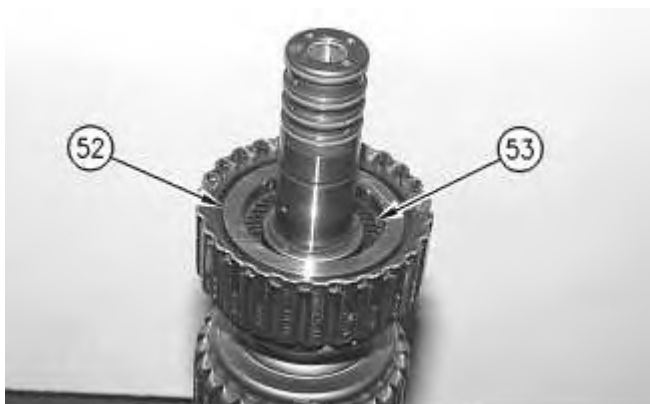

Illustration 5

g00729210

4. Install clutch pack (53) and retainer (52) .
5. Repeat Steps 2 through 4 for the opposite end of the input shaft.

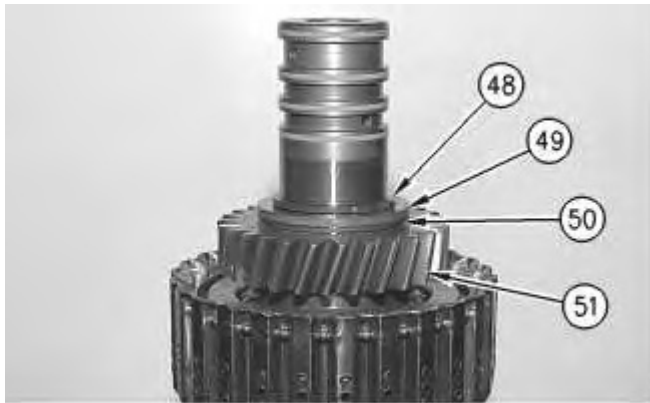

Illustration 6

g00729208

6. Install gear (51), needle bearing (50), and spacer (49). Use tooling (B) in order to install snap ring (48) .

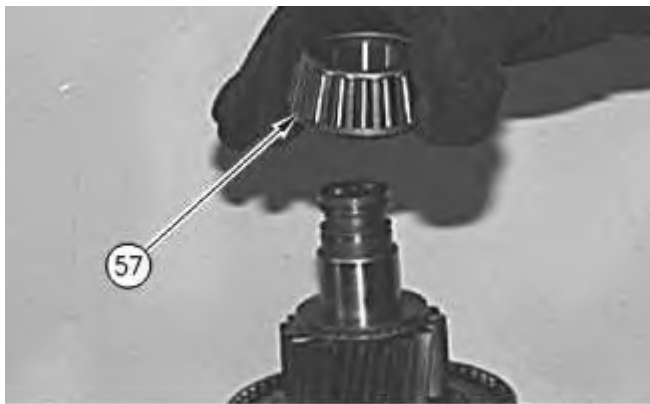

Illustration 7

g00729771

7. Heat bearing cone (57) to 135 °C (275 °F). Install bearing cone (57) .
8. Install the input shaft.

## **(Direct Drive) Reverse Shaft**

---

Thank you so much for reading.  
Please click the “Buy Now!”  
button below to download the  
complete manual.



After you pay.

You can download the most  
perfect and complete manual in  
the world immediately.

Our support email:

[ebooklibonline@outlook.com](mailto:ebooklibonline@outlook.com)