



Service Repair Manual

Models

444F Backhoe Loader

Product: BACKHOE LOADER

Model: 444F BACKHOE LOADER LJJ

Configuration: 444F Backhoe Loader LJJ00001-UP (MACHINE) POWERED BY C4.4 Engine

Disassembly and Assembly C4.4 (Mech) Engines for Caterpillar Built Machines

Media Number -KENR9210-10

Publication Date -01/12/2014

Date Updated -08/08/2018

i02763436

Idler Gear - Install

SMCS - 1206-012

Installation Procedure (Standard Idler Gear)

Table 1

Required Tools			
Tool	Part Number	Part Description	Qty
A	230-6284	Timing Pin (Camshaft)	1
B	230-6283	Timing Pin (Crankshaft)	1
C	9U-7324	Indicator Bracket	1
	7H-1942	Dial Indicator	1
	3S-3268	Indicator Contact Point	1
	7H-1940	Universal Attachment	1

NOTICE

Keep all parts clean from contaminants.

Contaminants may cause rapid wear and shortened component life.

1. Ensure that number one piston is at the top center position on the compression stroke. Refer to the Systems Operation, Testing and Adjusting, "Finding Top Center Position for No. 1 Piston".
-

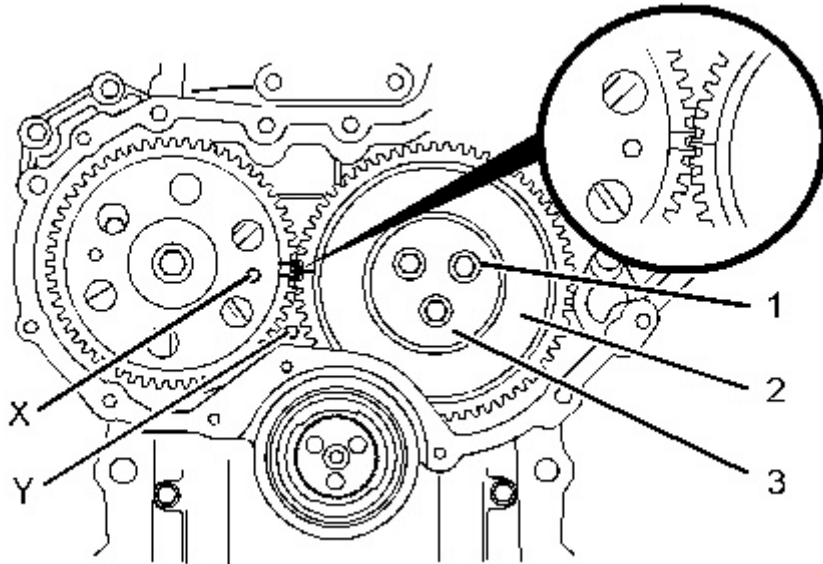

Illustration 1

g01343975

Alignment of timing marks

2. Ensure that Tooling (A) is installed into hole (X) in camshaft gear (1).
3. Ensure that Tooling (B) is installed in hole (Y) in the front housing. Use Tooling (B) in order to lock the crankshaft in the correct position. Refer to Systems Operation, Testing and Adjusting, "Finding Top Centre Position for No.1 Piston".

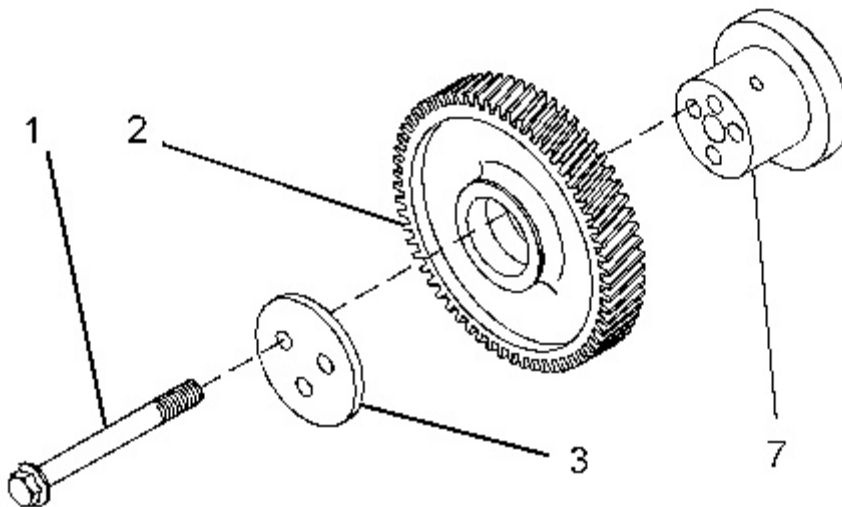

Illustration 2

g01269934

4. Clean idler gear (2) and inspect the idler gear for wear or damage. Refer to Specifications, "Gear Group (Front)" for more information. If necessary, replace the idler gear.
5. Clean hub (7) and inspect the hub for wear or damage. Refer to Specifications, "Gear Group (Front)" for more information. If necessary, replace the hub.

- Lubricate hub (7) with clean engine oil. Slide the hub into idler gear (2). Ensure that the timing marks are toward the front of the idler gear.
-

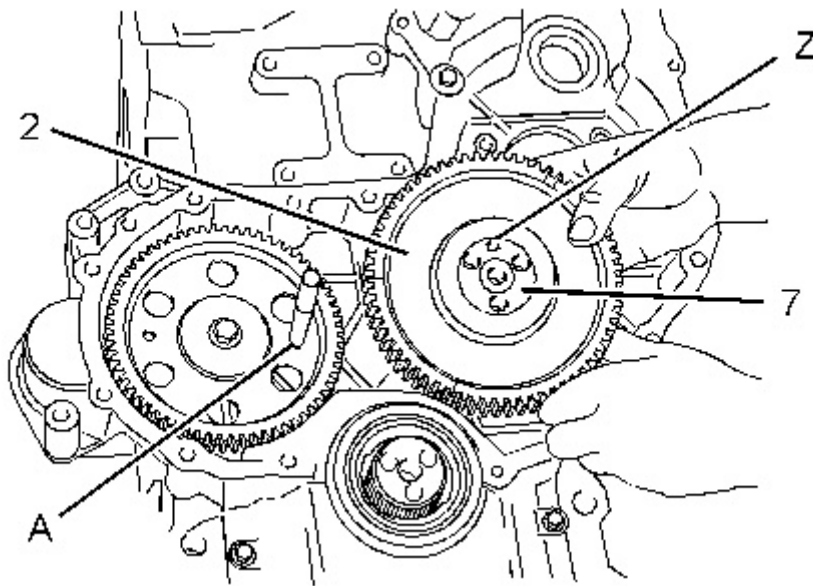

Illustration 3

g01269935

Typical example

- Align the timing mark on idler gear (2) with the timing mark on the camshaft gear. Refer to the Illustration 1. Install the assembly of idler gear (2) and hub (7) into the recess in the timing case. Ensure that oil hole (Z) is to the top of the hub.
- Note:** The idler gear must be tilted during installation. Ensure that the holes in the hub are aligned with the holes in the cylinder block.
- Clean plate (3) and inspect the plate for wear or damage. If necessary, replace the plate.
 - Lubricate plate (3) with clean engine oil. A used plate should be installed in the original orientation. If a new plate is installed, ensure that the holes in plate (3) are aligned with the holes in hub (7). Install plate (3) to hub (7).
 - Install bolts (1). Tighten bolts (1) to a torque of 44 N·m (32 lb ft).
-

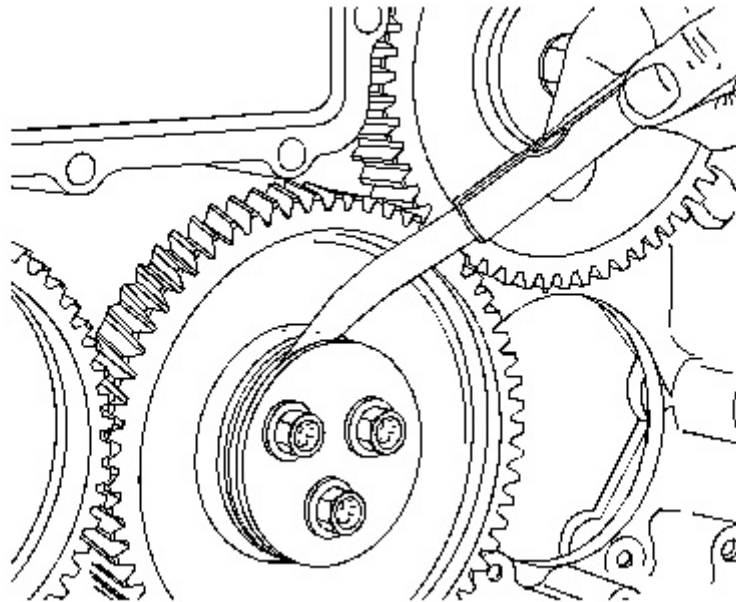

Illustration 4

g01269936

Checking end play by using a set of feeler gauge's

11. Use a set of feeler gauge's in order to check the end play for the idler gear. Refer to Specifications, "Gear Group (Front)" for more information.
12. Use Tooling (C) in order to check the backlash between the idler gear and the camshaft gear. Refer to Specifications, "Gear Group (Front)" for more information.
13. Use Tooling (C) in order to check the backlash between the idler gear and the crankshaft gear. Refer to Specifications, "Gear Group (Front)" for more information.
14. Lightly lubricate all of the gears with clean engine oil.

End By:

- a. Install the fuel injection pump gear. Refer to Disassembly and Assembly, "Fuel Pump Gear - Install".
- b. If the engine is equipped with an air compressor, install the air compressor. Refer to Disassembly and Assembly, "Air Compressor - Remove and Install".
- c. If the engine is equipped with a vacuum pump, install the vacuum pump. Refer to Disassembly and Assembly, "Vacuum Pump - Remove and Install".
- d. If the engine is equipped with an accessory drive, install the accessory drive. Refer to Disassembly and Assembly, "Accessory Drive - Remove and Install".

Installation Procedure (Heavy-Duty Idler Gear)

Table 2

Required Tools			
Tool	Part Number	Part Description	Qty

Thank you so much for reading.
Please click the “Buy Now!”
button below to download the
complete manual.



After you pay.

You can download the most
perfect and complete manual in
the world immediately.

Our support email:

ebooklibonline@outlook.com