



Service Repair Manual

Models

735 ARTICULATED TRUCK

Product: ARTICULATED TRUCK

Model: 735 ARTICULATED TRUCK 3T5

Configuration: 735 Articulated Truck 3T500001-UP (MACHINE) POWERED BY C13 Engine

Disassembly and Assembly C13 Engine for Caterpillar Built Machines

Media Number -UENR0131-06

Publication Date -01/05/2015

Date Updated -27/06/2018

i05351533

Flywheel Housing - Remove and Install

SMCS - 1157-010

Removal Procedure

Table 1

Required Tools			
Tool	Part Number	Part Description	Qty
A	138-7574	Link Brackets	2
B	8C-8422	Sealant	-

Start By:

- A. Remove the flywheel.
- B. Remove the crankshaft rear seal.

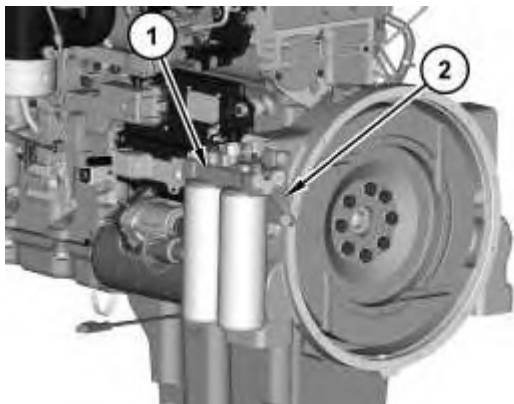

1. If necessary, remove fuel filter base (1) and reposition fuel filter base (1). Remove bracket (2) .

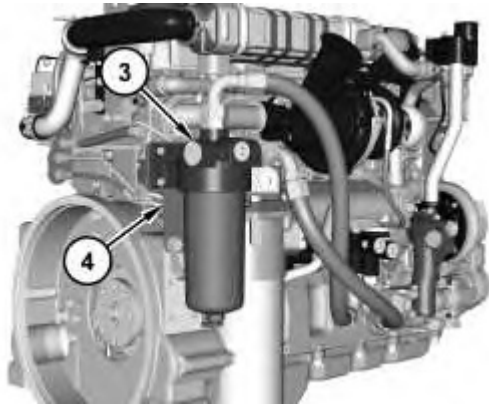

Illustration 2

g01870417

2. If necessary, remove oil filter base (3) and reposition oil filter base (3). Remove bracket (4) .

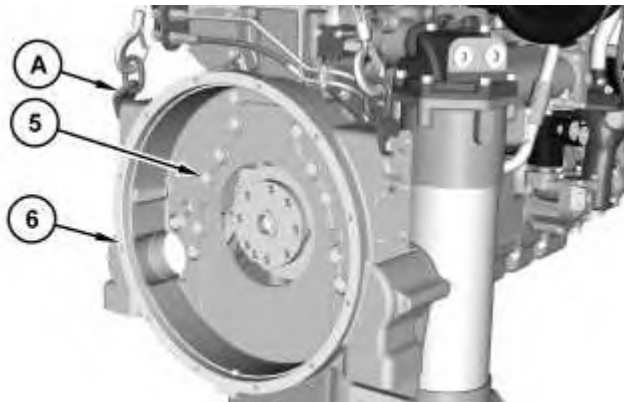

Illustration 3

g01870418

3. Install Tooling (A) and a suitable lifting device to flywheel housing (6). The weight of flywheel housing (6) is approximately 64 kg (140 lb). Remove bolts (5) and flywheel housing (6) .

Installation Procedure

1. Install flywheel housing (6) in the reverse order of removal.
 - a. Apply Tooling (B) to the backside of flywheel housing (6). Install within 10 minutes of application.

Product: ARTICULATED TRUCK

Model: 735 ARTICULATED TRUCK 3T5

Configuration: 735 Articulated Truck 3T500001-UP (MACHINE) POWERED BY C13 Engine

Disassembly and Assembly C13 Engine for Caterpillar Built Machines

Media Number -UENR0131-06

Publication Date -01/05/2015

Date Updated -27/06/2018

i03542628

Vibration Damper and Pulley - Remove and Install

SMCS - 1205-010

Removal Procedure

Table 1

Required Tools			
Tool	Part Number	Part Description	Qty
A	8T-0514	Guide Stud	1

1. Remove the belt. Refer to Operation and Maintenance Manual, "Belt - Inspect/Adjust/Replace".

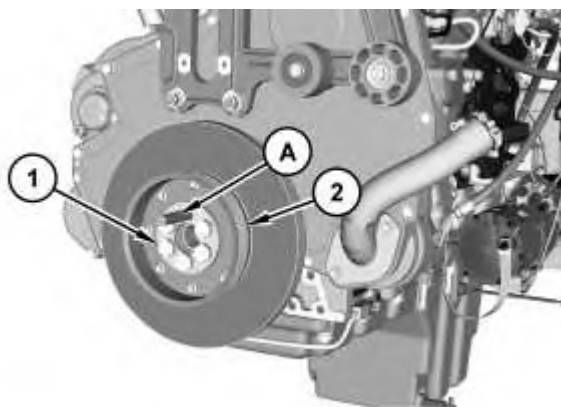

Illustration 1

g01870577

2. Remove one of bolts (1). Install Tooling (A). Remove remaining bolts (1) and pulley assembly (2).

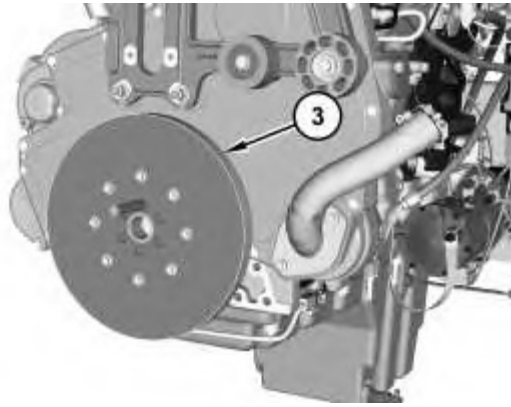

Illustration 2

g01870580

3. Remove vibration damper (3).

Installation Procedure

1. Install vibration damper (3) and pulley assembly (2) in reverse order of removal.

Thank you so much for reading.
Please click the “Buy Now!”
button below to download the
complete manual.



After you pay.

You can download the most
perfect and complete manual in
the world immediately.

Our support email:

ebooklibonline@outlook.com