



Service Repair Manual

Models

**735 OEM ARTICULATED
TRUCK**

Product: ARTICULATED TRUCK

Model: 735 OEM ARTICULATED TRUCK WWC

Configuration: 735 OEM Articulated Truck WWC00001-UP (MACHINE) POWERED BY C15 Engine

Disassembly and Assembly C15 and C18 Engines for Caterpillar Built Machines

Media Number -REN8261-28

Publication Date -01/08/2015

Date Updated -28/08/2018

i07435098

Rear Power Take-Off (RPTO) - Install - If Equipped

SMCS - 1165-012-RE

Installation Procedure

Table 1

Required Tools			
Tool	Part Number	Part Description	Qty
A	1P-0520	Driver Group	1

NOTICE

Keep all parts clean from contaminants.

Contaminants may cause rapid wear and shortened component life.

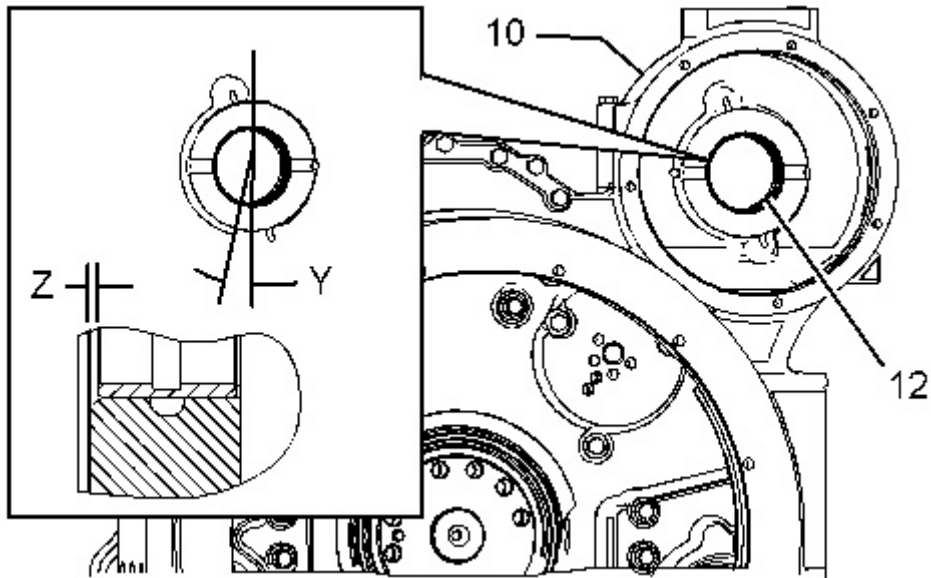

Illustration 1

g01134277

1. Install sleeve bearing (12) in the flywheel housing with Tooling (A). The split in the sleeve bearing should be located at Angle (Y), which is 15 ± 1 degrees from the vertical centerline. The bearing should be installed to Depth (Z), which is 2.0 ± 0.5 mm (0.08 ± 0.02 inch).
2. Install cover (10) and the bolts on the back side of the flywheel housing.

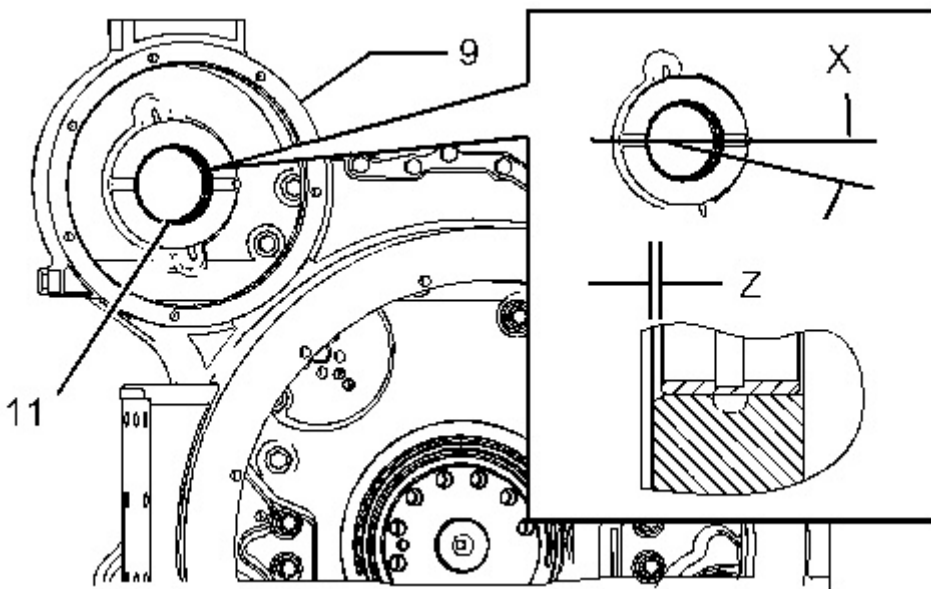

Illustration 2

g01134279

3. Install sleeve bearing (11) in the flywheel housing with Tooling (A). The split in the sleeve bearing should be located at Angle (X), which is 15 ± 1 degrees from the horizontal centerline. The bearing should be installed to Depth (Z), which is 2.0 ± 0.5 mm (0.08 ± 0.02 inch).
4. Install cover (9) and the bolts on the back side of the flywheel housing.

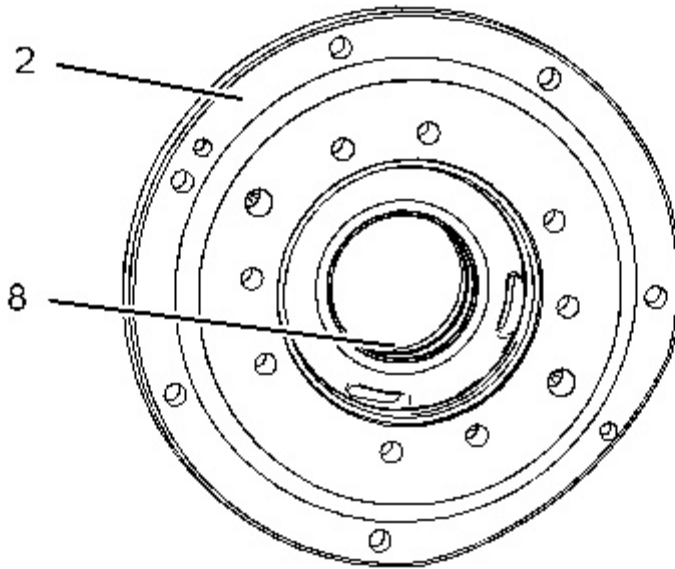

Illustration 3

g01134263

5. Use Tooling (A) and install sleeve bearing (8) in adapter (2). Install the O-ring seal on the adapter.

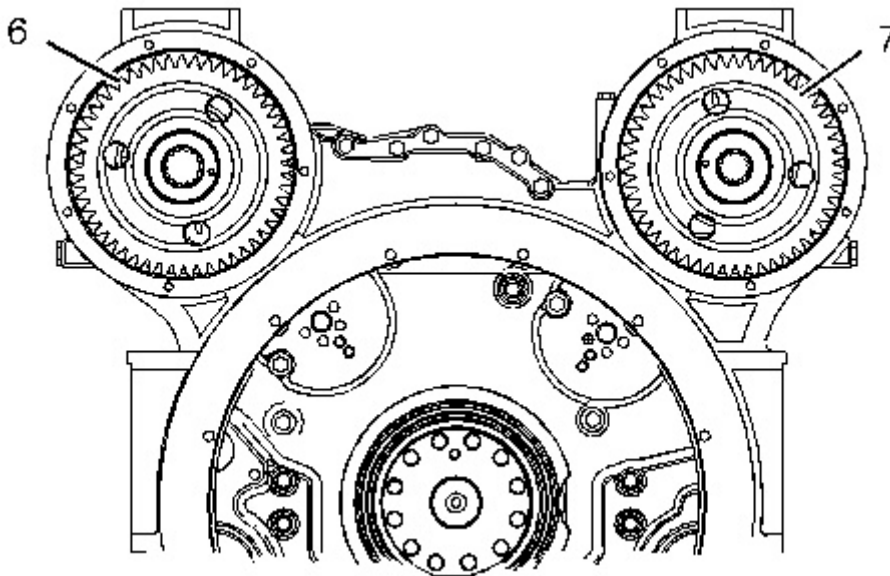

Illustration 4

g01134262

6. Position gear assembly (6) and gear assembly (7) in the flywheel housing.
-

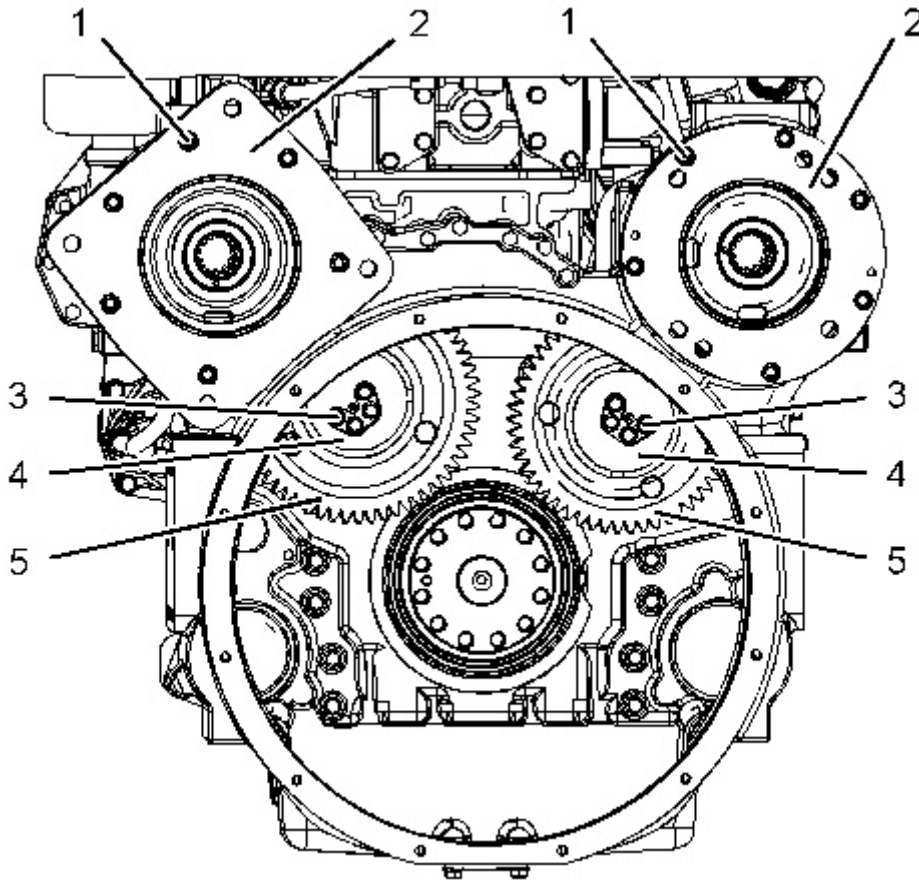

Illustration 5

g01115921

7. Position idler gears (5) and retainer assemblies (4). Install bolts (3). Tighten bolts (3) to a torque of 100 ± 20 N·m (74 ± 15 lb ft).
8. Lubricate the O-ring seal on the adapters with clean engine oil. Position adapters (2) on the flywheel housing and install bolts (1).

End By:

- a. Install the flywheel. Refer to Disassembly and Assembly, "Flywheel - Install".

Thank you so much for reading.
Please click the “Buy Now!”
button below to download the
complete manual.



After you pay.

You can download the most
perfect and complete manual in
the world immediately.

Our support email:

ebooklibonline@outlook.com