



# Service Repair Manual

## **Models**

# 735C ARTICULATED TRUCK

---

Product: ARTICULATED TRUCK

Model: 735C ARTICULATED TRUCK LFJ

Configuration: 735C Articulated Truck LFJ00001-UP (MACHINE) POWERED BY C15 Engine

## Disassembly and Assembly 735C, 740C EJECTOR and 745C Articulated Trucks Power Train

Media Number -UENR4227-04

Publication Date -01/09/2015

Date Updated -02/07/2018

i06222650

# Hitch Drive Shaft Bearings - Install

SMCS - 3253-012-BD

## Installation Procedure

Table 1

Required Tools			
Tool	Part Number	Part Description	Qty
A	1P-0520	Driver Group	1
B	136-1452	Internal Tip Pliers	1
C	5P-0960	Grease Cartridge	1
D	5P-3931	Anti-Seize Compound	1

**Note:** The machine has the ability to split, ensure wheel chocks are in place.

**Note:** Cleanliness is an important factor. Before the installation procedure, the exterior of the component should be thoroughly cleaned. This will help to prevent dirt from entering the internal mechanism.

---



Illustration 1

g00783742

1. Install O-ring seal (21) onto bearing carrier (8).
2. Use Tooling (A) in order to install new lip seal (20) into the bearing carrier (8). Fill in 1/3 of the cavity bearing carrier (8) with Tooling (C) in order to lubricate lip seal (20).



Illustration 2

g00783741

View from the hitch area.

3. Position bearing carrier (8) onto the hitch tube. Install bolts (19) in order to connect bearing carrier (8) to the hitch tube.

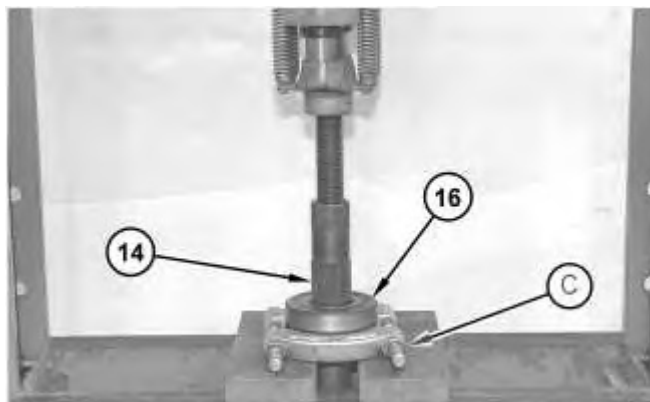

Illustration 3

g01196527

4. Raise the temperature of bearing (16) in order to install bearing (16) onto hitch drive shaft (14). Turn over hitch drive shaft (14) and install retaining ring (15) that is used to secure bearing (16) to bearing carrier (4) in step 6. Repeat the procedure in order to install the bearing onto the opposite end of the hitch drive shaft (14).

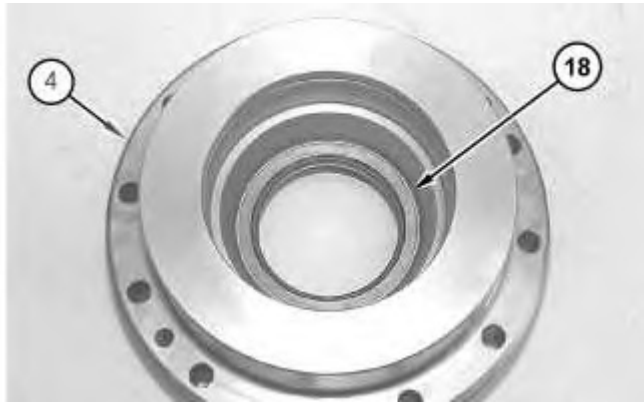

Illustration 4

g01196525

5. Use Tooling (A) in order to install new lip seal (18) into bearing carrier (4). Fill in 1/3 of the cavity bearing carrier (4) with Tooling (C) in order to lubricate lip seal (18).

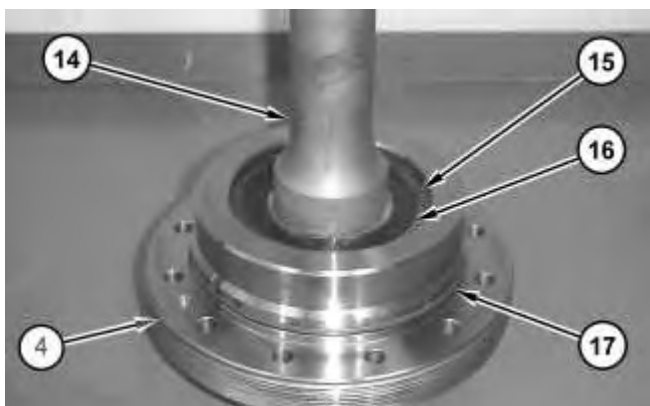

Illustration 5

g01196521

6. Install O-ring seal (17) onto bearing carrier (4). Install hitch drive shaft (14) and roller bearing (16) into bearing carrier (4). Use Tooling (B) in order to install retaining ring (15) into bearing carrier (4).
-

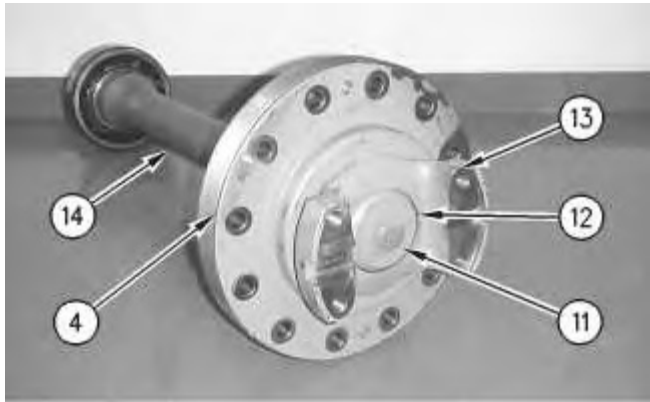

Illustration 6

g00783239

7. Coat the splines at the end of hitch drive shaft (14) with grease. Install shaft yoke (13) and the O-ring seal onto hitch drive shaft (14). Install bolt (11) and washer (12) in order to secure shaft yoke (13) to the bearing carrier (4) and the hitch drive shaft (14).

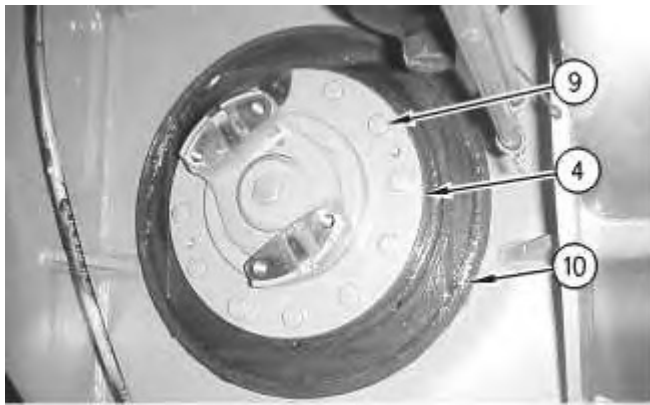

Illustration 7

g00783219

Typical Example

View from the underside of the rear frame.

8. Use two people in order to install bearing carrier (4) and hitch drive shaft (14) to the hitch tube. The weight of bearing carrier (4) and hitch drive shaft (14) is approximately 45 kg (100 lb).
9. Install bolts (9) in order to secure bearing carrier (4) to the hitch tube.  
**Note:** Ensure that the two remaining bolt holes in the bearing carrier are adjacent to each other for installation of the locking plate in step 13.
10. Note the orientation of lip seal (10), and install lip seal (10) onto bearing housing (4).

Thank you so much for reading.  
Please click the “Buy Now!”  
button below to download the  
complete manual.



After you pay.

You can download the most  
perfect and complete manual in  
the world immediately.

Our support email:

[ebooklibonline@outlook.com](mailto:ebooklibonline@outlook.com)