



Service Repair Manual

Models

745C Articulated Truck

Product: ARTICULATED TRUCK

Model: 745C ARTICULATED TRUCK LFK

Configuration: 745C Articulated Truck LFK00001-UP (MACHINE) POWERED BY C18 Engine

Disassembly and Assembly 735C, 740C EJECTOR and 745C Articulated Trucks Power Train

Media Number -UENR4227-04

Publication Date -01/09/2015

Date Updated -02/07/2018

i06530696

Torque Converter - Install

SMCS - 3101-012

Installation Procedure

Table 1

Required Tools			
Tool	Part Number	Part Description	Qty
A	422-5472	Lifting Eye Assembly	2
B	FT-3307	Installation Tool	1

NOTICE

Care must be taken to ensure that fluids are contained during performance of inspection, maintenance, testing, adjusting, and repair of the product. Be prepared to collect the fluid with suitable containers before opening any compartment or disassembling any component containing fluids.

Refer to Special Publication, NENG2500, "Dealer Service Tool Catalog" for tools and supplies suitable to collect and contain fluids on Cat[®] products.

Dispose of all fluids according to local regulations and mandates.

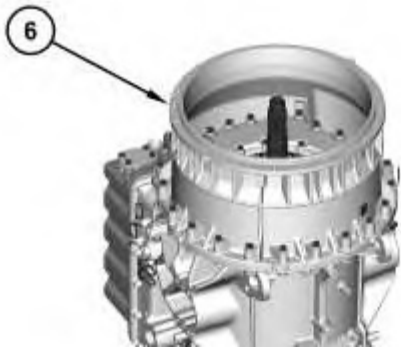

Illustration 1

g03862127

Note: Note the position of the wiring harness clips.

1. If necessary, remove housing (6).

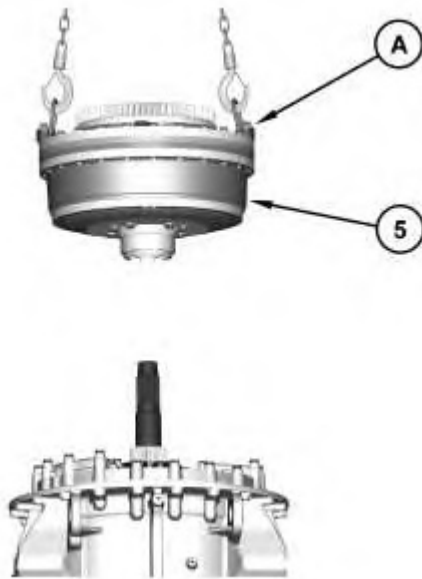

Illustration 2

g03861587

2. Install Tooling (A) and a suitable lifting device to torque converter (5). The weight of torque converter (5) is approximately 95 kg (209 lb).

Note: The torque converter needs to make three spline connections and spin freely to be properly seated.

3. Install torque converter (5) Remove the suitable lifting device and Tooling (A).
-

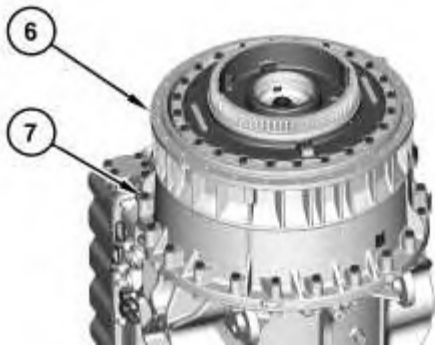

Illustration 3

g03862114

4. Position a new gasket and install housing (6). Install bolts (7) the washers and the clips.



Illustration 4

g03817171

Note: Install a new retaining ring (3) Do not reuse old retaining ring (3).

5. Install plate (4). Install retaining ring (3).

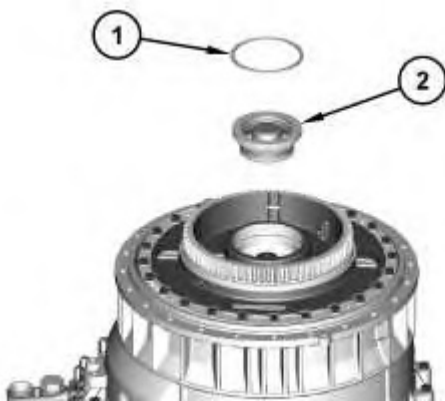

Illustration 5

g03817170

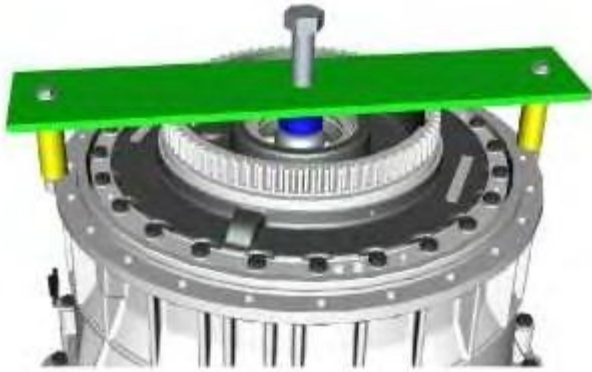

Illustration 6

g06073935

6. Using tooling (A), install the O-ring seals onto pilot (2) and install pilot (2). Install retaining ring (1).

End By:

- a. Install the transmission.

Thank you so much for reading.
Please click the “Buy Now!”
button below to download the
complete manual.



After you pay.

You can download the most
perfect and complete manual in
the world immediately.

Our support email:

ebooklibonline@outlook.com