



Service Repair Manual

Models

745C Articulated Truck

Product: ARTICULATED TRUCK

Model: 745C ARTICULATED TRUCK TFK

Configuration: 745C Articulated Truck TFK00001-UP (MACHINE) POWERED BY C18 Engine

Disassembly and Assembly 735C, 740C EJECTOR and 745C Articulated Trucks Power Train

Media Number -UENR4227-04

Publication Date -01/09/2015

Date Updated -02/07/2018

i07142939

Output Transfer Gears - Disassemble

SMCS - 3159-015-OJ

Disassembly Procedure

Table 1

Required Tooling			
Tool	Part Number	Part Description	Qty
A	1P-2322	Combination Puller	1
B	1H-3107	Push-Puller Tool Gp	1
	5F-7343	Bearing Puller Gp	1
C	1P-0520	Driver Gp	1
D	8T-0644	Bolt ⁽¹⁾	3
E	6V-5696	Bolt	2
F	422-5473	Lifting Eye Assembly	2

⁽¹⁾ Cut off the threaded ends of Bolts (D).

Start By:

- a. Remove the output transfer gears.

NOTICE

Care must be taken to ensure that fluids are contained during performance of inspection, maintenance, testing, adjusting, and repair of the product. Be prepared to collect the fluid with suitable containers

before opening any compartment or disassembling any component containing fluids.

Refer to Special Publication, NENG2500, "Dealer Service Tool Catalog" for tools and supplies suitable to collect and contain fluids on Cat[®] products.

Dispose of all fluids according to local regulations and mandates.



Personal injury or death can result from improper lifting or blocking.

When a hoist or jack is used to lift any part or component, stand clear of the area. Be sure the hoist or jack has the correct capacity to lift a component. Install blocks or stands before performance of any work under a heavy component.

Approximate weights of the components are shown. Clean all surfaces where parts are to be installed.

Note: Exercise caution when you handle the case and the covers for the output transfer gears. The case and the covers are aluminum, therefore more susceptible to damage during handling. Avoid using lifting eyes, chains, and tooling, that directly contact the sealing surfaces.

1. Drain the oil from the output transfer gears into a suitable container.
-

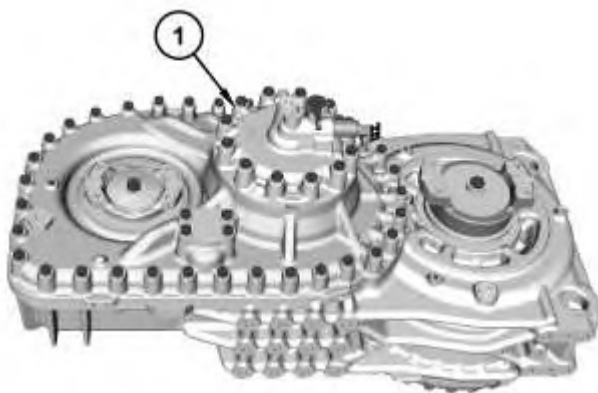

Illustration 1

g03842407

2. Position output transfer gears (1) on suitable cribbing. The weight of output transfer gears (1) is approximately 363 kg (800 lb).
-

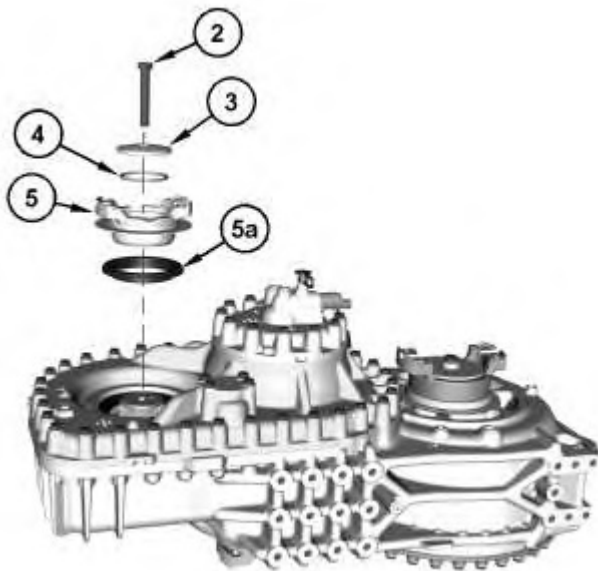

Illustration 2

g06235277

3. Remove bolt (2), retainer plate (3), O-ring seal (4), and yoke (5). Remove wear seal (5a) from yoke (5).

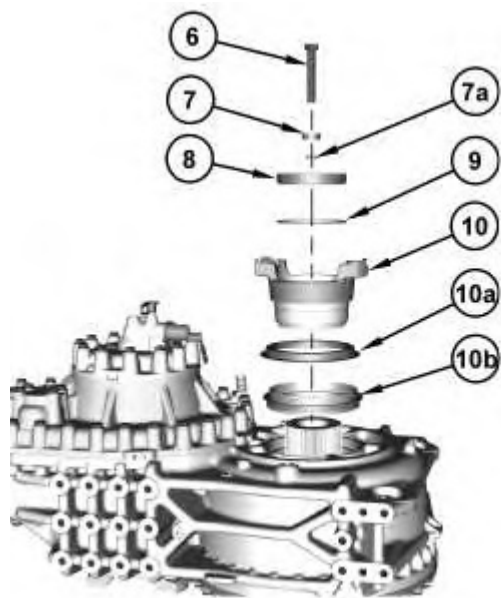

Illustration 3

g03842485

4. Remove bolt (6), washer (7), O-ring seal (7a), plate (8), O-ring seal (9), and yoke (10). Remove wear seal (10a) from yoke (10). Remove lip seal (10b).

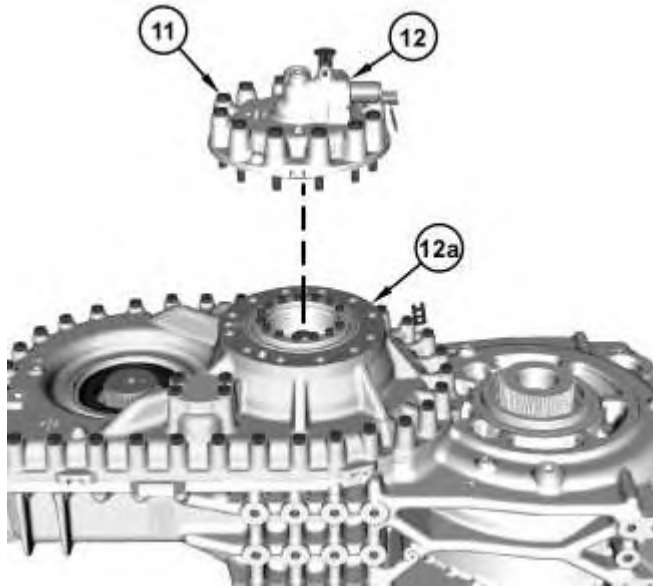

Illustration 4

g03842503

5. Remove bolts (11), manifold (12), and gasket (12a).

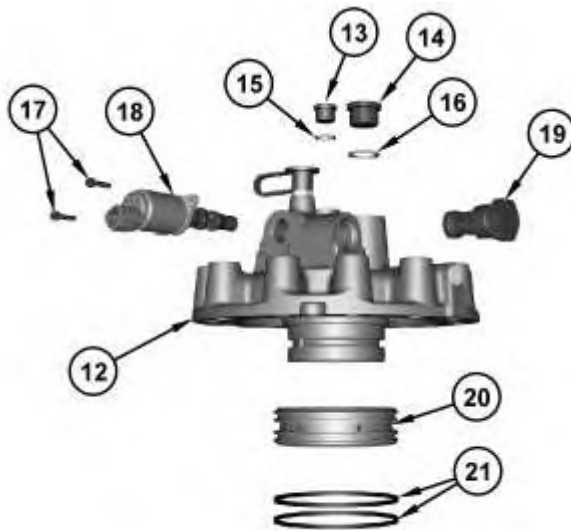

Illustration 5

g03842515

(12) manifold

Note: Do not remove carrier (20) from manifold (12). Carrier (20) is shown only for reference. Carrier (20) is not serviceable.

6. Remove plug (13) and O-ring seal (15). Remove plug (14) and O-ring seal (16).
7. Remove bolts (17), solenoid valve (18), and the O-ring seals. Remove check valve (19) and the O-ring seals.
8. Remove seals rings (21) from carrier (20).

Thank you so much for reading.
Please click the “Buy Now!”
button below to download the
complete manual.



After you pay.

You can download the most
perfect and complete manual in
the world immediately.

Our support email:

ebooklibonline@outlook.com