



Service Repair Manual

Models

903C COMPACT WHEEL LOADER

Product: COMPACT WHEEL LOADER

Model: 903C COMPACT WHEEL LOADER W6T

Configuration: 903C Compact Wheel Loader W6T00001-UP (MACHINE) POWERED BY C2.4 Engine

Disassembly and Assembly

C1.7, C1.8 and C2.4 Tier 4 Interim and EU Stage 3A Engines for Caterpillar Built Machines

Media Number -UENR0128-11

Publication Date -01/08/2015

Date Updated -09/06/2016

i05243152

Fuel Injection Lines - Remove and Install

SMCS - 1252-010

Removal Procedure

NOTICE

Keep all parts clean from contaminants.

Contaminants may cause rapid wear and shortened component life.

NOTICE

Care must be taken to ensure that fluids are contained during performance of inspection, maintenance, testing, adjusting and repair of the product. Be prepared to collect the fluid with suitable containers before opening any compartment or disassembling any component containing fluids.

Dispose of all fluids according to local regulations and mandates.

Note: Place identification marks on all tube assemblies for installation. Plug all lines and tube assemblies in order to prevent contamination.

1. Turn the fuel supply to the OFF position.
-

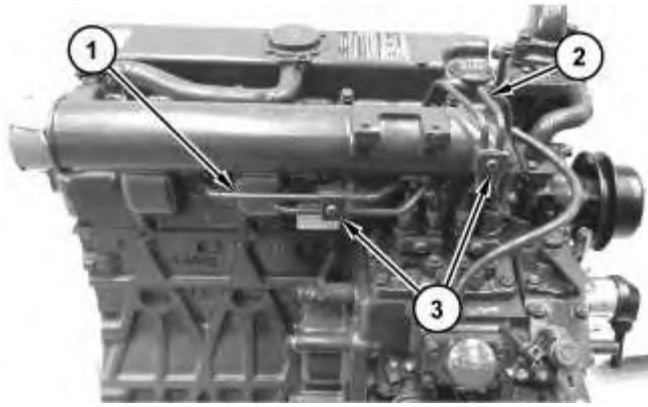

Illustration 1

g02719969

2. If necessary, remove clamp assemblies (3).
3. Remove fuel injection lines (1) and (2) from the engine and the fuel injection pump.
4. Use suitable caps in order to plug the open ports of the fuel injection pump immediately.

Installation Procedure

1. Install fuel injection lines in the reverse order of removal.
 - a. Tighten fuel injection line retaining nut to a torque of 15-24 N·m (11-18 lb ft).

Product: COMPACT WHEEL LOADER

Model: 903C COMPACT WHEEL LOADER W6T

Configuration: 903C Compact Wheel Loader W6T00001-UP (MACHINE) POWERED BY C2.4 Engine

Disassembly and Assembly

C1.7, C1.8 and C2.4 Tier 4 Interim and EU Stage 3A Engines for Caterpillar Built Machines

Media Number -UENR0128-11

Publication Date -01/08/2015

Date Updated -09/06/2016

i05243155

Fuel Injection Nozzles - Remove

SMCS - 1254-011

Removal Procedure

Start By:

- a. Remove the fuel injection lines.

NOTICE

Keep all parts clean from contaminants.

Contaminants may cause rapid wear and shortened component life.

NOTICE

Care must be taken to ensure that fluids are contained during performance of inspection, maintenance, testing, adjusting, and repair of the product. Be prepared to collect the fluid with suitable containers before opening any compartment or disassembling any component containing fluids.

Refer to Special Publication, NENG2500, "Dealer Service Tool Catalog" for tools and supplies suitable to collect and contain fluids on Cat products.

Dispose of all fluids according to local regulations and mandates.

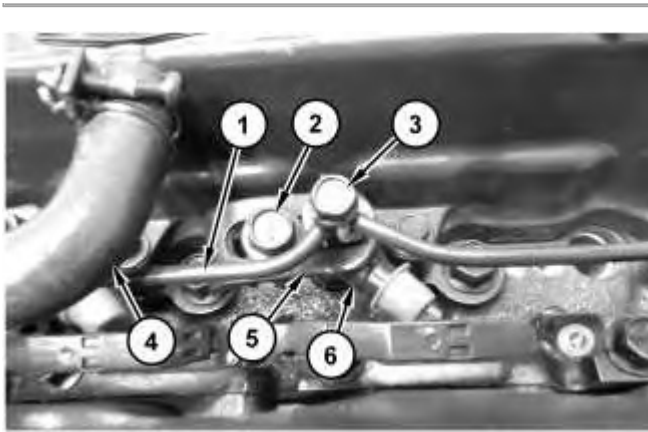

Illustration 1

g02724062

1. If necessary, remove hose assembly (4) and relocate.
2. Remove four bolts (3) and remove tube assembly (1).
3. Remove bolt (2) and hold down clamp (5).
4. Remove fuel injection nozzle (6) from the cylinder head.



Illustration 2

g02724143

5. Remove seat washer (8) from fuel injection nozzle (6). Remove O-ring seal (7). Cap all openings or plug all openings immediately after removal.

Note: Do not reuse seat washer (8) and O-ring seal (7) after removal. Replace the seat washer and the O-ring seal with a new part during installation.

Thank you so much for reading.
Please click the “Buy Now!”
button below to download the
complete manual.



After you pay.

You can download the most
perfect and complete manual in
the world immediately.

Our support email:

ebooklibonline@outlook.com