



Service Repair Manual

Models

930K Wheel Loader

Product: WHEEL LOADER

Model: 930K WHEEL LOADER EYE

Configuration: 930K Small Wheel Loader EYE00001-UP (MACHINE) POWERED BY C7.1 Engine

Disassembly and Assembly 924K, 930K and 938K Wheel Loaders

Media Number -UENR0287-05

Publication Date -01/08/2013

Date Updated -02/11/2017

i04554171

Piston Pump (Steering)

SMCS - 4306; 5070

Removal Procedure

Start By:

- a. Remove the cab.
- b. Remove the hydrostatic, charge gear pump.
1. Refer to Operation and Maintenance Manual, "Hydraulic System Oil - Change" for the correct draining and filling procedures.

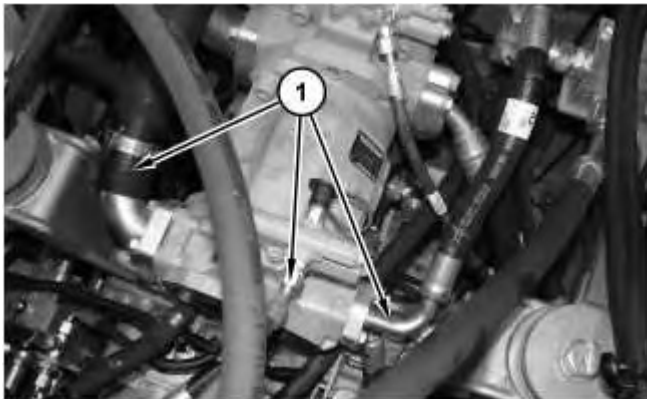

Illustration 1

g02723776

2. Disconnect hose assemblies (1).
-

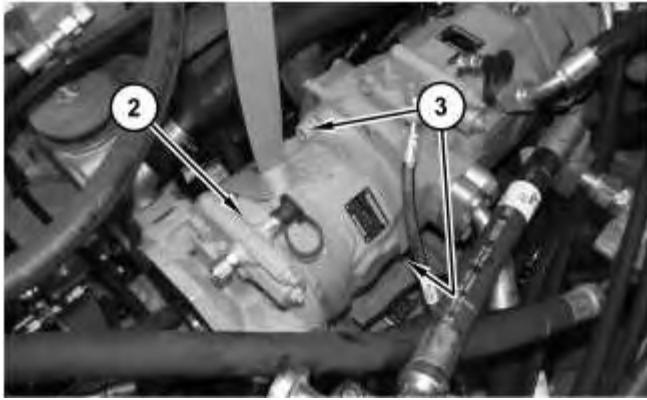

Illustration 2

g02723929

3. Attach a suitable lifting device to steering piston pump (2). The weight of steering piston pump (2) is approximately 36 kg (80 lb). Remove bolts (3). Use the suitable lifting device in order to remove steering piston pump (2).



Illustration 3

g02723958

4. Remove coupling (4).

Installation Procedure

1. Install steering piston pump (2) in the reverse order of removal.
 - a. Tighten bolts (3) to a torque of 215 ± 10 N·m (160 ± 7 lb ft)

Disassembly Procedure

Table 1

Required Tools			
Tool	Part Number	Part Description	Qty
A	9S-9152	Bearing Puller	1
B	1P-0510	Driver Group	1

Start By:

- a. Remove the steering piston pump.

Note: If a failure occurs, an accurate diagnosis of the cause can prevent a recurrence. Information is available to analyze failures for piston pumps and motors. Refer to Special Publication, SEBD0641, "Analyzing Axial Piston Pump and Motor Failures".

Note: Inspect all parts. If any parts are worn or damaged use new parts for replacement. The installation of used parts during reconditioning is acceptable. Reuse and salvage information is available on piston pumps. Refer to Guideline for Reusable Parts and Salvage Operations, SEBF8032, "Piston Pumps and Motors". During reconditioning, correct any conditions that might have caused the original failure.

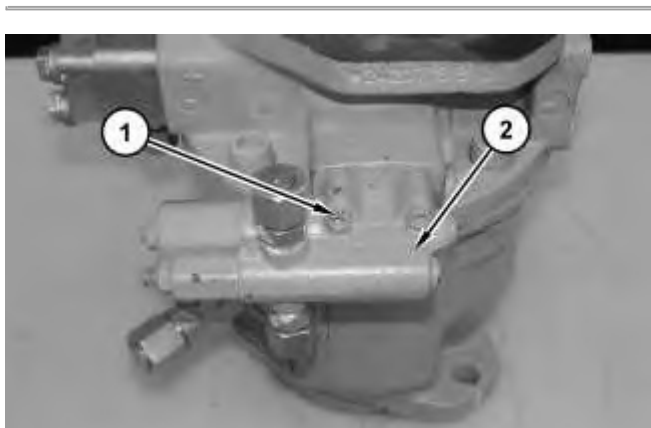

Illustration 4

g01284849

1. Remove bolts (1) and compensator valve (2).

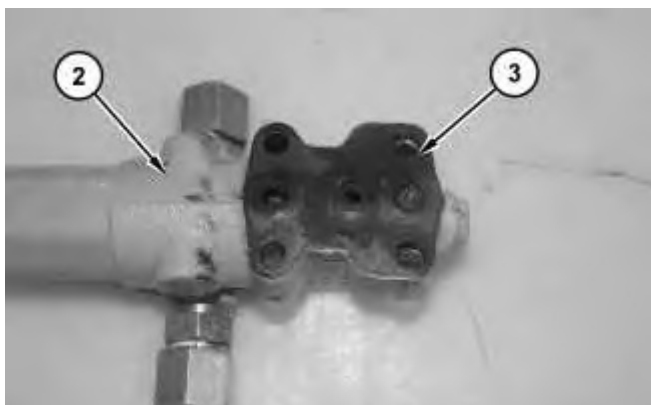

Illustration 5

g01284850

2. Remove gasket (3) from compensator valve (2).
-

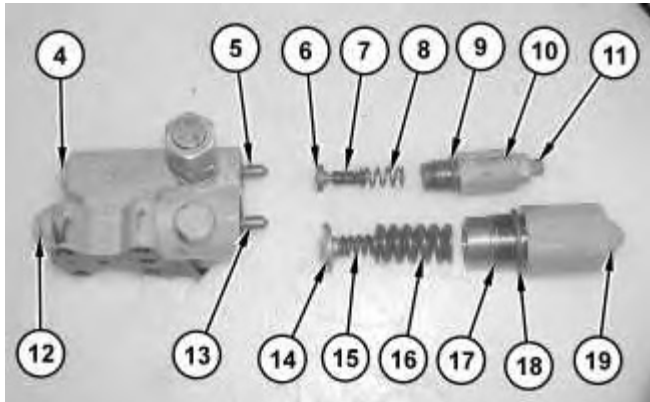

Illustration 6

g01284851

WARNING

Personal injury can result from being struck by parts propelled by a released spring force.

Make sure to wear all necessary protective equipment.

Follow the recommended procedure and use all recommended tooling to release the spring force.

3. Remove plug (4), and the O-ring seal.
4. Remove plug (12), and the O-ring seal.
5. Remove valve (10), spool (5), retainer (6), spring (7), spring (8), O-ring seal (9), and screw assembly (11).
6. Remove valve (17), spool (13), retainer (14), spring (15), spring (16), O-ring seal (18), and screw assembly (19).

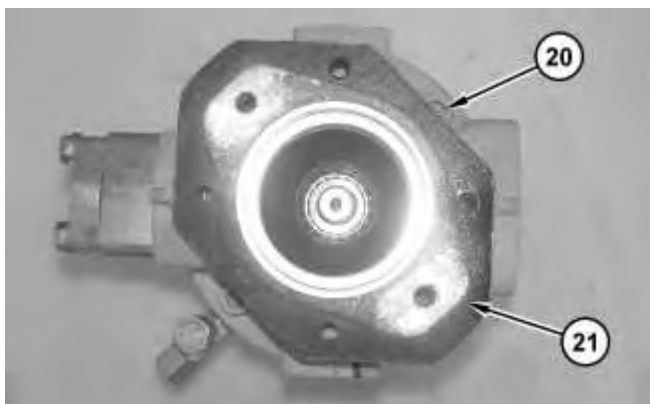

Illustration 7

g01284854

Thank you so much for reading.
Please click the “Buy Now!”
button below to download the
complete manual.



After you pay.

You can download the most
perfect and complete manual in
the world immediately.

Our support email:

ebooklibonline@outlook.com