



# Service Repair Manual

## **Models**

# 950H WHEEL LOADER

---

Product: WHEEL LOADER

Model: 950H WHEEL LOADER M1G

Configuration: 950H Wheel Loader M1G00001-UP (MACHINE) POWERED BY C7 Engine

## Disassembly and Assembly

### IT62H Integrated Toolcarrier and 950H and 962H Wheel Loaders Power Train

Media Number -REN8867-05

Publication Date -01/06/2014

Date Updated -27/06/2014

i02348371

# Torque Converter from Transmission, Output Transfer Gears - Separate

SMCS - 3003-076

## Separation Procedure

Table 1

Required Tools			
Tool	Part Number	Part Description	Qty
A	138-7574	Link Bracket	1
B	138-7573	Link Bracket	3
	1U-9200	Lever Puller Hoist	1

### Start By:

- A. Remove the torque converter, the transmission, and the output transfer gears. Refer to Disassembly and Assembly, "Torque Converter, Transmission and Output Transfer Gears - Remove".

**Note:** Cleanliness is an important factor. Before the disassembly procedure, the exterior of the component should be thoroughly cleaned. This will help to prevent dirt from entering the internal mechanism.

---

## NOTICE

**Care must be taken to ensure that fluids are contained during performance of inspection, maintenance, testing, adjusting and repair of the product. Be prepared to collect the fluid with suitable containers**

**before opening any compartment or disassembling any component containing fluids.**

**Refer to Special Publication, NENG2500, "Caterpillar Tools and Shop Products Guide" for tools and supplies suitable to collect and contain fluids on Caterpillar products.**

**Dispose of all fluids according to local regulations and mandates.**

---

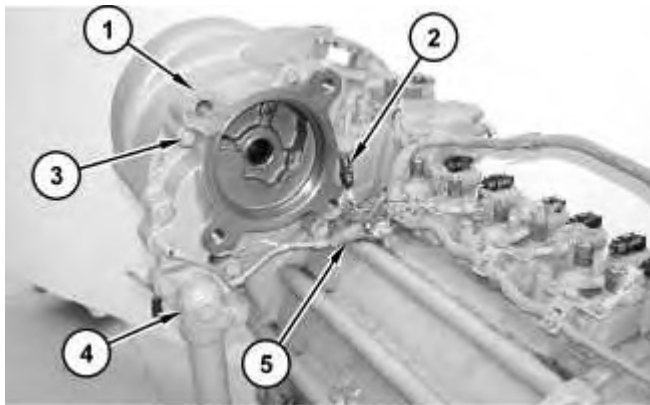

Illustration 1

g01173182

1. Disconnect harness assemblies (2) and (5) .
2. Remove tube assembly (4) .
3. Remove bolts (3) and transmission oil pump (1) .

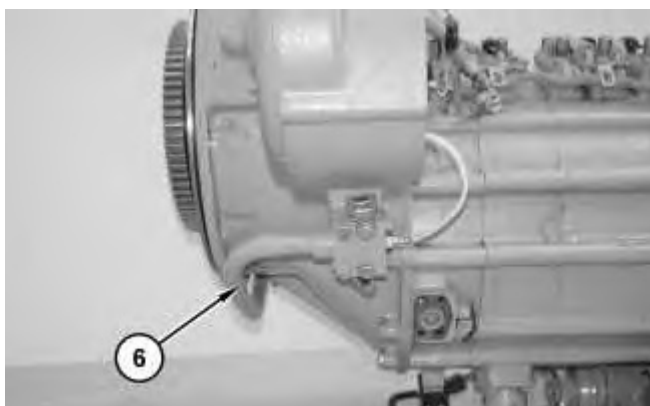

Illustration 2

g01173184

4. Remove tube assembly (6) .

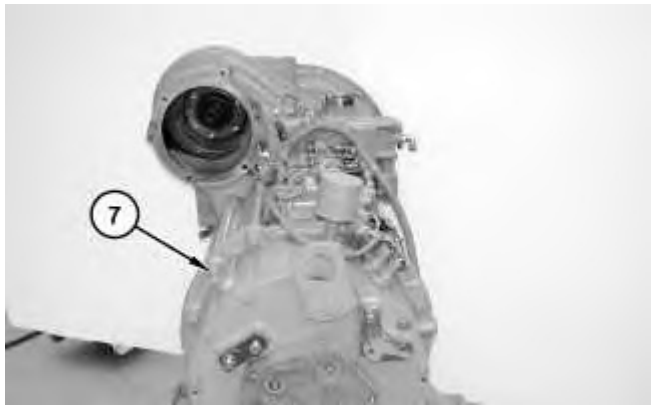

Illustration 3

g01173186

5. Remove bolts (7) .

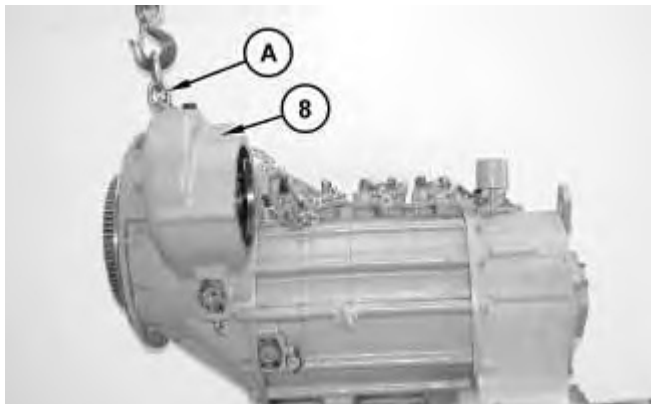

Illustration 4

g01173187

6. Attach Tooling (A) and a suitable lifting device to torque converter (8) .

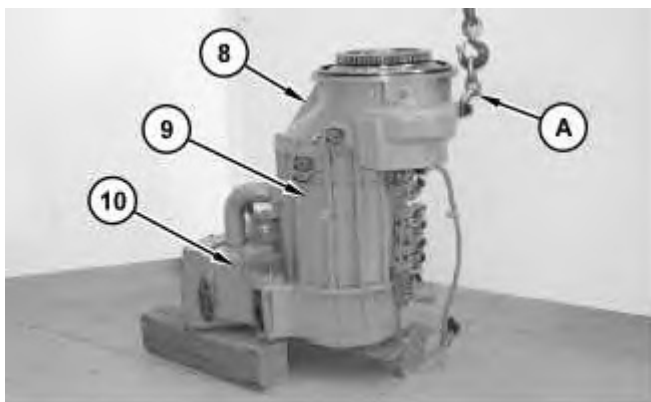

Illustration 5

g01173188

7. Reposition torque converter (8), transmission (9), and output transfer gears (10). The combined weight of torque converter (8), transmission (9), and output transfer gears (10) is approximately 816 kg (1800 lb).
8. Remove Tooling (A) .



Illustration 6

g01173189

9. Attach Tooling (B) and a suitable lifting device to torque converter (8). The weight of torque converter (8) is approximately 170 kg (375 lb).



Illustration 7

g01173190

10. Remove bolts (11) .
-

Thank you so much for reading.  
Please click the “Buy Now!”  
button below to download the  
complete manual.



After you pay.

You can download the most  
perfect and complete manual in  
the world immediately.

Our support email:

[ebooklibonline@outlook.com](mailto:ebooklibonline@outlook.com)