



Service Repair Manual

Models

994K Wheel Loader

Product: WHEEL LOADER

Model: 994K WHEEL LOADER SMX

Configuration: 994K Wheel Loader SMX00001-UP (MACHINE) POWERED BY 3516 Engine

Disassembly and Assembly 3516E Engines for Caterpillar Built Machines

Media Number -M0092351-00

Publication Date -01/06/2018

Date Updated -05/06/2018

i06983441

Cylinder Head - Remove and Install

SMCS - 1100-010; 1101-010

Removal Procedure

Table 1

Required Tools			
Tool	Part Number	Part Description	Qty
A	138-7573	Link Bracket	2

Start By:

- a. Remove the valve cover base.

NOTICE

Keep all parts clean from contaminants.

Contaminants may cause rapid wear and shortened component life.

NOTICE

Do not allow dirt to enter the fuel system. Thoroughly clean the area around a fuel system component that will be disconnected. Fit a suitable cover over any disconnected fuel system components.

NOTICE

Care must be taken to ensure that fluids are contained during performance of inspection, maintenance, testing, adjusting, and repair of the product. Be prepared to collect the fluid with suitable containers before opening any compartment or disassembling any component containing fluids.

Refer to Special Publication, NENG2500, "Dealer Service Tool Catalog" for tools and supplies suitable to collect and contain fluids on Cat® products.

Dispose of all fluids according to local regulations and mandates.

1. Drain the coolant from the cooling system. Refer to Operation and Maintenance Manual, "Cooling System Coolant - Change".

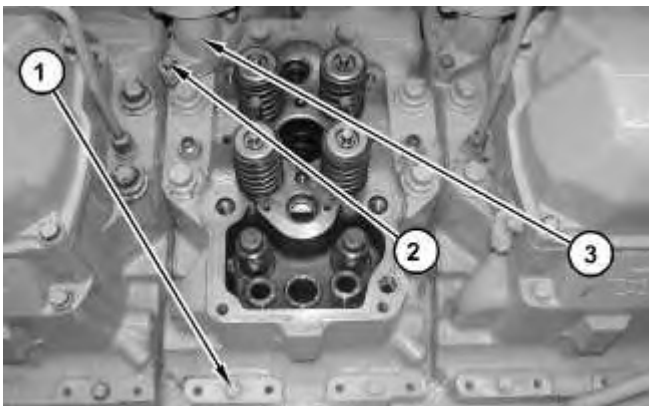

Illustration 1

g01053854

2. Remove bolts (1) and (2). Remove tube (3).

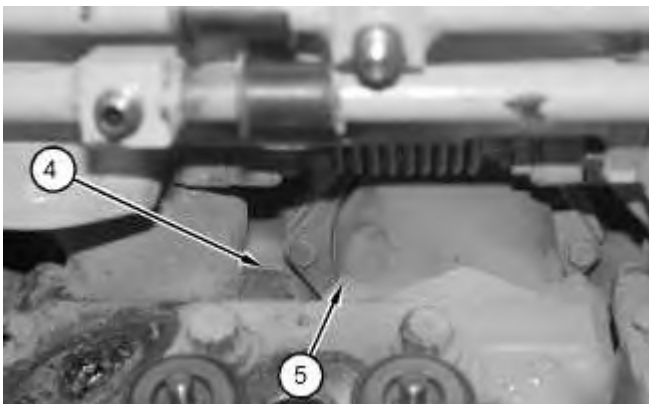

Illustration 2

g01053859

3. Remove four bolts (4) (not shown) from exhaust tube assembly and remove four bolts (5) (not shown) from inlet tube assembly.
-

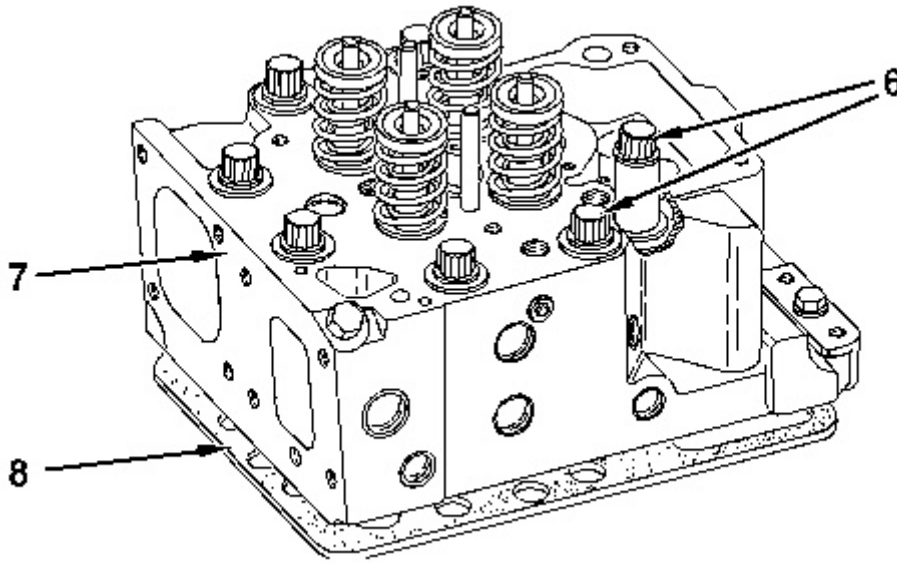

Illustration 3

g01053860

4. Remove bolts (6). Use a suitable lifting device and Tooling (A) to remove cylinder head assembly (7). The weight of cylinder head assembly (7) is approximately 47 kg (104 lb). Remove gasket (8).
-

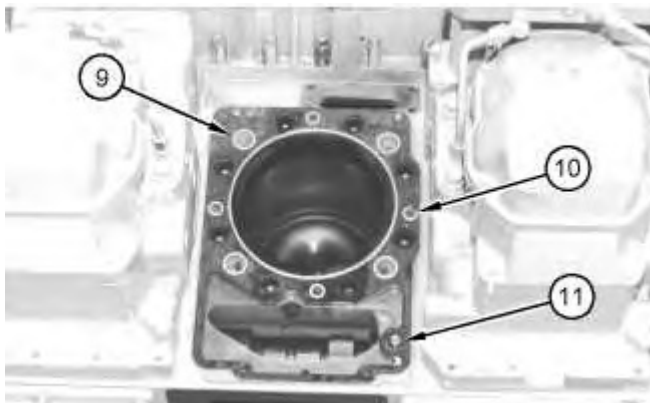

Illustration 4

g01053975

5. Remove seals (9) and (10), and O-ring seal (11) from the spacer plate.
-



Illustration 5

g01053977

6. Remove spacer plate (12) from the dowels in the cylinder block.



Illustration 6

g01053978

7. Remove gasket (13) from the dowels.

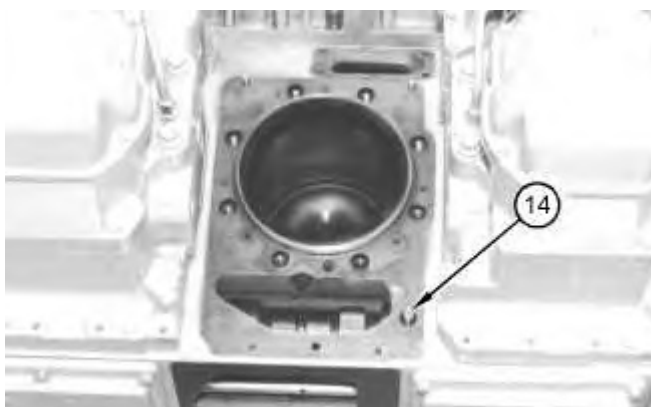

Illustration 7

g01053983

8. Remove the O-ring seal from dowel (14).

Installation Procedure

Thank you so much for reading.
Please click the “Buy Now!”
button below to download the
complete manual.



After you pay.

You can download the most
perfect and complete manual in
the world immediately.

Our support email:

ebooklibonline@outlook.com