



Service Repair Manual

Models

D8L TRACK-TYPE TRACTOR

Product: TRACK-TYPE TRACTOR

Model: D8L TRACK-TYPE TRACTOR 53Y

Configuration: D8L TRACTOR 53Y00001-UP (MACHINE) POWERED BY 3408 ENGINE

Disassembly and Assembly 3408E and 3412E Engines for Caterpillar Built Machines

Media Number -REN2336-06

Publication Date -01/08/2018

Date Updated -10/08/2018

i03335401

Gear Group (Rear) - Remove

SMCS - 1206-011; 1212-011

Removal Procedure

Table 1

Required Tools			
Tool	Part Number	Part Description	Qty
A	1P-0483 ⁽¹⁾	Drive Plate	1
	1U-5839	Bearing Puller	1
B	FT-1342	Guide Bolt	2

⁽¹⁾ Part of the **1P-0510** Driver Group

Start By:

- a. Remove the flywheel housing. Refer to Disassembly and Assembly, "Flywheel Housing - Remove and Install".

NOTICE

Keep all parts clean from contaminants.

Contaminants may cause rapid wear and shortened component life.

Note: There are many possible configurations of the rear gear group and flywheel housing. The following procedure illustrates a typical example.

1. Use the following procedure for disassembly of the adapter assemblies.

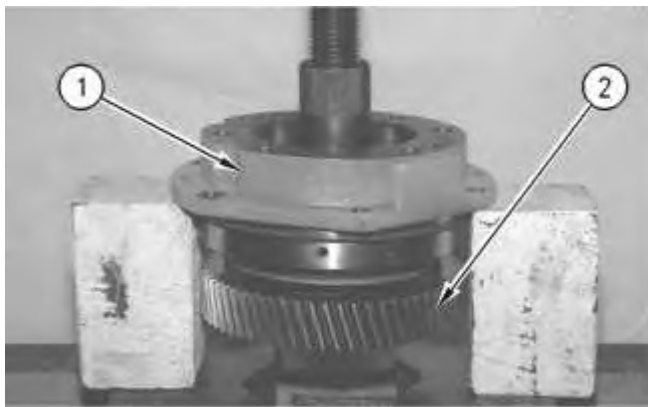

Illustration 1

g00586481

Typical example

- a. Support adapter assembly (1) so that the gear assembly can be pressed out of the adapter assembly. Press gear assembly (2) out of the adapter assembly.



Illustration 2

g00586630

Typical example

- b. Use Tooling (A) in order to remove bearing (3) from the gear assembly.



Illustration 3

g00586904

Typical example

c. Use a press in order to remove bearing (4) from adapter assembly (1).



Illustration 4

g00586907

Typical example

d. Remove bolts (5) and ring (6) from adapter assembly (1).

e. Remove O-ring seal (7) from adapter assembly (1).



Illustration 5

g00586910

Typical example

f. If necessary, remove race (8) from adapter assembly (1).

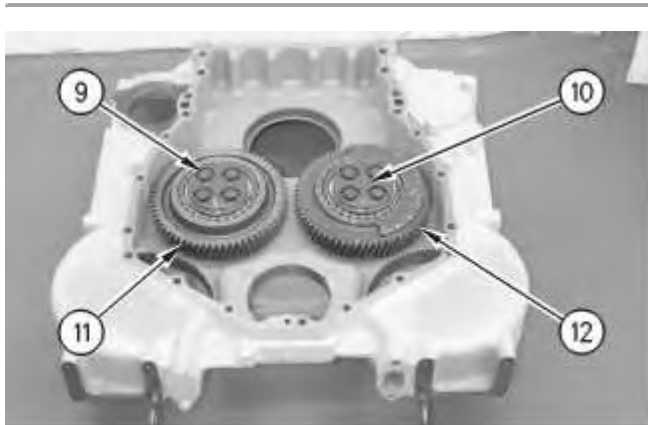

Illustration 6
Typical example

g00587590

2. With the flywheel housing in a horizontal position, remove bolts (9) from shafts (10).

Note: The bearings that are located toward the flywheel will fall when gear (11) and gear (12) are removed. Hold these bearings in position when the gears are removed.

3. Remove balancer gear (12) and idler gear (11).
4. Use the following procedure for disassembly of balancer gear (12).

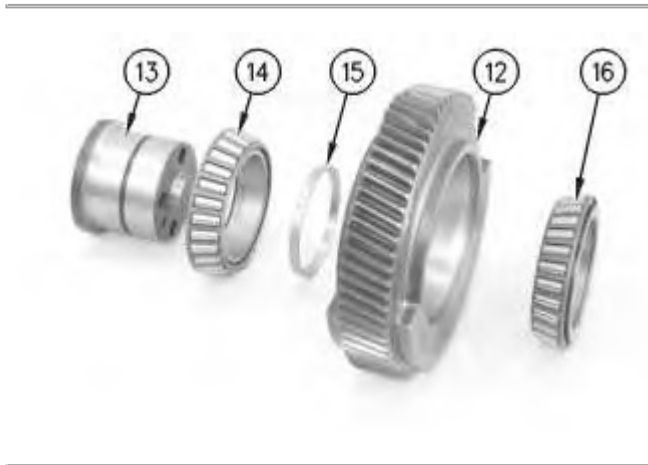

Illustration 7
Typical example

g00587608

- a. Remove shaft (13), spacer (15), bearing (14), and bearing (16) from balancer gear (12).



Illustration 8
Typical example

g00587624

- b. Remove bearing cup (17) from balancer gear (12).

Note: The bearing cups will be damaged from the removal. Use new parts for replacement.

Thank you so much for reading.
Please click the “Buy Now!”
button below to download the
complete manual.



After you pay.

You can download the most
perfect and complete manual in
the world immediately.

Our support email:

ebooklibonline@outlook.com