



Service Repair Manual

Models

M316F Wheeled Excavator

Product: WHEELED EXCAVATOR

Model: M316F WHEELED EXCAVATOR FB6

Configuration: M316F Wheeled Excavator FB600001-UP (MACHINE) POWERED BY C4.4 Engine

Disassembly and Assembly

M314F, M316F, M318F, M320F and M322F Wheeled Excavator Power Train

Media Number -UENR6143-07

Publication Date -01/03/2018

Date Updated -13/03/2018

i06217779

Transmission - Disassemble

SMCS - 3150-015

Disassembly Procedure

Table 1

Required Tools			
Tool	Part Number	Part Description	Qty
A	1P-0074	Slide Hammer Puller Gp	1
	4C-5651	Threaded Adapter	1
B	136-1452	Retaining Ring Pliers As	1
C	5P-5197	Retaining Ring Pliers As	1
D	1P-1863	Retaining Ring Pliers	1
E	5F-7465	Puller Gp	1
F	6V-3010	Puller Gp	1
	8B-7557	Threaded Adapter	2
	126-7177	Puller Leg	2
	126-7181	Sliding Plate	4
G	8H-0663	Bearing Puller Gp	1
H	9U-7289	Scale	1

Start By:

- a. Remove the transmission.

NOTICE

Care must be taken to ensure that fluids are contained during performance of inspection, maintenance, testing, adjusting, and repair of the product. Be prepared to collect the fluid with suitable containers before opening any compartment or disassembling any component containing fluids.

Refer to Special Publication, NENG2500, "Dealer Service Tool Catalog" for tools and supplies suitable to collect and contain fluids on Cat products.

Dispose of all fluids according to local regulations and mandates.

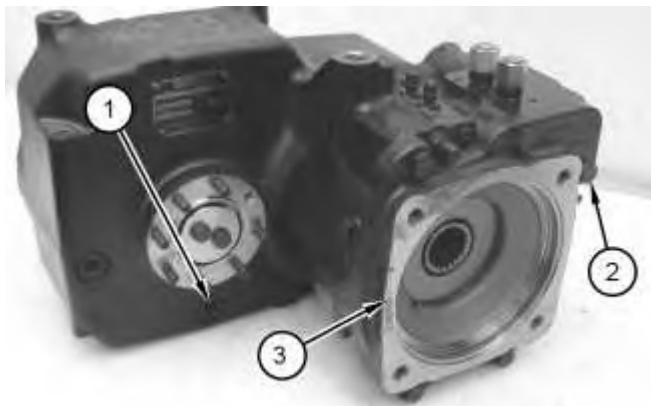

Illustration 1

g01136987

WARNING

Personal injury can result from being struck by parts propelled by a released spring force.

Make sure to wear all necessary protective equipment.

Follow the recommended procedure and use all recommended tooling to release the spring force.

1. Remove plug (1) in order to drain the oil from the transmission into a suitable container. Evenly remove bolts (2) and remove housing (3).
-



Illustration 2

g01136993

2. Remove seal (4) from housing (3).

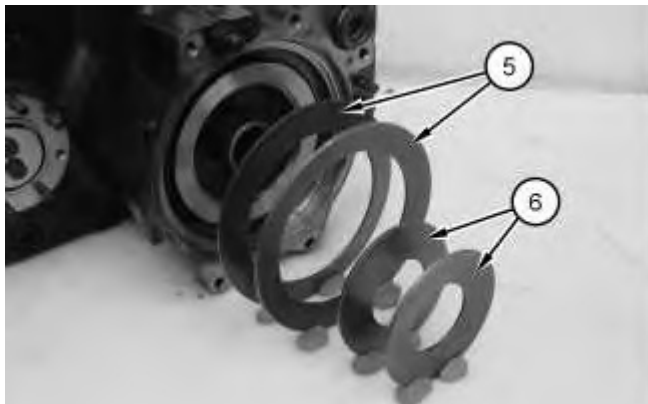

Illustration 3

g01136995

3. Remove springs (5) and (6).

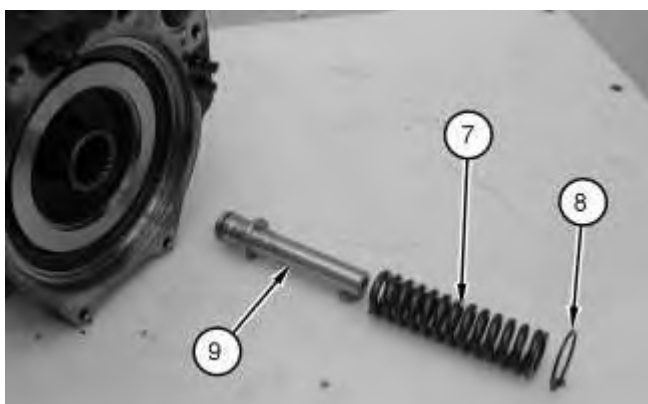

Illustration 4

g01137000

4. Remove spring (7), O-ring seal (8), and spool (9).

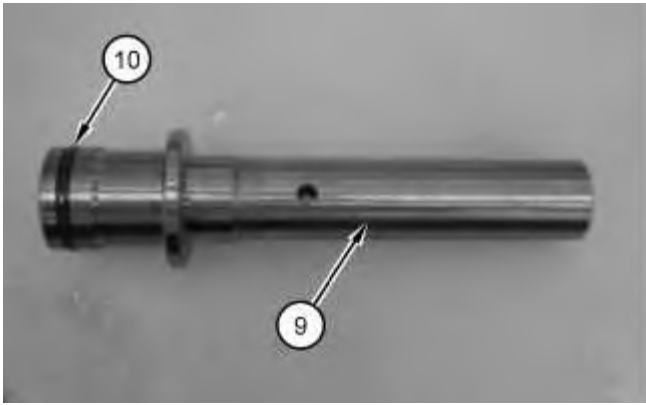

Illustration 5

g01137027

5. Remove seal (10) from spool (9).

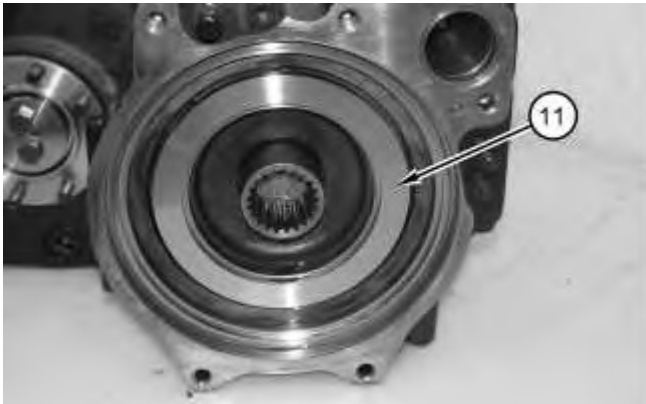

Illustration 6

g01137040

6. Remove piston (11).

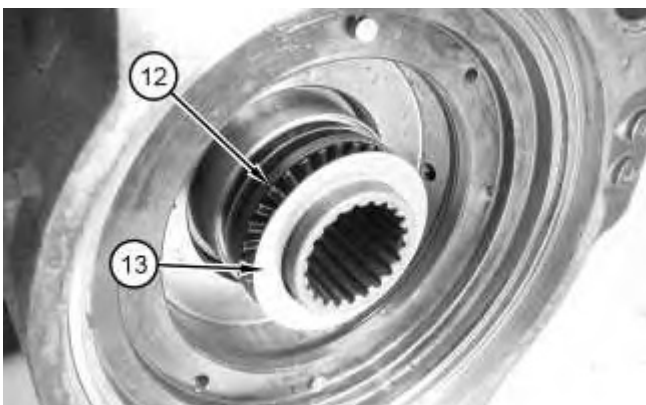

Illustration 7

g01150446

7. Remove race (13) and thrust bearing (12).

Thank you so much for reading.
Please click the “Buy Now!”
button below to download the
complete manual.



After you pay.

You can download the most
perfect and complete manual in
the world immediately.

Our support email:

ebooklibonline@outlook.com