



# Service Repair Manual

## **Models**

# M318D Wheeled Excavator

---

Product: WHEELED EXCAVATOR

Model: M318D WHEELED EXCAVATOR W8P

Configuration: M318D Excavator W8P00001-UP (MACHINE) POWERED BY C6.6 Engine

## Disassembly and Assembly C6.6 Engines for Caterpillar Built Machines

Media Number -KENR6081-15

Publication Date -01/03/2014

Date Updated -04/03/2014

i05735237

### Idler Gear - Remove

SMCS - 1206-011

### Removal Procedure (Standard Idler Gear)

Table 1

Required Tools			
Tool	Part Number	Part Description	Qty
A	230-6284	Timing Pin (Camshaft)	1
B	136-4632	Timing Pin (Crankshaft)	1
	268-1966	Adapter	1

#### Start By:

- a. Remove the fuel injection pump gear. Refer to Disassembly and Assembly, "Fuel Pump Gear - Remove" for the correct procedure.
- b. Remove the valve mechanism cover. Refer to Disassembly and Assembly, "Valve Mechanism Cover - Remove and Install" for the correct procedure.

**Note:** Care must be taken in order to ensure that the fuel injection pump timing is not lost during the removal of the fuel pump gear. Carefully follow the procedure in order to remove the fuel pump gear.

---

#### NOTICE

**Keep all parts clean from contaminants.**

**Contaminants may cause rapid wear and shortened component life.**

---

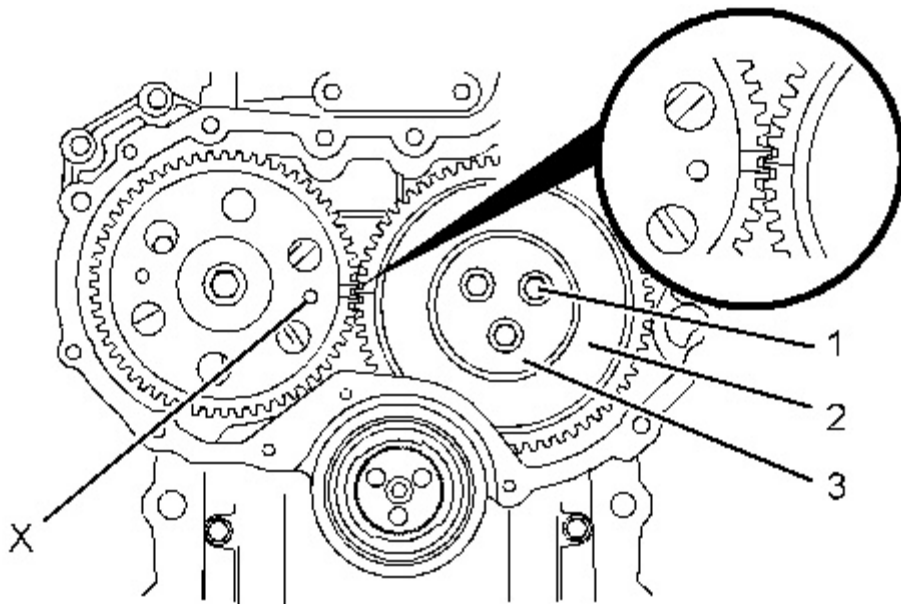

Illustration 1

g01337918

Alignment of timing marks

1. Ensure that Tooling (A) is installed into Hole (X) in the camshaft gear. Use Tooling (A) in order to lock the camshaft in the correct position.

**Note:** Ensure that the gears are marked in order to show alignment. Refer to Illustration 1.

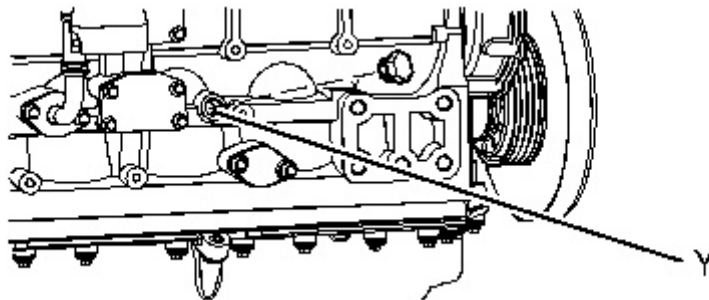

Illustration 2

g01337919

2. Ensure that Tooling (B) is installed in Hole (Y) in the cylinder block. Use Tooling (B) in order to lock the crankshaft in the correct position.
-

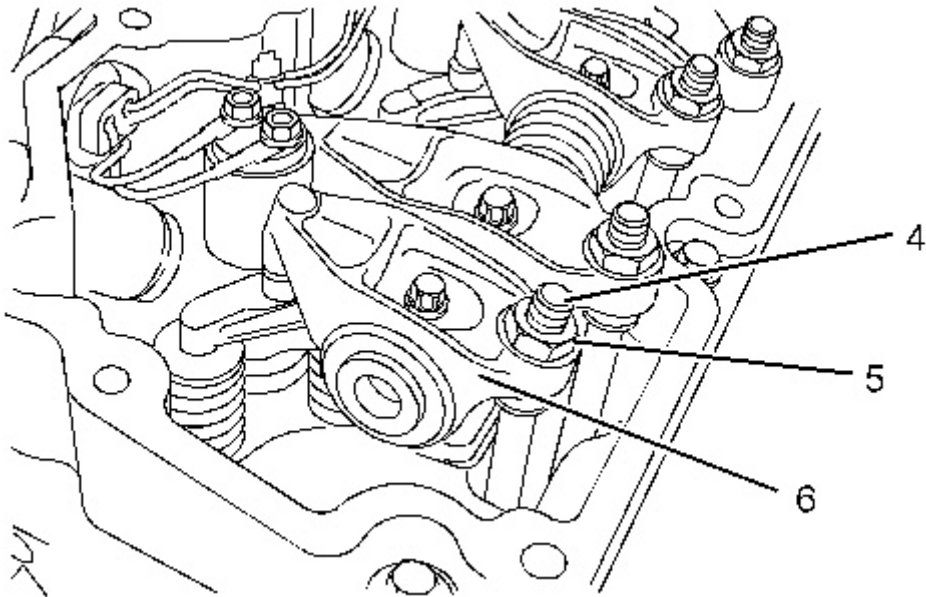

Illustration 3

g01337921

3. Loosen nuts (5) on all rocker arms (6). Unscrew adjusters (4) on all rocker arms (6) until all valves are fully closed.

**Note:** Failure to ensure that ALL adjusters are fully unscrewed can result in contact between the valves and pistons.

4. Mark plate (3) in order to show orientation.

**Note:** Identification will ensure that the plate can be installed in the original orientation.

5. Remove bolts (1).

6. Remove plate (3).

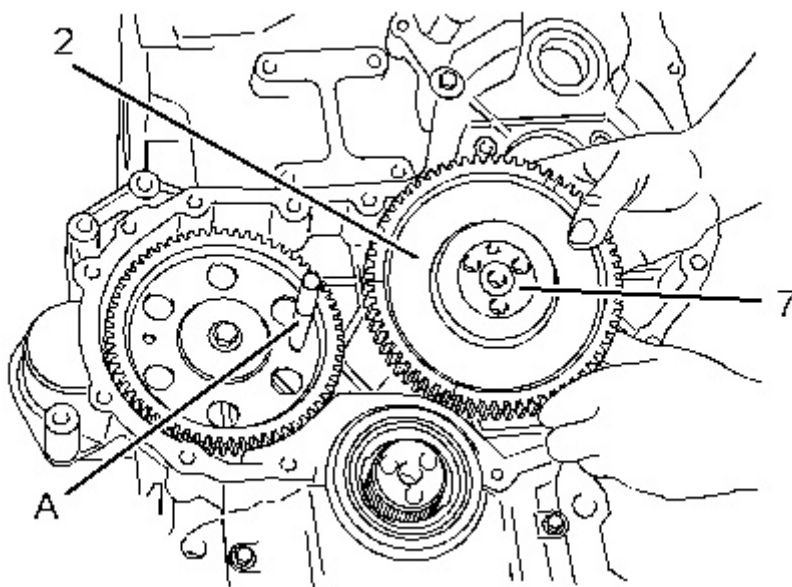

Illustration 4

g01337922

7. Remove the assembly of idler gear (2) and hub (7) from the recess in the front housing.

**Note:** The idler gear must be tilted during removal.

8. Remove hub (7) from idler gear (2).

## Removal Procedure (Early Heavy-Duty Idler Gear)

Table 2

Required Tools			
Tool	Part Number	Part Description	Qty
A	230-6284	Timing Pin (Camshaft)	1
B	136-4632	Timing Pin (Crankshaft)	1
	268-1966	Adapter	1

### Start By:

- a. Remove the fuel injection pump gear. Refer to Disassembly and Assembly, "Fuel Pump Gear - Remove" for the correct procedure.
- b. Remove the valve mechanism cover. Refer to Disassembly and Assembly, "Valve Mechanism Cover - Remove and Install" for the correct procedure.

**Note:** Care must be taken in order to ensure that the fuel injection pump timing is not lost during the removal of the fuel pump gear. Carefully follow the procedure in order to remove the fuel pump gear.

---

### NOTICE

**Keep all parts clean from contaminants.**

**Contaminants may cause rapid wear and shortened component life.**

---

**Note:** The assembly of heavy-duty idler gear is not serviceable. Do not disassemble the heavy-duty idler gear.

---

Thank you so much for reading.  
Please click the “Buy Now!”  
button below to download the  
complete manual.



After you pay.

You can download the most  
perfect and complete manual in  
the world immediately.

Our support email:

[ebooklibonline@outlook.com](mailto:ebooklibonline@outlook.com)