



# Service Repair Manual

## **Models**

M322F Wheeled Excavator

---

Product: WHEELED EXCAVATOR

Model: M322F WHEELED EXCAVATOR F2Z

Configuration: M322F Wheeled Excavator F2Z00001-UP (MACHINE) POWERED BY C7.1 Engine

## Disassembly and Assembly C7.1 Engines for Caterpillar Built Machines

Media Number -UENR4468-15

Publication Date -01/06/2015

Date Updated -30/10/2018

i06799526

# Crankshaft Front Seal - Remove and Install

SMCS - 1160-010

## Removal Procedure

Table 1

Required Tools			
Tool	Part Number	Part Description	Qty
A	367-3534	Oil Seal Removal & Installer Tool	1
B	207-1601	P-80 Rubber Lubricant	1

### Start By:

- a. Remove the crankshaft vibration damper and pulley.

---

### NOTICE

**Keep all parts clean from contaminants.**

**Contaminants may cause rapid wear and shortened component life.**

---

---

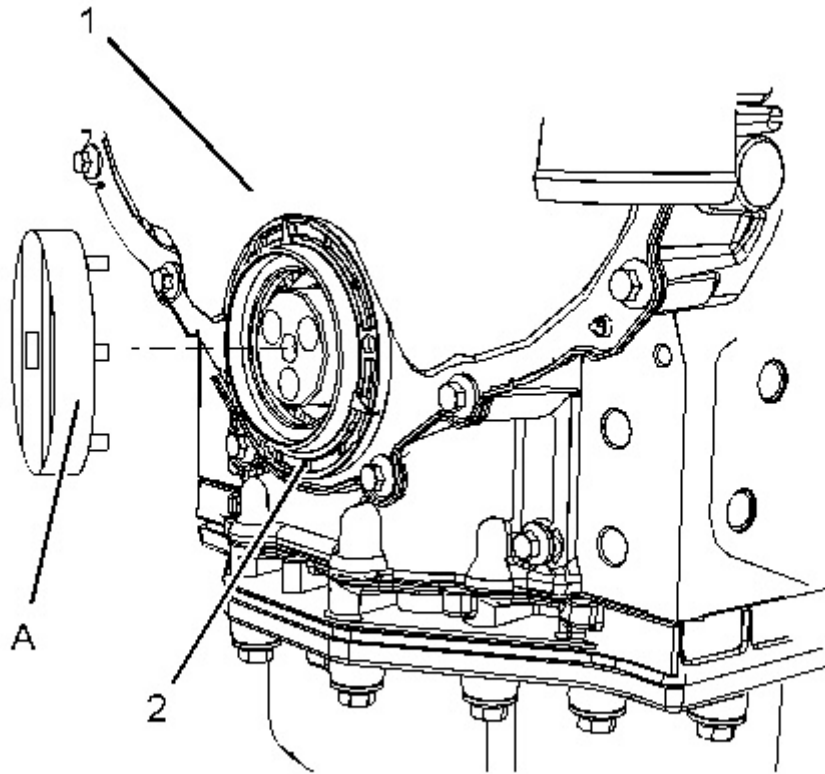

---

Illustration 1

g03417118

1. Position Tooling (A) onto crankshaft front seal (2).
2. Turn Tooling (A) in a counterclockwise direction and remove crankshaft front seal (2) from front cover (1).

## Installation Procedure

1. Ensure that the front cover is clean and free from damage.
-

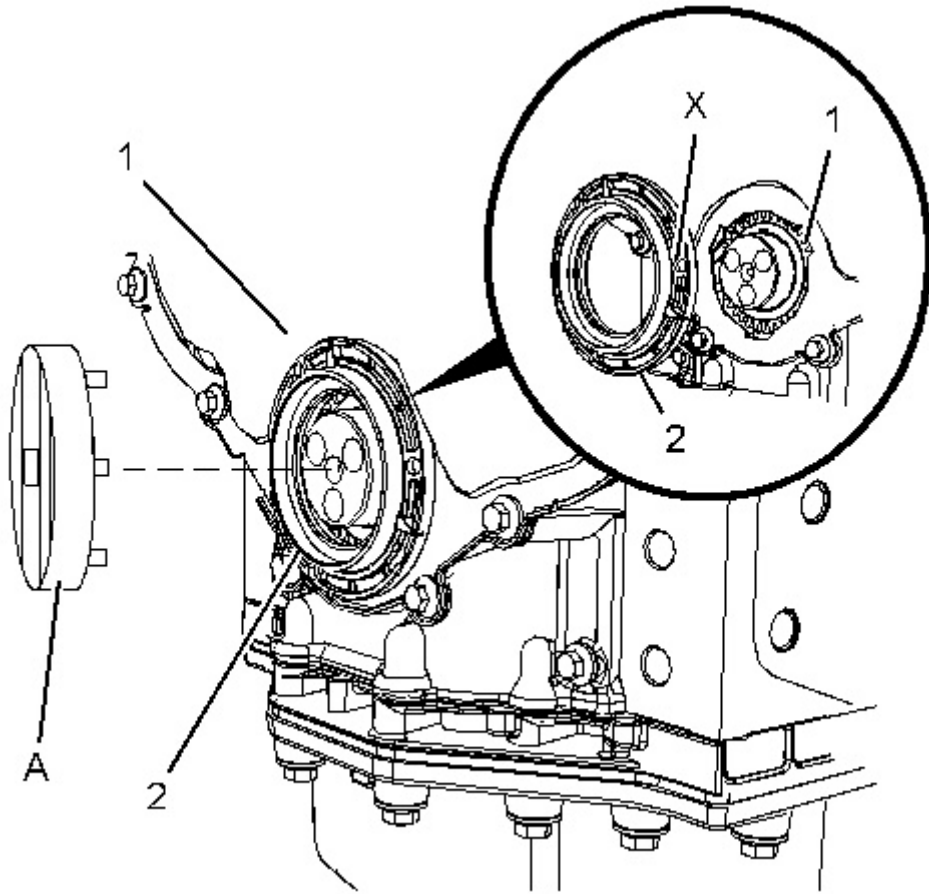

---

Illustration 2

g03417120

---

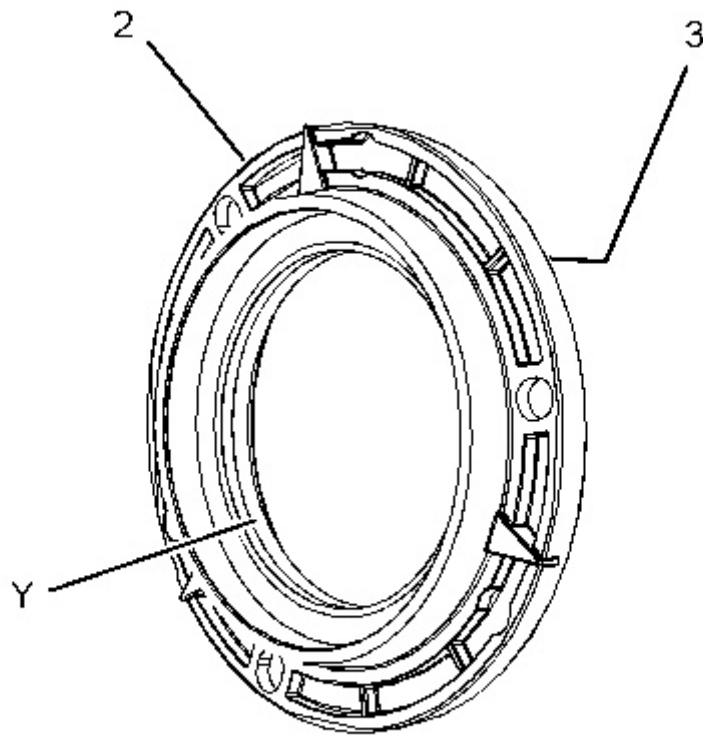

---

Illustration 3

g03453516

2. Apply Tooling (B) to static twin dead seal (3) (not shown) to a new crankshaft front seal (2). Ensure that none of Tooling (B) contaminates the crankshaft front seal in Position (Y).
3. Correctly position a new crankshaft front seal (2) in Position (X) onto front cover (1).
4. Position Tooling (A) onto crankshaft front seal (2).
5. Use Tooling (A) to turn crankshaft front seal (2) in a clockwise direction.
6. If a torque that is greater than 50 N·m (37 lb ft) is necessary to install crankshaft front seal (2), remove crankshaft front seal (2). Inspect crankshaft front seal (2) and front cover (1) for faults or damage.
7. If necessary, repeat Step 2 through Step 6 to install crankshaft front seal (2).

**End By:**

- a. Install the crankshaft vibration damper and pulley.

Thank you so much for reading.  
Please click the “Buy Now!”  
button below to download the  
complete manual.



After you pay.

You can download the most  
perfect and complete manual in  
the world immediately.

Our support email:

[ebooklibonline@outlook.com](mailto:ebooklibonline@outlook.com)