

Groundhog 6x4

[Section 1 - General Information](#)

[Section 2 - Care and Safety](#)

[Section 3 - Routine Maintenance](#)

[Section A - Optional Equipment](#)

[Section B - Body and Framework](#)

[Section C - Electrics](#)

[Section D - Controls](#)

[Section E - Hydraulics](#)

[Section F - Transmission](#)

[Section G - Brakes](#)

[Section H - Steering](#)

[Section K - Engine](#)

[Section S - Suspension](#)



Publication No.
9803-9390-2



Copyright © 2004 JCB SERVICE. All rights reserved. No part of this publication may be reproduced, stored in a retrieval system, or transmitted in any form or by any other means, electronic, mechanical, photocopying or otherwise, without prior permission from JCB SERVICE.

General Information

[Section 1 - General Information](#)

[Section 2 - Care and Safety](#)

[Section 3 - Routine Maintenance](#)

[Section A - Optional Equipment](#)

[Section B - Body and Framework](#)

[Section C - Electrics](#)

[Section D - Controls](#)

[Section E - Hydraulics](#)

[Section F - Transmission](#)

[Section G - Brakes](#)

[Section H - Steering](#)

[Section K - Engine](#)

[Section S - Suspension](#)



Publication No.
9803-9390-2



Copyright © 2004 JCB SERVICE. All rights reserved. No part of this publication may be reproduced, stored in a retrieval system, or transmitted in any form or by any other means, electronic, mechanical, photocopying or otherwise, without prior permission from JCB SERVICE.



Section 1 - General Information

Notes:



Section 1 - General Information

Contents	Page No.
Introduction	
About this Publication	1-1
Machine Identification	
Identifying Your Machine	1-3
Torque Settings	
Zinc Plated Fasteners and Dacromet Fasteners	1-5
Hydraulic Connections	1-9
Service Tools	
Numerical List	1-13
Consumables	
Sealing and Retaining Compounds	1-15



Section 1 - General Information

Contents

Page No.

Introduction

About this Publication

This publication is designed for the benefit of JCB Distributor Service Engineers who are receiving, or have received, training by JCB Technical Training Department.

These personnel should have a sound knowledge of workshop practice, safety procedures, and general techniques associated with the maintenance and repair of hydraulic earthmoving equipment.

Renewal of oil seals, gaskets, etc., and any component showing obvious signs of wear or damage is expected as a matter of course. It is expected that components will be cleaned and lubricated where appropriate, and that any opened hose or pipe connections will be blanked to prevent excessive loss of hydraulic fluid and ingress of dirt. Finally, please remember above all else **SAFETY MUST COME FIRST!**

The manual is compiled in sections, the first three are numbered and contain information as follows:

- 1 General Information - includes torque settings and service tools.
- 2 Care & Safety - includes warnings and cautions pertinent to aspects of workshop procedures etc.
- 3 Routine Maintenance - includes service schedules and recommended lubricants for all the machine.

The remaining sections are alphabetically coded and deal with Dismantling, Overhaul etc. of specific components, for example:

- A** Attachments
- B** Body and Framework...etc.

Section contents, technical data, circuit descriptions, operation descriptions etc. are inserted at the beginning of each alphabetically coded section.

All sections are listed on the front cover; tabbed divider cards align directly with individual sections on the front cover for rapid reference.

Where a torque setting is given as a single figure it may be varied by plus or minus 3%. Torque figures indicated are for dry threads, hence for lubricated threads may be reduced by one third.

'Left Hand' and 'Right Hand' are as viewed from the rear of the machine facing forwards.



Section 1 - General Information

Introduction

About this Publication

Page left intentionally blank

Machine Identification

Identifying Your Machine

The machine has a Data Plate 1-X attached to the rear of the machine.

The serial numbers of the machine, engine and gearbox are stamped on this plate.

If the engine is replaced, stamp the new serial number in place of the old one

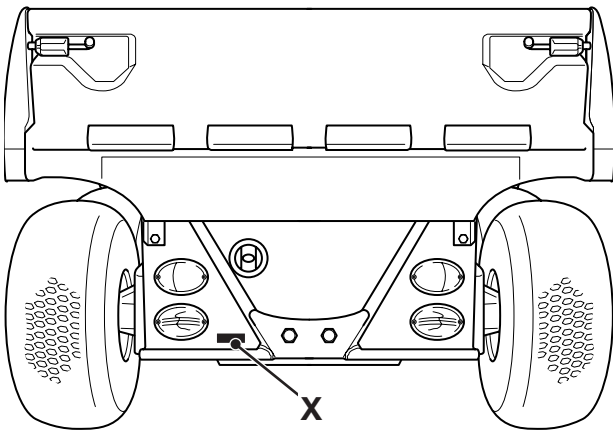

Fig 1.

Typical Vehicle Identification Number (VIN)

SLP	800	2	E	M10060000
1	2	3	4	5

- 1 World Manufacturer Identification
- 2 Machine Model
- 3 Year of Manufacture:
 - 4 = 2004
 - 5 = 2005
 - 6 = 2006
 - 7 = 2007
- 4 Manufacturer Location (E = England)
- 5 Machine Serial Number

Explanation of Engine Identification Number

Code	A	B	C	D	E
Example	KD	50316	J	000001	2

- A Engine Type
- B Engine Parts List
- C Country of Manufacture
- D Engine Serial Number
- E Year of Manufacture

Torque Settings

Zinc Plated Fasteners and Dacromet Fasteners

T11-002

Introduction

Some external fasteners on JCB machines are manufactured using an improved type of corrosion resistant finish. This type of finish is called Dacromet and replaces the original Zinc and Yellow Plating used on earlier machines.

The two types of fasteners can be readily identified by colour and part number suffix. ⇒ [Table 1. Fastener Types](#) (1-5).

Table 1. Fastener Types

Fastener Type	Colour	Part No. Suffix
Zinc and Yellow	Golden finish	'Z' (e.g. 1315/3712Z)
Dacromet	Mottled silver finish	'D' (e.g. 1315/3712D)

Note: As the Dacromet fasteners have a lower torque setting than the Zinc and Yellow fasteners, the torque figures used must be relevant to the type of fastener.

Note: A Dacromet bolt should not be used in conjunction with a Zinc or Yellow plated nut, as this could change the torque characteristics of the torque setting further. For the same reason, a Dacromet nut should not be used with a Zinc or Yellow plated bolt.

Note: All bolts used on JCB machines are high tensile and must not be replaced by bolts of a lesser tensile specification.

Note: Dacromet bolts, due to their high corrosion resistance are used in areas where rust could occur. Dacromet bolts are only used for external applications. They are not used in applications such as gearbox or engine joint seams or internal applications.

Bolts and Screws

Use the following torque setting tables only where no torque setting is specified in the text.

Note: Dacromet fasteners are lubricated as part of the plating process, do not lubricate.

Torque settings are given for the following conditions:

Condition 1

- Un-lubricated fasteners
- Zinc fasteners
- Yellow plated fasteners

Condition 2

- Zinc flake (Dacromet) fasteners
- Lubricated zinc and yellow plated fasteners
- Where there is a natural lubrication. For example, cast iron components

Verbus Ripp Bolts

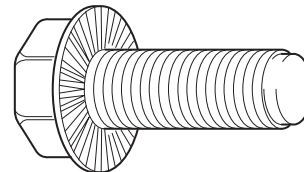

Fig 2.

Torque settings for these bolts are determined by the application. Refer to the relevant procedure for the required settings.



Section 1 - General Information Torque Settings

Zinc Plated Fasteners and Dacromet Fasteners

Table 2. Torque Settings - UNF Grade 'S' Fasteners

Bolt Size		Hexagon (A/F)	Condition 1			Condition 2		
in.	mm	in.	Nm	kgf m	lbf ft	Nm	kgf m	lbf ft
1/4	6.3	7/16	11.2	1.1	8.3	10.0	1.0	7.4
5/16	7.9	1/2	22.3	2.3	16.4	20.0	2.0	14.7
3/8	9.5	9/16	40.0	4.1	29.5	36.0	3.7	26.5
7/16	11.1	5/8	64.0	6.5	47.2	57.0	5.8	42.0
1/2	12.7	3/4	98.0	10.0	72.3	88.0	9.0	64.9
9/16	14.3	13/16	140.0	14.3	103.2	126.0	12.8	92.9
5/8	15.9	15/16	196.0	20.0	144.6	177.0	18.0	130.5
3/4	19.0	1 1/8	343.0	35.0	253.0	309.0	31.5	227.9
7/8	22.2	1 15/16	547.0	55.8	403.4	492.0	50.2	362.9
1	25.4	1 1/2	814.0	83.0	600.4	732.0	74.6	539.9
1 1/8	31.7	1 7/8	1181.0	120.4	871.1	1063.0	108.4	784.0
1 1/4	38.1	2 1/4	1646.0	167.8	1214.0	1481.0	151.0	1092.3

Table 3. Torque Settings - Metric Grade 8.8 Fasteners

Bolt Size		Hexagon (A/F)	Condition 1			Condition 2		
ISO Metric Thread	mm	mm	Nm	kgf m	lbf ft	Nm	kgf m	lbf ft
M5	5	8	5.8	0.6	4.3	5.2	0.5	3.8
M6	6	10	9.9	1.0	7.3	9.0	0.9	6.6
M8	8	13	24.0	2.4	17.7	22.0	2.2	16.2
M10	10	17	47.0	4.8	34.7	43.0	4.4	31.7
M12	12	19	83.0	8.5	61.2	74.0	7.5	54.6
M16	16	24	205.0	20.9	151.2	184.0	18.8	135.7
M20	20	30	400.0	40.8	295.0	360.0	36.7	265.5
M24	24	36	690.0	70.4	508.9	621.0	63.3	458.0
M30	30	46	1372.0	139.9	1011.9	1235.0	125.9	910.9
M36	36	55	2399.0	244.6	1769.4	2159.0	220.0	1592.4



Section 1 - General Information Torque Settings

Zinc Plated Fasteners and Dacromet Fasteners

Table 4. Metric Grade 10.9 Fasteners

Bolt Size		Hexagon (A/F)	Condition 1			Condition 2		
ISO Metric Thread	mm	mm	Nm	kgf m	lbf ft	Nm	kgf m	lbf ft
M5	5	8	8.1	0.8	6.0	7.3	0.7	5.4
M6	6	10	13.9	1.4	10.2	12.5	1.3	9.2
M8	8	13	34.0	3.5	25.0	30.0	3.0	22.1
M10	10	17	67.0	6.8	49.4	60.0	6.1	44.2
M12	12	19	116.0	11.8	85.5	104.0	10.6	76.7
M16	16	24	288.0	29.4	212.4	259.0	26.4	191.0
M20	20	30	562.0	57.3	414.5	506.0	51.6	373.2
M24	24	36	971.0	99.0	716.9	874.0	89.1	644.6
M30	30	46	1930.0	196.8	1423.5	1737.0	177.1	1281.1
M36	36	55	3374.0	344.0	2488.5	3036.0	309.6	2239.2

Table 5. Metric Grade 12.9 Fasteners

Bolt Size		Hexagon (A/F)	Condition 1			Condition 2		
ISO Metric Thread	mm	mm	Nm	kgf m	lbf ft	Nm	kgf m	lbf ft
M5	5	8	9.8	1.0	7.2	8.8	0.9	6.5
M6	6	10	16.6	1.7	12.2	15.0	1.5	11.1
M8	8	13	40.0	4.1	29.5	36.0	3.7	26.5
M10	10	17	80.0	8.1	59.0	72.0	7.3	53.1
M12	12	19	139.0	14.2	102.5	125.0	12.7	92.2
M16	16	24	345.0	35.2	254.4	311.0	31.7	229.4
M20	20	30	674.0	68.7	497.1	607.0	61.9	447.7
M24	24	36	1165.0	118.8	859.2	1048.0	106.9	773.0
M30	30	46	2316.0	236.2	1708.2	2084.0	212.5	1537.1
M36	36	55	4049.0	412.9	2986.4	3644.0	371.6	2687.7



Section 1 - General Information Torque Settings

Zinc Plated Fasteners and Dacromet Fasteners

Table 6. Torque Settings - Rivet Nut Bolts/Screws

Bolt Size		Nm	kgf m	lbf ft
ISO Metric Thread	mm			
M3	3	1.2	0.1	0.9
M4	4	3.0	0.3	2.0
M5	5	6.0	0.6	4.5
M6	6	10.0	1.0	7.5
M8	8	24.0	2.5	18.0
M10	10	48.0	4.9	35.5
M12	12	82.0	8.4	60.5

Table 7. Torque Settings - Internal Hexagon Headed Cap Screws (Zinc)

Bolt Size		Nm	kgf m	lbf ft
ISO Metric Thread				
M3		2.0	0.2	1.5
M4		6.0	0.6	4.5
M5		11.0	1.1	8.0
M6		19.0	1.9	14.0
M8		46.0	4.7	34.0
M10		91.0	9.3	67.0
M12		159.0	16.2	117.0
M16		395.0	40.0	292.0
M18		550.0	56.0	406.0
M20		770.0	79.0	568.0
M24		1332.0	136.0	983.0

Hydraulic Connections

T11-003

'O' Ring Face Seal System

Adaptors Screwed into Valve Blocks

Adaptor screwed into valve blocks, seal onto an 'O' ring which is compressed into a 45° seat machined into the face of the tapped port.

Table 8. Torque Settings - BSP Adaptors

BSP Adaptor Size	Hexagon (A/F)	Nm	kgf m	lbf ft
	in.			
1/4	19.0	18.0	1.8	13.0
3/8	22.0	31.0	3.2	23.0
1/2	27.0	49.0	5.0	36.0
5/8	30.0	60.0	6.1	44.0
3/4	32.0	81.0	8.2	60.0
1	38.0	129.0	13.1	95.0
1 1/4	50.0	206.0	21.0	152.0

Table 9. Torque Settings - SAE Connections

SAE Tube Size	SAE Port Thread Size	Hexagon (A/F)	Nm	kgf m	lbf ft
		mm			
4	7/16 - 20	15.9	20.0 - 28.0	2.0 - 2.8	16.5 - 18.5
6	9/16 - 18	19.1	46.0 - 54.0	4.7 - 5.5	34.0 - 40.0
8	3/4 - 16	22.2	95.0 - 105.0	9.7 - 10.7	69.0 - 77.0
10	7/8 - 14	27.0	130.0 - 140.0	13.2 - 14.3	96.0 - 104.0
12	1 1/16 - 12	31.8	190.0 - 210.0	19.4 - 21.4	141.0 - 155.0
16	1 5/16 - 12	38.1	290.0 - 310.0	29.6 - 31.6	216.0 - 230.0
20	1 5/8	47.6	280.0 - 380.0	28.5 - 38.7	210.0 - 280.0

Buy Now



Our support email:

ebooklibonline@outlook.com