

**INDUSTRIAL
DIESEL ENGINE**

**4HK1 - 6HK1
MODEL**

WORKSHOP MANUAL

ISUZU MOTORS LIMITED

ENGINE

ENGINE MECHANICAL (4HK1, 6HK1)

TABLE OF CONTENTS

ISUZU DIESEL ENGINE (4HK1, 6HK1)	1A-3	Inspection	1A-81
Precautions on Service Work	1A-3	Reassembly	1A-87
Main Data and Specifications	1A-11	Installation	1A-93
Cylinder Head Cover	1A-14	Torque Specifications	1A-100
Components	1A-14	Special Tool	1A-100
Removal	1A-15	Piston, Connecting Rod	1A-102
Installation	1A-16	Components	1A-102
Torque Specifications	1A-18	Removal	1A-102
Inlet Cover	1A-20	Disassembly	1A-103
Components	1A-20	Reassembly	1A-109
Removal	1A-21	Installation	1A-111
Installation	1A-22	Torque Specifications	1A-113
Torque Specifications	1A-24	Special Tool	1A-113
Turbocharger and Exhaust Manifold	1A-25	Flywheel	1A-114
Components	1A-25	Components	1A-114
Removal	1A-26	Removal	1A-114
Inspection	1A-27	Inspection	1A-116
Installation	1A-28	Installation	1A-116
Torque Specifications	1A-32	Torque Specifications	1A-118
Timing Gear Train	1A-35	Special Tool	1A-118
Components	1A-35	Front Cover	1A-119
Removal	1A-36	Components	1A-119
Inspection	1A-38	Removal	1A-120
Installation	1A-40	Installation	1A-121
Torque Specifications	1A-51	Torque Specifications	1A-123
Special Tool	1A-52	Crankshaft Front Oil Seal	1A-125
Rocker Arm Shaft ASM	1A-53	Components	1A-125
Components	1A-53	Removal	1A-125
Removal	1A-53	Installation	1A-127
Disassembly	1A-54	Torque Specifications	1A-132
Reassembly	1A-56	Special Tool	1A-132
Installation	1A-57	Crankshaft Rear Oil Seal	1A-133
Torque Specifications	1A-58	Components	1A-133
Camshaft ASM	1A-59	Removal	1A-133
Components	1A-59	Installation	1A-134
Removal	1A-60	Special Tool	1A-137
Disassembly	1A-61	Crankshaft	1A-138
Reassembly	1A-63	Components	1A-138
Fixing torque	1A-65	Removal	1A-138
Special Tool	1A-65	Disassembly	1A-140
Installation	1A-66	Reassembly	1A-140
Torque Specifications	1A-68	Inspection	1A-140
Valve Stem Seal, Valve Spring	1A-69	Installation	1A-145
Components	1A-69	Torque Specifications	1A-149
Removal	1A-69	Special Tool	1A-149
Inspection	1A-70	Cylinder Block	1A-151
Installation	1A-71	Components	1A-151
Special Tool	1A-73	Removal	1A-151
Cylinder Head	1A-74	Inspection	1A-152
Components	1A-74	Installation	1A-153
Removal	1A-74	Lubrication System	1A-156
Disassembly	1A-78	Precautions on Service Work	1A-156

1A-2 ENGINE MECHANICAL (4HK1, 6HK1)

Function Check	1A-157
Special Tool	1A-158
Oil Port Cover ASM.....	1A-159
Components.....	1A-159
Removal.....	1A-159
Installation	1A-159
Oil Cooler	1A-161
Components.....	1A-161
Removal.....	1A-162
Disassembly.....	1A-163
Reassembly.....	1A-163
Installation	1A-164
Oil Pan	1A-167
Components.....	1A-167
Removal.....	1A-167
Installation	1A-167
Oil Pump	1A-170
Components.....	1A-170
Removal.....	1A-170
Disassembly.....	1A-171
Reassembly.....	1A-171
Inspection.....	1A-172
Installation	1A-173
Oil Pressure Switch.....	1A-177
Inspection.....	1A-177

ISUZU DIESEL ENGINE (4HK1, 6HK1)

Precautions on Service Work

Matters that require attention in terms of maintenance

To prevent damage to the engine and ensure reliability of its performance, pay attention to the following in maintaining the engine: When taking down the engine on the ground, do not make the bearing surface of the oil pan touch directly the ground. Use a wood frame, for example, to support the engine with the engine foot and the flywheel housing.

Because there is only a small clearance between the oil pan and the oil pump strainer, it can damage the oil pan and the oil strainer.

- When the air duct or air cleaner is removed, cover the air intake opening to prevent foreign matter from getting into the cylinder. If it gets into it, it can considerably damage the cylinder and others while the engine is operating.
- When maintaining the engine, never fail to remove the battery ground cable. If not, it may damage the wire harness or electrical parts. If you need electricity on for the purpose of inspection, for instance, watch out for short circuits and others.
- Apply engine oil to the sliding contact surfaces of the engine before reassembling it. This ensures adequate lubrication when the engine is first started.
- When valve train parts, pistons, piston rings, connecting rods, connecting rod bearings or crankshaft journal bearings are removed, put them in order and keep them.
- When installing them, put them back to the same location as they were removed.
- Gaskets, oil seals, O-rings, etc. must be replaced with new ones when the engine is reassembled.
- As for parts where a liquid gasket is used, remove an old liquid gasket completely and clean it up thoroughly so that no oil, water or dust may be clung to them. Then, apply the designated liquid gasket to each place anew before assembly.
- Surfaces covered with liquid gasket must be assembled within 7 minutes of gasket application. If more than 7 minutes have elapsed, remove the existing liquid gasket and apply new liquid gasket.
- When assembling or installing parts, fasten them with the specified tightening torque so that they may be installed properly.

Matters that require attention in specifically dealing with this engine.

Holes or clearances in the fuel system, which serve as a passage of fuel, including the inside of the injector, are made with extreme precision. For this reason, they are highly sensitive to foreign matter and if it gets in, it can lead to an accident on the road, for instance; thus, make sure that foreign matter will be prevented from getting in.

When servicing the fuel system, every precaution must be taken to prevent the entry of foreign material into the system.

- Before beginning the service procedure, wash the fuel line and the surrounding area.
- Perform the service procedures with clean hands. Do not wear work gloves.
- Immediately after removing the fuel hose and/or fuel pipe, carefully tape vinyl bags over the exposed ends of the hose or pipe.
- If parts are to be replaced (fuel hose, fuel pipe, etc.) do not open the new part packaging until installation.

Work procedure

- The fuel opening must be quickly sealed when removing the fuel pipe, injection pipe, fuel injector, fuel supply pump, and common rail.
- The eyebolts and gasket must be stored in a clean parts box with a lid to prevent adhesion of foreign matter.
- Fuel leakage could cause fires. Therefore, after finishing the work, wipe off the fuel that has leaked out and make sure there is no fuel leakage after starting the engine.

1A-4 ENGINE MECHANICAL (4HK1, 6HK1)

How to read the model

4HK1

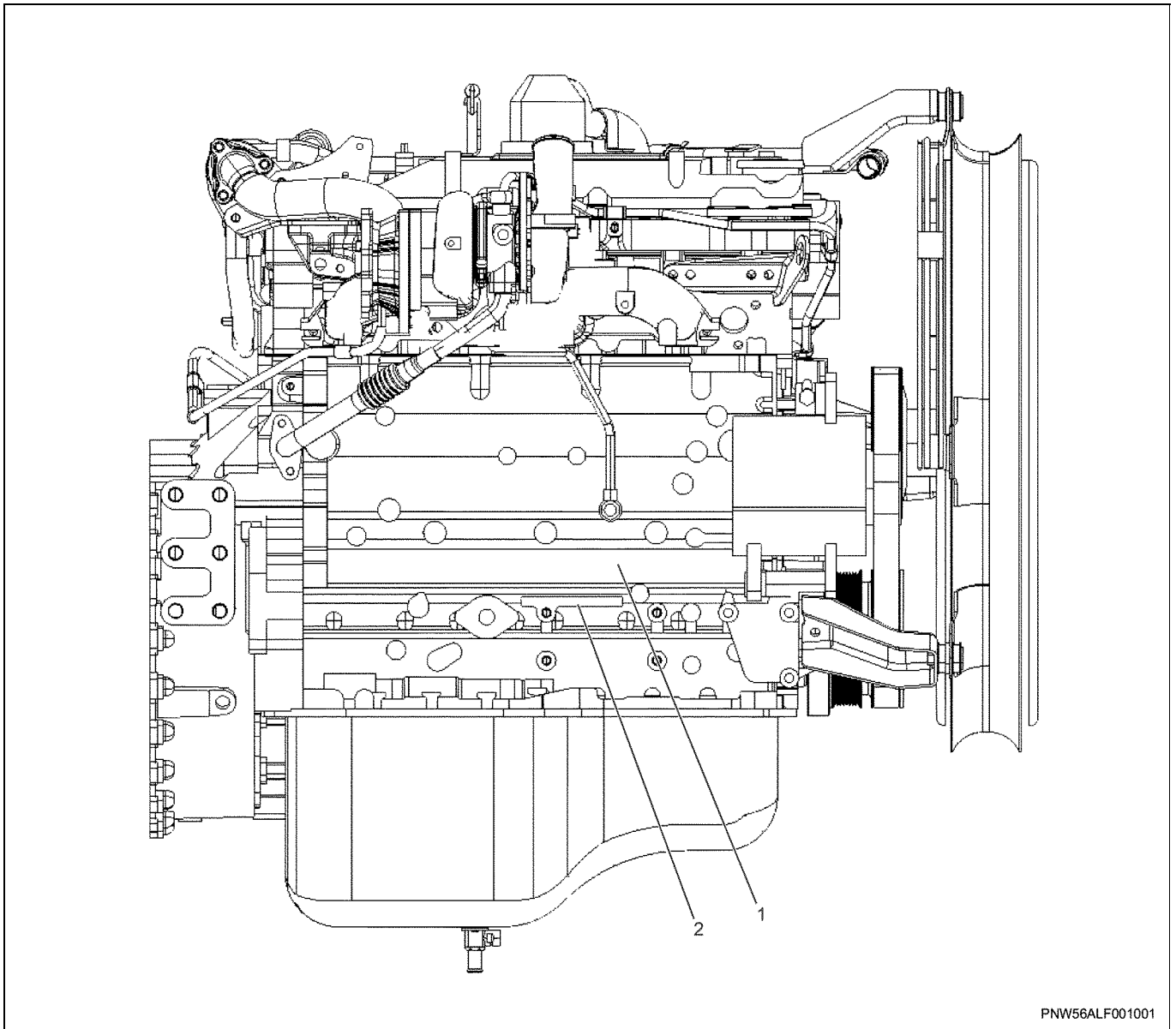

PNW56ALF001001

Name

1. Cast The Engine Model

2. Stamp An Engine Number

6HK1

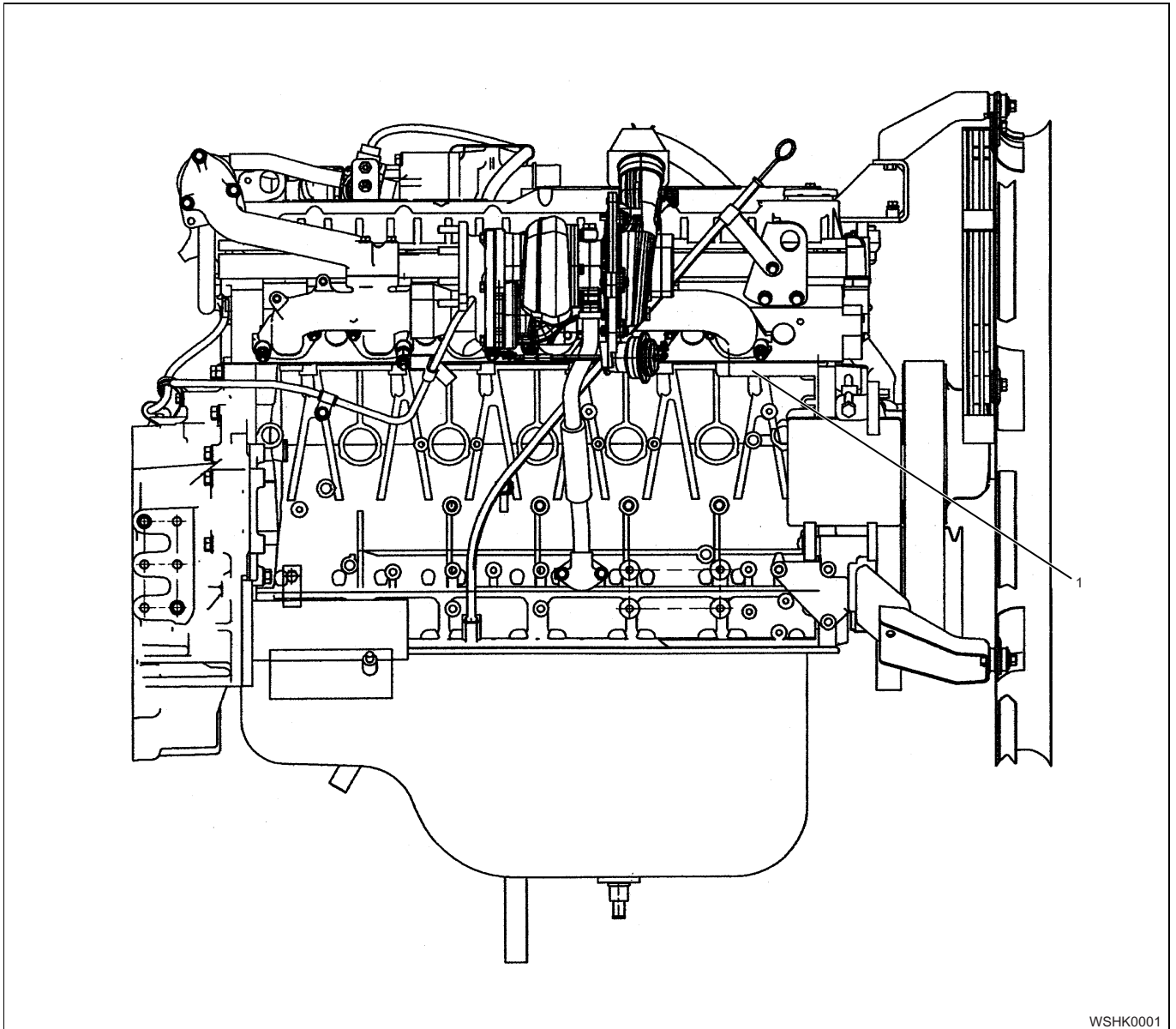

WSHK0001

Name

1. Stamp An Engine Number

Explanations on functions and operation**Electronic engine control**

With the control unit, the range from injection to air intake/exhaust, including fuel injection quantity, injection timing, intake air restriction, EGR, and idling rpm, is controlled.

Cylinder block

The cylinder block is cast-iron with the center distance of each bore being equal and is of the highly rigid, symmetrical structure with the crankshaft center being the center. The bearing cap is of the ladder frame structure and tightened up under the plastic range rotation angle method.

Cylinder liner

The cylinder liner is selected to match an internal diameter of a bore of the cylinder block and built, which is imprinted on the left side of the cylinder.

Piston

The piston is aluminum-alloy and an autothermatic piston with a strut cast, while the combustion chamber is a round reentrant type.

Cylinder head

The cylinder head is cast-iron and there are 4 valves per cylinder. The angular tightening method of the cylinder head bolt further increases reliability and durability.

1A-6 ENGINE MECHANICAL (4HK1, 6HK1)

Crankshaft

Tuffriding is given, while on the No. 1 balance weight imprinted is the grade of each journal diameter.

EGR system

Based upon data, including water temperature, engine speeds or engine loads, it is controlled via Engine Control Module (ECM) to purify exhaust by recycling part of it.

Its main components include an EGR valve, an EGR cooler and various sensors.

Connecting rod cap bolt

The angular tightening method of the connecting rod cap bolt further increases reliability and durability.

Common rail-type electronic control injection system

The common rail-type electronic control injection system is composed of a fuel supply pump that sets the target pressure of high-pressure fuel and supply it, a common rail that measures such high-pressure fuel and a fuel injector that turns it into a fine spray and injects it. Each is controlled via ECM based upon various signals, while injection timing or fuel injection quantity is controlled under every possible driving condition.

Fuel injector

The fuel injector is a 7-hole nozzle that adjusts fuel injection quantity or injection timing by opening or closing an electromagnetic valve on the head of the fuel injector.

ECM corrects the dispersion of fuel injection quantity between fuel injectors according to ID code data in memory. At the replacement of fuel injectors, ID code data should be stored in ECM.

Fuel filter with sedimenter

It is a fuel filter with sedimenter that gets rid of water by making use of the difference in specific gravity between light oil and water, which comes with an indicator that notifies you that it is filled with water.

Preheating system

The preheating system consists the ECM, the glow relay, glow plugs and the glow indicator lamp. The preheating system is operated when the engine coolant temperature is low, and make the engine easy to start.

Lubrication system

It is an oil filter with full-flow bypass, which uses a water-cool oil cooler and oil jet to cool the piston.

Function check

Inspection/adjustment of valve clearance

1. Inspection of valve clearance
 - Remove the cylinder head cover.
 - Remove the fuel injector harness ASM.
 - Loosen the terminal nuts alternately to remove.
 - Remove the leak off pipe.

- Rotate the crankshaft to make the No.1 cylinder meet the compression top dead center (TDC).

4HK1

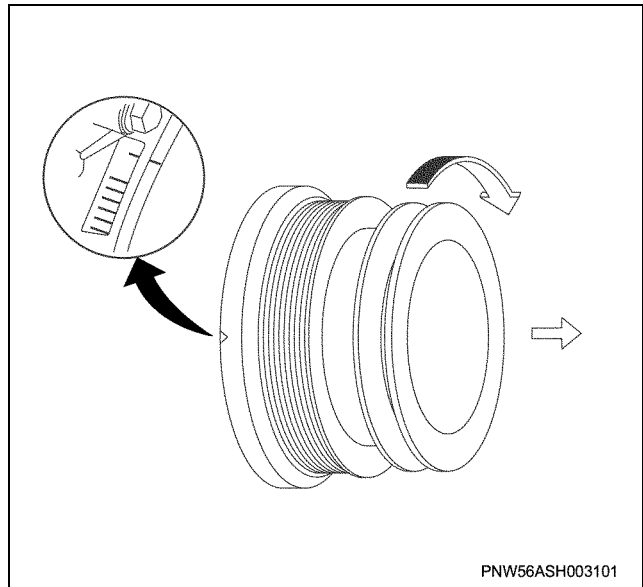

6HK1

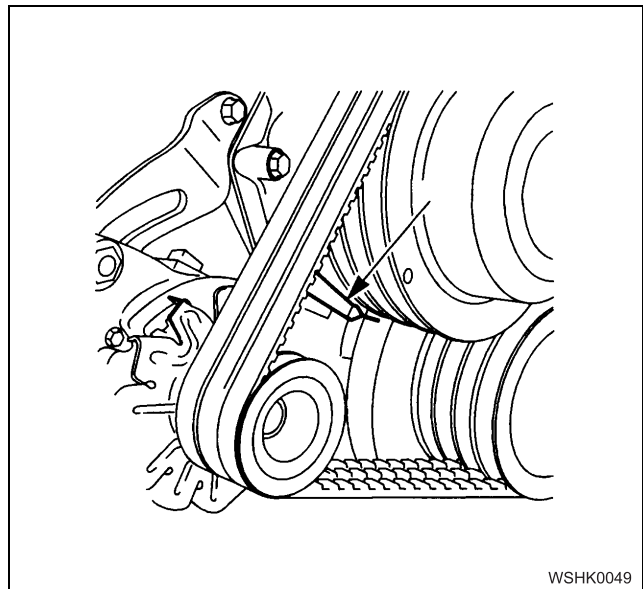

- Insert a 0.4 mm thickness gauge into a clearance between the rocker arm and the bridge to check it and adjust it if needed.

Valve clearance	mm (in)
Intake valve	0.4 (0.016)
Exhaust valve	0.4 (0.016)

Caution:

Adjust while being cold.

2. Adjustment of valve clearance

Caution:

Adjust valve clearance carefully so that the bridge may become level (hit the end of the 2 valve axes).

- a. Completely loosen all of the bridge and rocker arm adjusting nuts and adjusting screws (4HK1: 8 nuts and 8 screws, 6HK1: 12 nuts and 12 screws).
- b. Place a 0.4 mm thickness gauge between the No. 1 cylinder rocker arm end and the bridge cap.
- c. Tighten the rocker arm adjusting screw until the thickness gauge is snug (not tight) between the rocker arm end and the bridge cap.
- d. Tighten the rocker arm lock nut.
- e. Tighten the bridge adjusting screw until the bridge contacts the valve head.
- f. Tighten the bridge lock nut.
- g. Check that the thickness gauge is still held snugly between the rocker arm end and the bridge cap. If it is too tight, slightly loosen the bridge adjusting screw and lock nut to restore snugness.
- h. Remove the thickness gauge.
- i. Repeat Steps 2 through 5 for the remaining cylinders.

Tightening torque: 22 N·m (16 lb ft)

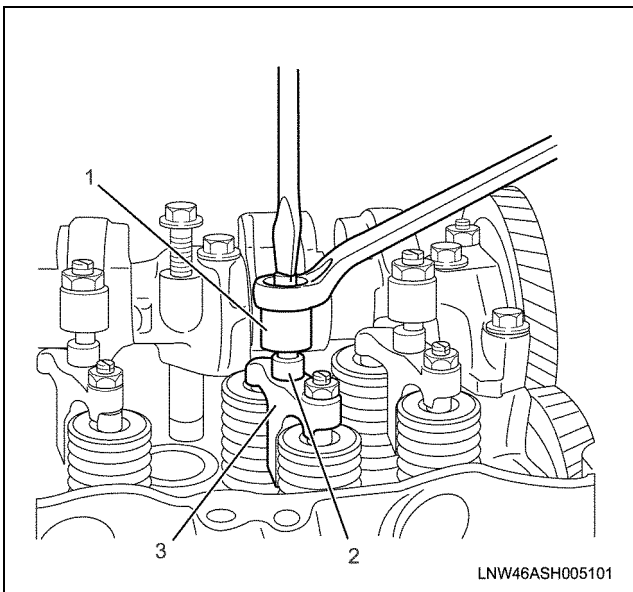

Name

1. Rocker Arm
2. Bridge Cap
3. Bridge

- With a thickness gauge kept inserted, tighten an adjusting screw of the bridge lightly and make sure that the tip of the adjusting screw touches the end of valve axis and the movement of the thickness gauge has become tight.
- Then, check if the end of the valve axis on the opposite side is unstable or hits diagonally. If so, loosen the bridge adjusting screw a little so that the end of the valves on both sides may touch properly.
Valve bridge clearance: ± 0.1 mm (0.0039 in) or less
- After making an adjustment so that the end of the valves on both sides may touch properly, tighten up an adjusting screw nut of the bridge with a flathead screwdriver so that the bridge adjusting screw may not rotate.

Tightening torque: 22 N·m (16 lb ft)

Caution:

If the adjusting screw of the bridge is poorly adjusted, the bridge would tilt and be pushed down and seized, which may damage the bridge guide, for example. Thus, adjust it accurately.

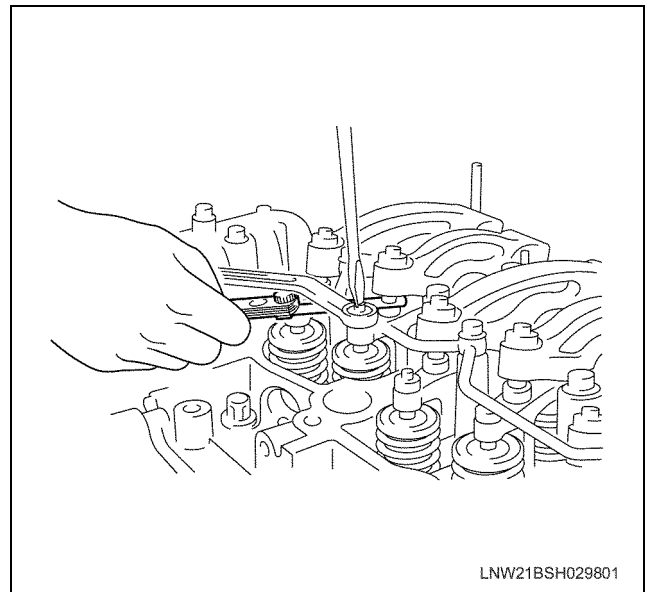

Tightening torque:

- | | |
|-----------------------------|-------------------|
| Rocker arm adjustment screw | 22 N·m (16 lb ft) |
| nut | |
| Bridge adjustment screw nut | 22 N·m (16 lb ft) |

1A-8 ENGINE MECHANICAL (4HK1, 6HK1)

Adjustment table (4HK1)

Cylinder No.	1		2		3		4	
	IN	EX	IN	EX	IN	EX	IN	EX
No. 1 cylinder Compression top dead center position	○	○	○			○		
No. 4 cylinder Compression top dead center position				×	×		×	×

Adjustment table (6HK1)

Cylinder No.	1		2		3		4		5		6	
	IN	EX	IN	EX	IN	EX	IN	EX	IN	EX	IN	EX
No. 1 cylinder Compression top dead center position	○	○	○			○	○			○		
No. 6 cylinder Compression top dead center position				×	×			×	×		×	×

- If the No. 1 cylinder is the compression TDC, adjust a valve clearance with ○ mark given on the table and if the No. 4 (4HK1) or No. 6 (6HK1) cylinder is the compression TDC, that with × mark.

4HK1

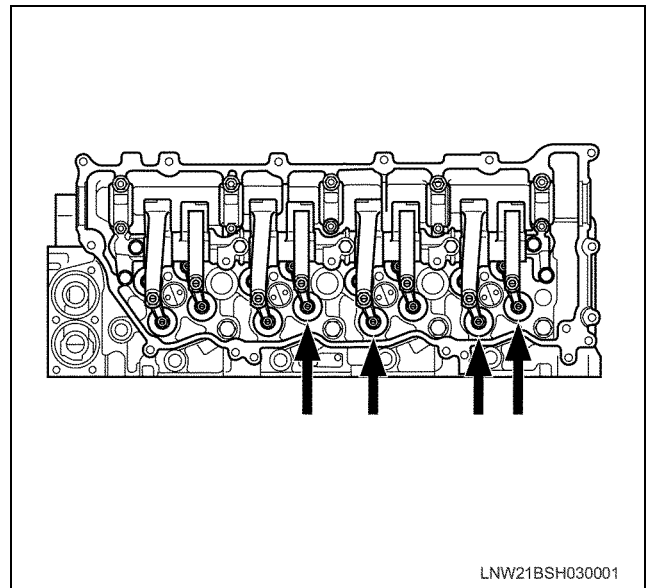
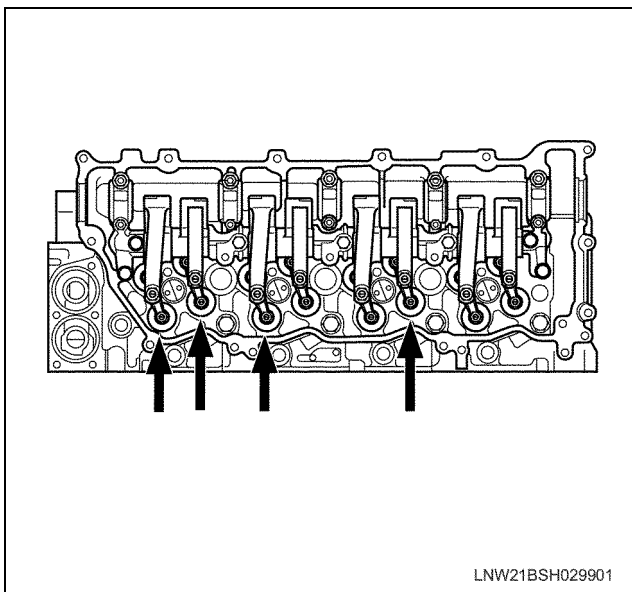

6HK1

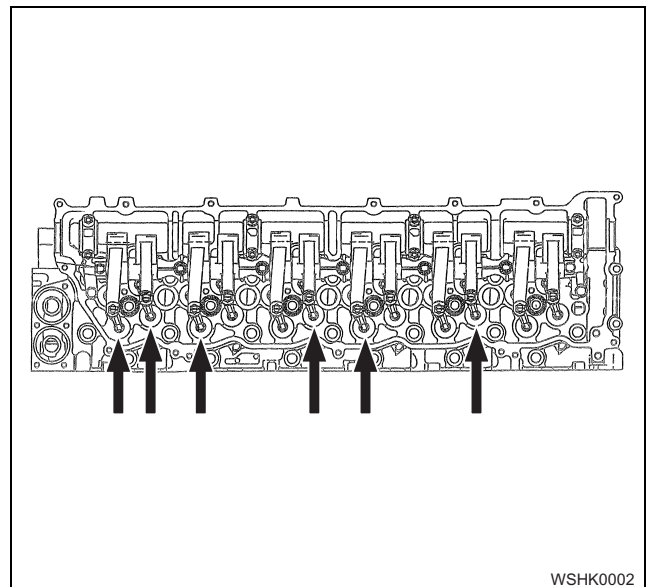

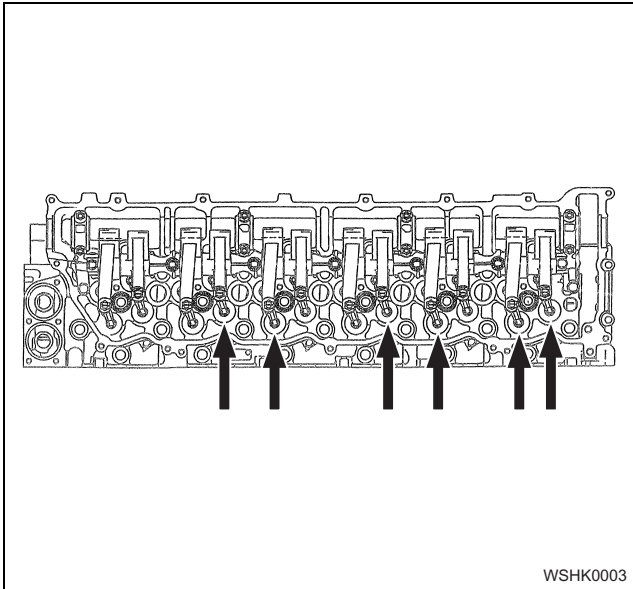

- Attach the harness ASM to the fuel injector. Tighten the harness bracket with the designated torque.

Tightening torque: 48 N·m (35 lb ft)

- Install the terminal nuts on the fuel injector.

Tightening torque: 2 N·m (17 lb ft)

Note:

- Tighten the terminal nuts alternately in order to prevent imbalance in tightening because they are unified.
- Do not tighten the nuts too tightly because it leads to damage to the terminal stud.
 - Install the cylinder head cover. Refer to the "Cylinder Head Cover".

Compression pressure inspection

- Warm-up the engine.
- Remove a negative terminal of the battery and remove all the glow plugs.
- Remove the harness connector for the fuel injector built on the lower head cover (no fuel will be injected).

Caution:

When the harness connector is removed, ECM judges that it broke down and DTC is recorded. Upon completion of measurement, never fail to clear memory of ECM.
(For how to clear memory of ECM, refer to the Engine Control System Section)

4HK1

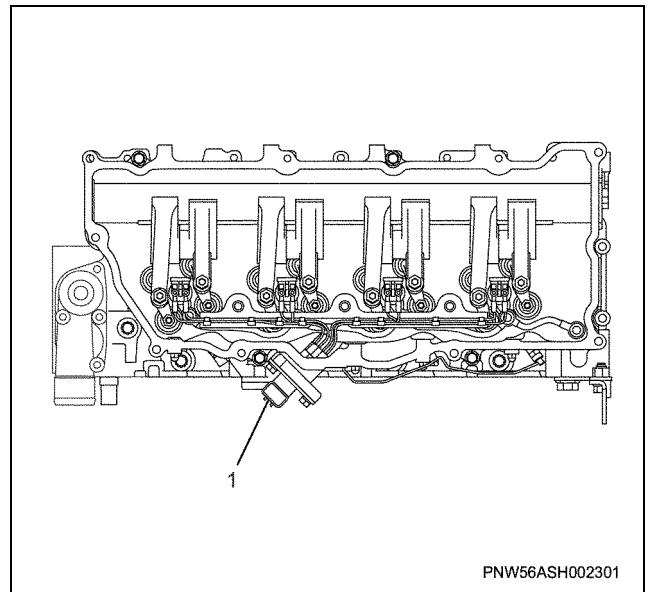

Name

1. Fuel Injector Harness Connector

6HK1

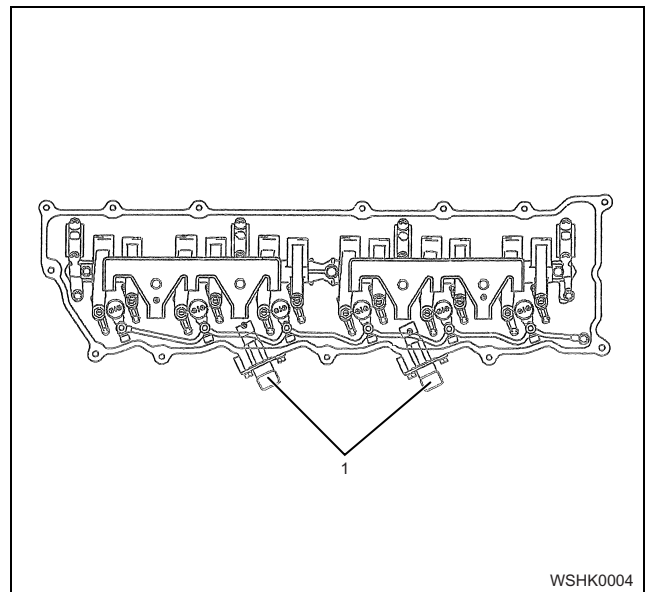

Name

1. Fuel Injection Harness Connector

- Install the negative terminal of the battery.
- Turn on the starter to emit foreign matter within the cylinders.
- Install an adapter and a gauge of a compression gauge of the special tool.

1A-10 ENGINE MECHANICAL (4HK1, 6HK1)

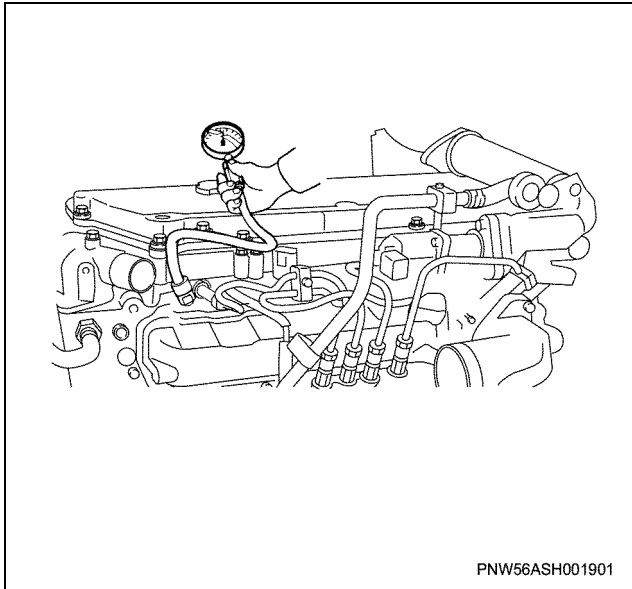

Compression gauge: 5-8840-2675-0 (J-26999-12)

Compression gauge adapter

4HK1: EN-46722

6HK1: 5-8840-2622-0

- Turn on the starter to inspect compression pressure.

4HK1

Compression pressure	MPa (psi) / 200 rpm
Standard	2.84 – 3.24 (412 – 469)
Limit	1.96 (284)
Differences among the cylinders	294 kPa (43)

6HK1

Compression pressure	MPa (psi) / 200 rpm
Standard	3.24 (469)
Limit	2.26 (327)
Differences among the cylinders	294 kPa (43)

- Measure each cylinder one by one.

Caution:

To keep engine speed at 200 rpm or more, use fully charged batteries.

- Remove a compression gauge of the special tool.
- Remove a negative terminal of the batteries.
- Install a harness connector for the fuel injector built on the lower head cover.
- Install all the glow plugs.

Tightening torque: 20 N·m (15 lb ft)

- Install the negative terminal of the battery.

Main Data and Specifications

Item		Engine model 4HK1
Type		Diesel/4-cycle/water cooled-type, inline four-cylinder OHC
Combustion chamber form		Direct injection type
Cylinder liner type		Dry type
Number of cylinders - cylinder bore × strokes	mm (in)	4-115 (4.53) × 125 (4.92)
Displacement	cc (cu.in)	5193 (317)
Compression ratio		17.5
Compression pressure	MPa (psi)/rpm	3.23 (468)/200
Idle speed	rpm	800
Valve clearance	Intake	0.4 (0.016) (cold)
	Exhaust	0.4 (0.016) (cold)
Ignition type		Compressed ignition
Injection order		1 - 3 - 4 - 2
Lubricating system		
Lubricating type		Pressure type
Oil pump type		Gear type
Volume of lubricating oil	L (qts)	13.0 (13.7) — 20.5 (21.7)
Oil filter type		Full flow filter (cartridge type)
Oil cooling type		Built-in, water-cooling
Cooling system		
Cooling type		Water cooling type
Radiator type		Corrugated fin (pressure type)
Water pump type		Centrifugal, belt type
Thermostat type		2 wax-type units
Thermostat valve-opening temperature	°C (°F)	85 (185)
Volume of coolant	L (qts)	14 (14.8) (incl. radiator)
Fuel system		
Injection pump type		Electronic control common rail type
Governor type		Electronic type
Timer type		Electronic type
Injection nozzle type		Multi-hole type 7-hole and ϕ 0.16 mm (0.0063 in) inside diameter
Charging system		
Generator type		AC type
Power output	V/A	24 - 50
Regulator type		IC



1A-12 ENGINE MECHANICAL (4HK1, 6HK1)

Item	Engine model 4HK1
Starting system	
Starter type	Reduction type
Power output	24 - 5.0
Preheat system type	Glow plug
Glow plug standard voltage/electric current	23 - 3.5

Item	Engine model 6HK1
Type	Diesel/4-cycle/water cooled-type, inline four-cylinder OHC
Combustion chamber form	Direct injection type
Cylinder liner type	Dry type
Number of cylinders - cylinder bore × strokes	6-115 (4.53) × 125 (4.92)
Displacement	7790 (475)
Compression ratio	17.5
Compression pressure	3.04 (441)/200
Idle speed	For Hitachi products: 800, For JCB and Sumitomo products: 900
Valve clearance	Intake
	Exhaust
	0.4 (0.016) (cold)
	0.4 (0.016) (cold)
Ignition type	Compressed ignition
Injection order	1 - 5 - 3 - 6 - 2 - 4
Lubricating system	
Lubricating type	Pressure type
Oil pump type	Gear type
Volume of lubricating oil	28 (29.6) — 38 (40.2)
Oil filter type	Full flow filter (cartridge type)
Oil cooling type	Built-in, water-cooling
Cooling system	
Cooling type	Water cooling type
Radiator type	Corrugated fin (pressure type)
Water pump type	Centrifugal, belt type
Thermostat type	2 wax-type units
Thermostat valve-opening temperature	82 (180)
Volume of coolant	14.5 (15.3)
Fuel system	
Injection pump type	Electronic control common rail type
Governor type	Electronic type
Timer type	Electronic type

Item	Engine model 6HK1
Injection nozzle type	Multi-hole type 7-hole and $\phi 0.16$ mm (0.0063 in) inside diameter
Charging system	
Generator type	AC type
Power output	24 - 120
Regulator type	IC
Starting system	
Starter type	Reduction type
Power output	24 - 5.0
Preheat system type	Glow plug
Glow plug standard voltage/electric current	23 - 3.5

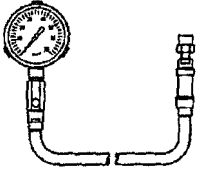
Special tool

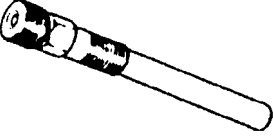
Illustration	Tool Number/Description
 <p>5884026750</p>	<p>5-8840-26750-0 J-26999-12 Compression gauge</p>
 <p>5884020080</p>	<p>EN-46722 Compression gauge adapter (4HK1)</p>
	<p>5-8840-2622-0 Compression gauge adapter (6HK1)</p>

Buy Now



Our support email:

ebooklibonline@outlook.com