



SINGLE DRUM ROLLER

SERVICE MANUAL SM95005

March 2003

Models 1105, 1106, 1405, 1805

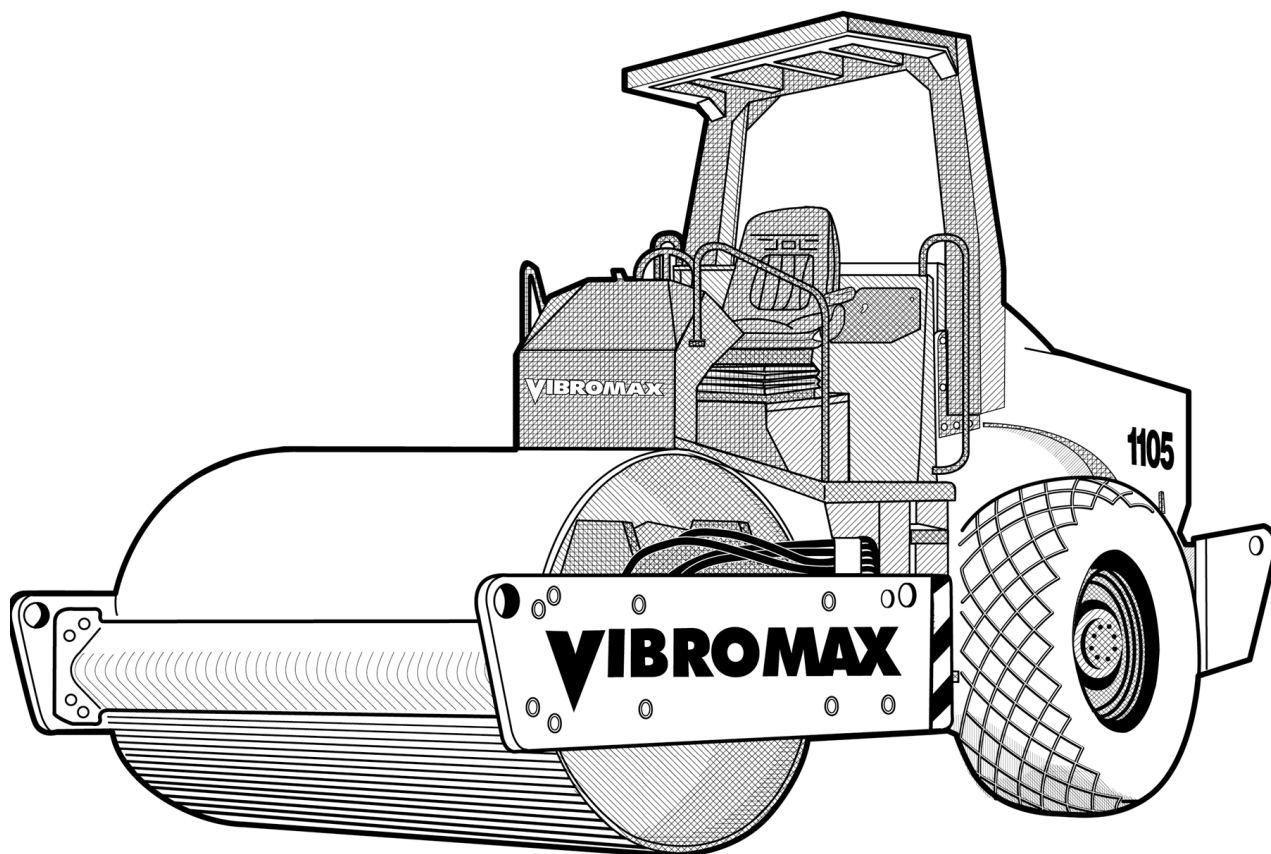

CALIFORNIA

Proposition 65 Warning

Diesel engine exhaust and some of its constituents are known to the State of California to cause cancer, birth defects, and other reproductive harm.

table of contents

SECTION ONE

GENERAL INFORMATION

MACHINE DESCRIPTION	1 - 3
SERIAL NUMBERS	1 - 5
IDENTIFYING MACHINE COMPONENTS	1 - 6
FLUID SPECIFICATIONS	1 - 7
MACHINE SPECIFICATIONS	1 - 8
Model 1105	1 - 9
Model 1106	1 - 11
Model 1405	1 - 13
Model 1805	1 - 15
STANDARD TORQUE DATA	1 - 16
DIESEL FUEL SPECIFICATION	1 - 18
ENGINE OIL SPECIFICATION	1 - 19
SAFETY, GENERAL	1 - 20
SPARK ARRESTER	1 - 20
SAFETY, PERSONAL	1 - 21
SAFETY, MACHINE OPERATION	1 - 22
SAFETY, MAINTENANCE	1 - 25
SAFETY, DECALS	1 - 27
HYDRAULIC HOOD OPERATION.....	1 - 30
HOOD INSTRUCTIONS	1 - 32

SECTION TWO

ENGINE

ENGINE DATA	2 - 2
CUMMINS ENGINE WARRANTY	2 - 3
ENGINE REMOVAL	2 - 4

table of contents

SECTION THREE

ELECTRICAL

GENERAL INFORMATION	3 - 2
FUSE LOCATION	3 - 3
RELAY LOCATION	3 - 3
INSTRUMENT PANEL	3 - 4
UNDERSTANDING ELECTRICAL SCHEMATICS	3 - 7
UNDERSTANDING RELAYS	3 - 9
VIBROMAX RELAYS	3 - 11
STARTER/CHARGING CIRCUIT (Cummins 6B5.9C)	3 - 13
STARTER/CHARGING CIRCUIT (Cummins 6BT5.9C)	3 - 15
UNDERSTANDING BATTERIES	3 - 15
BATTERY DIAGNOSTICS	3 - 16
UNDERSTANDING ALTERNATORS	3 - 17
CHARGING SYSTEM DIAGNOSTICS	3 - 18
VOLTAGE CHECKS AT ALTERNATOR	3 - 19
SYSTEM LEAKAGE	3 - 19
CIRCUIT WIRING TEST	3 - 19
MEASURING ALTERNATOR OUTPUT	3 - 20
UNDERSTANDING STARTERS	3 - 20
STARTER SOLENOID	3 - 21
STARTER SYSTEM DIAGNOSTICS	3 - 21
SOLENOID CIRCUIT TEST	3 - 21
STARTER CIRCUIT WIRING TEST	3 - 22
STARTER MOTOR TEST	3 - 23
INSTRUMENTATION PANEL	3 - 25
EMERGENCY STOP SWITCH/ BRAKE SWITCH	3 - 27
HIGH SPEED CIRCUIT	3 - 29
VIBRATION CIRCUIT	3 - 31
LIGHTING CIRCUIT	3 - 33
WORK LIGHTS, ACCESSORY PLUG, HEATER AND WIPERS	3 - 35
CAB WIRING	3 - 44
WIRE HARNESS 7241/80315 (0)	3 - 45
WIRE CHART 7241/80315 (0)	3 - 50
WIRE HARNESS 7241/80110(0)A	3 - 54
WIRE CHART 7241/80110(0)A	3 - 55
WIRE HARNESS 7241/80510(0)B	3 - 56
WIRE CHART 7241/80510(0)B	3 - 57

table of contents

SECTION FOUR

HYDRAULIC

PUMP SUCTION LINES	4 - 2
HYDRAULIC COOLING SYSTEM	4 - 4
HYDRAULIC DRAIN LINES	4 - 6
HYDRAULIC TEST SYSTEM	4 - 8
HYDRAULIC TEST STATION	4 - 9
CHARGE SYSTEM	4 - 11
PROPULSION SYSTEM	4 - 13
MULTIFUNCTION VALVES	4 - 17
PROPULSION SYSTEM DIAGNOSTICS	4 - 18
INTERNAL LEAKAGE	4 - 18
PUMP SERVO CONTROL	4 - 19
VIBRATION SYSTEM	4 - 21
VIBRATION FREQUENCY	4 - 23
VIBRATION AMPLITUDE.....	4 - 25
VIBRATORY SYSTEM DIAGNOSTICS	4 - 26
STEERING SYSTEM	4 - 27
PARKING BRAKE SYSTEM	4 - 30
TOWING YOUR MACHINE	4 - 31
TOWING PROCEDURE	4 - 32
PARKING BRAKE DIAGNOSTICS	4 - 32
DIFFERENTIAL LOCK SYSTEM	4 - 35
HOOD LIFT SYSTEM.....	4 - 38
HYDRAULIC COMPONENTS	4 - 40
HYDRAULIC SCHEMATIC	4 - 41

SECTION FIVE

POWER TRAIN

GENERAL INFORMATION	5 - 2
OPERATION	5 - 3
SPETH AXLE	5 - 4
REAR AXLE REMOVAL.....	5 - 5
REAR AXLE INSTALLATION.....	5 - 6
AXLE TUBE DISASSEMBLY	5 - 8
PLANETARY DISSASSEMBLY	5 - 10
DIFFERENTIAL LOCK REMOVAL	5 - 12
DIFFERENTIAL LOCK ASSEMBLY	5 - 13

table of contents

AXLE TUBE AND PLANETARY ASSEMBLY	5 - 14
INTERMEDIATE GEARBOX DISASSEMBLY	5 - 18
INTERMEDIATE GEARBOX ASSEMBLY	5 - 20
DIFFERENTIAL DISASSEMBLY	5 - 22
DIFFERENTIAL ASSEMBLY	5 - 24
DRUM REMOVAL	5 - 29
DRUM INSTALLATION	5 - 29
DRUM DRIVE	5 - 30
DRUM DRIVE BEARING REMOVAL	5 - 32
DRUM DRIVE BEARING INSTALLATION	5 - 34
DRUM DRIVE MOTOR REPAIRS	5 - 36
DRUM DRIVE GEARBOX	5 - 36
GFT 17 T2/312 2 GEARBOX	5 - 38
GFT 36 T3 1042 GEARBOX	5 - 40

SECTION SIX

PARKING BRAKE SYSTEM

DESCRIPTION	6 - 2
BRAKE RELEASE AND TOWING	6 - 4
TOWING PROCEDURE	6 - 5
AXLE BRAKE	6 - 6
AXLE BRAKE PARTS LIST	6 - 8

SECTION SEVEN

VIBRATION SYSTEM

VIBRATION SYSTEM	7 - 2
VIBRATION FREQUENCY	7 - 3
VIBRATION AMPLITUDE	7 - 5
VIBRATORY SYSTEM DIAGNOSTICS	7 - 6
LIFTING DEVICE	7 - 7
DRUM REMOVAL	7 - 8
DRUM INSTALLATION	7 - 8
EXCITER BEARING REMOVAL	7 - 9
EXCITER BEARING ASSEMBLY	7 - 13
DRUM EXCITER SHAFT	7 - 14

table of contents

SECTION EIGHT

STEERING SYSTEM

SPECIAL TOOLS 8 - 2
ARTICULATION JOINTS 8 - 3
JOINT DISASSEMBLY 8 - 5
JOINT ASSEMBLY 8 - 9
STEERING CYLINDER 8 - 12

SECTION NINE

CHASSIS

DRUM FRAME 9 - 2
REAR FRAME 9 - 3
HOOD 9 - 4
OPERATOR PLATFORM 9 - 5
ROLLOVER PROTECTION STRUCTURE 9 - 6

SECTION TEN

ATTACHMENTS

LEVELING BLADE 10 - 2
BLADE CONTROL 10 - 3
BLADE HYDRAULIC LINES 10 - 4

SECTION ONE

GENERAL INFORMATION

MACHINE DESCRIPTION

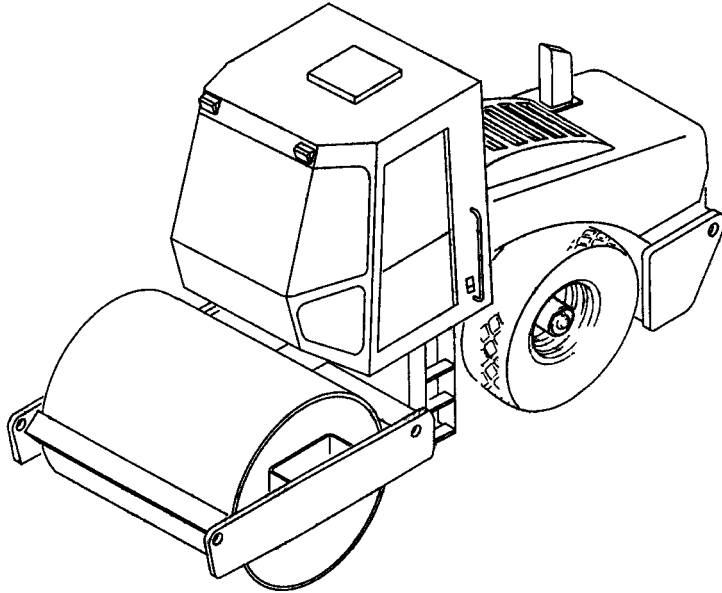

In the fall of 1998 Vibromax introduced a new series of heavy single drum vibratory rollers. Included in the new series are the models 1105, 1106, 1405, and 1805.

The new rollers all use the Cummins 5.9 liter 6 cylinder engine. Some engines are turbocharged and after cooled depending on the machine model. All of the new engines are tuned to meet the latest EPA emissions standards.

A Sauer Sundstrand Series 90 variable displacement, axial piston hydrostatic pump, used for machine propulsion, is mounted to the flywheel end of the engine. It provides oil to a Rexroth 2 speed drum drive motor and a 2 speed axle drive motor in a parallel path. The Rexroth motor is mounted on the left side of the drum and drives through a planetary gearbox and is isolated from the drum by rubber buffers. The axle drive motor is attached directly to the intermediate gearbox on the rear axle.

The vibration system uses a Sauer Sundstrand Series 90 hydrostatic pump similar to the propulsion pump and mounted directly behind the propulsion pump. The vibratory pump supplies oil to a Series 90 hydrostatic motor mounted at the right side of the drum. The new models operate at frequencies of 1740 or 2160 vibrations per minute on both the smooth drum and pad foot versions.

Buy Now



Our support email:

ebooklibonline@outlook.com